

CTI 2500 Series[®]
REMOTE I/O SYSTEM
DESIGN, INSTALLATION
& TROUBLESHOOTING GUIDE

Version 1.3

**Copyright© 2013 Control Technology Inc.
All rights reserved.**

This manual is published by Control Technology Inc. (CTI) 5734 Middlebrook Pike, Knoxville, TN 37921. This manual contains references to brand and product names which are tradenames, trademarks, and/or registered trademarks of Control Technology Inc. Siemens®, SIMATIC®, and Series 505®, and 505® are registered trademarks of Siemens AG. Other references to brand and product names are tradenames, trademarks, and/or registered trademarks of their respective holders.

DOCUMENT DISCLAIMER STATEMENT

Every effort has been made to ensure the accuracy of this document; however, errors do occasionally occur. CTI provides this document on an “as is” basis and assumes no responsibility for direct or consequential damages resulting from the use of this document. This document is provided without express or implied warranty of any kind, including but not limited to the warranties of merchantability or fitness for a particular purpose. This document and the products it references are subject to change without notice. If you have a comment or discover an error, please call us toll-free at 1-800-537-8398 or email us at sales@controltechnology.com.

REVISION HISTORY		
V1.0	08OCT2008	Initial Release
V1.1	03MAY2013	Added note about Belden cable compatibility
V1.2	11JLY2013	Added section on redundant topology, Add manual links to new Website, Replace RIO-A references with RIO-B
V1.3	17SEP2013	Added alternate redundant topology and new Belden cable spec

PREFACE

This ***Remote I/O System Design & Troubleshooting Guide*** provides reference information for constructing and operating CTI 2500 Series® Remote I/O networks. The information in this manual is directed to individuals who will be installing and operating the processor as well as those who will be designing systems that use it.

For comprehensive processor information, you should also obtain the *CTI 2500 Installation and Operation Guide* (CTI Part # 062 -00370-010).

USAGE CONVENTIONS

NOTE:

Notes alert the user to special features or procedures.

CAUTION:

Cautions alert the user to procedures that could damage equipment.

WARNING:

Warnings alert the user to procedures that could damage equipment and endanger the user.

TABLE OF CONTENTS

CHAPTER 1	OVERVIEW.....	1
1.1	Introduction.....	1
1.2	Network Features.....	1
1.2.1	Electrical Interface	1
1.2.2	I/O Protocol	1
1.2.3	Compatibility	1
1.3	System Components.....	1
1.3.1	2500 Series® Processor	2
1.3.2	2500 Series® Remote Base Controller	2
1.3.3	Network Cabling & Taps	3
1.3.4	Network Terminations	3
CHAPTER 2	DESIGN & INSTALLATION.....	5
2.1	Plan and Specify I/O Network Requirements.....	5
2.2	Specify and design the network topology.....	5
2.2.1	Select Basic Network Topology	5
2.2.2	Placing Taps and Designing Droplines	7
2.2.3	Dual Media and Hardware Redundancy Installations	8
2.3	Specify cable type.....	10
2.4	Specify terminations.....	10
2.5	Document the I/O network.....	11
2.6	Construct the I/O network.....	11
2.6.1	General Cabling Guidelines	11
2.6.2	Constructing Trunk Line Cables	12
2.6.3	Connecting Trunk Lines to Taps	13
2.6.4	Constructing Drop Line Cables	14
2.6.5	Connecting Drop Lines to Taps	14
2.6.6	Attach D-connector to Drop Line for Connection to 2500 Series® Processor or RBC	15
2.7	Commission the I/O network.....	15
CHAPTER 3	SYSTEM CONFIGURATION.....	19
3.1	Configuring the 2500 Series® Processor.....	19
3.1.1	Setting the Enable/Disable status of each base	19
3.1.2	Set Slot Configuration and Starting I/O Address	21
3.2	Configuring the 2500-RIO Remote Base Controller.....	22
3.2.1	Setting the RS232 Port Baud Rate	22
3.2.2	Setting Remote Base Controller Station Address	22
3.2.3	Setting the Output State on Communication Loss	23
CHAPTER 4	TROUBLESHOOTING.....	25
4.1	Commissioning instructions.....	25
4.2	RBC setup and status indicators.....	25
4.3	I/O status configuration and status screens in WorkShop.....	26
4.4	System status words.....	26
4.5	Fatal and Non-Fatal Error Codes.....	26

CHAPTER 1 OVERVIEW

1.1 Introduction

The CTI 2500 Series® Remote I/O System provides I/O networking of up to 15 remote bases to 2500 Series® Processors.

The system employs a standard RS-485 electrical interface and a specialized communications protocol to communicate with the remote bases and operate process I/O. Error detection, correction, and recovery is automatically handled, eliminating any need to these operations in the user program.

Two 2500-RIO-B base controllers can be installed as a pair in a redundant base (2500-R11-A) in order to have dual media and hardware redundancy.

1.2 Network Features

1.2.1 Electrical Interface

The electrical interface is standard RS-485, differential signaling, unbiased. This standards-based approach allows many choices for selection of cabling and other network components.

1.2.2 I/O Protocol

The I/O protocol uses Miller Encoding to minimize signal bandwidth required and maximize reliability.

1.2.3 Compatibility

The CTI 2500 Series® Remote I/O System is compatible with Simatic® 505 remote I/O components. Users can freely combine Processors and Remote Base Controllers (RBCs) from both CTI and Siemens® on the same network.

1.3 System Components

The following components are required to make an operating 2500 Series® Remote I/O system:

- 2500 Series® Processor support Remote I/O
- One or more 2500 Series® Remote Base Controllers (RBCs)
- Network cabling and taps
- Network connectors
- Network terminations



1.3.1 2500 Series® Processor

The CTI 2500 Series® Processor is available in four models. All models except the 2500-C100 support operation of a remote I/O network.

2500 Series™ PLC System Product Bulletin

CTI 2500 Series™ Programmable Controllers



FEATURES

- Replaces all Siemens® S45 and S55 models
- Built-in Ethernet and USB ports for programming
- Built-in SD Flash card for program and documentation storage
- Built-in Profibus and RS485 Remote I/O on C200, C205 and C400 models
- Up to 1Mbytes memory, 8192 I/O points, 256PIW points and 512 alarm, depending on model
- Programmable using touch keypad

SPECIFICATIONS

Ports:
Ethernet: 100Mb/s, RJ45
RS232C: DB9 male
Profibus: 12Mb/s, DSD female
Remote I/O: DB9 male
SD Flash card: up to 16 Kbytes
Expansion port: future use

Use Memory:
2500-C100: 128K
2500-C200: 256K
2500-C300: 512K
2500-C400: 3872K

Logic Elements:
2500-C100: 8K I/22
2500-C200: 8K I/28
2500-C300: 51K I/52
2500-C400: 91K I/52

Status Display: 3-Digit LED display for system status, error reporting and IP address

Backplane Power: 7 Watts (maximum)

Operating Temperature: 0° to 60°C
Storage Temperature: -40° to 80°C
Relative Humidity: 5% to 95%

Agency Approvals: CE
Agency Approvals Pending: UL, IEC, Class 1 Div 2

Shipping Weight: 1.5 lb. (0.68 Kg)

Control Technology Inc.
2744 Millersburg Pike, Knoxville, TN 37921-0962
Phone: 855/584-5462 Fax: 615/584-2720 www.controltechnology.com

Complete specifications and user guide for the 2500 Series® Processors can be found on the CTI web site:

2500 Series® Processor Product Bulletin
[http://www.controltechnology.com/Files/Products/2500-\(Classic\)/2500-Cxxx/bulletin/ProductBulletin](http://www.controltechnology.com/Files/Products/2500-(Classic)/2500-Cxxx/bulletin/ProductBulletin)

2500 Series® Processor Installation and Operation Guide
[http://www.controltechnology.com/Files/Products/2500-\(Classic\)/2500-Cxxx/manuals/CTI-2500-IOG-\(62-370\)](http://www.controltechnology.com/Files/Products/2500-(Classic)/2500-Cxxx/manuals/CTI-2500-IOG-(62-370))

1.3.2 2500 Series® Remote Base Controller

Each remote base in the system connects to the I/O network using a Remote Base Controller (RBC). The 2500-RIO-B RBC operates the I/O in the remote base and communicates to the processor.

2500-RIO-A RS-485 Remote Base Controller



Specifications

Ports:
RS485: 9-pin female
RS232C: 9-pin male

Communication Rate: 1Mbit/sec

Communication Port Isolation: 1500 VDC

Output State Selection:
Determines state of outputs when I/O channel communication is lost
off
all outputs hold their last value

Switch Options:
RBC address
Serial port baud rate

Backplane Power: 2 Watts (maximum)

Module Size: DIN rail wide

Operating Temperature:
0° to 60°C (32° to 140°F)
Storage Temperature:
-40° to 80°C (-40° to 185°F)

Relative Humidity: 5% to 95% (non-condensing)

Agency Approvals Pending: UL, IEC, FM Class 1, Div 2, CE

Shipping Weight: 1.5 lb. (0.68 Kg)

Control Technology Inc.
2744 Millersburg Pike, Knoxville, TN 37921-0962
Phone: 855/584-5462 Fax: 615/584-2720 www.controltechnology.com

Complete specifications and user guide for the 2500-RIO-B can be found on the CTI web site:

2500-RIO-B Product Bulletin
[http://www.controltechnology.com/Files/Products/2500-\(Classic\)/2500-RIO-B/product-bulletin/2500-RIO-B_product_bulletin](http://www.controltechnology.com/Files/Products/2500-(Classic)/2500-RIO-B/product-bulletin/2500-RIO-B_product_bulletin)

2500-RIO-B Installation and Operation Guide
[http://www.controltechnology.com/Files/Products/2500-\(Classic\)/2500-RIO-B/manuals/6200428-010](http://www.controltechnology.com/Files/Products/2500-(Classic)/2500-RIO-B/manuals/6200428-010)

Although we recommend the use of 2500-RIO-B Remote Base Controllers, the use of Siemens® 505-6851-A and 505-6851-B is also permitted. Additionally, Texas

Instruments 500-5114-A RBCs can be used.

1.3.3 Network Cabling & Taps

Standard RS-485 cabling is used to construct the network. All cabling should use high quality industrial-grade cable. Specific recommendations for cable types is included in Section 2.3.

For best results, use CTI 2500-TAP RS-485 network taps for attaching trunkline sections and droplines. These taps use an impedance-controlled design for highest noise immunity and include built-in termination resistance which can be easily switched in- or out- of the circuit using a toggle switch. They also include an electrical noise bleed path to chassis ground which can improve the noise immunity of your network.

**2500 Series PLC System
Product Bulletin**

**2500-TAP
Remote I/O Network Tap**



Installation Instructions

Trunklines are to the left and right ports of the tap. Droplines are attached to the bottom port.

Prepare Trunkline or Dropline Cable

- Strip back 30mm (1.2 in.) of the sheathing on both ends of the cable. There are three wires exposed when the sheathing is stripped back. Two wires have color-coded insulation jackets and one (the shield) is bare.
- At both ends of the cable, remove 0.13 in. (3.3 mm) of each color-coded insulation jacket (both ends) to expose the bare wires.

Connecting the Trunkline or Dropline to the tap

- Loosen three terminal screws on the terminal block.
- Insert the stripped wires being careful to observe the proper + / - / G location.

NOTE: Ensure that the bare shield wire is not touching the metal housing of the tap.

NOTE: Throughout your installation, make connections carefully to prevent wire misconnections. Before beginning your wiring, select your noise mode for a test, and be sure to follow the code in each tap connection and each IBC's operation.

- Tighten the screws on the terminal block.
- If this tap will be an "end" tap in the network, requires terminating resistor, be sure to switch the CTI termination resistor to either the "200ohm" or "100ohm" position, depending on the cable type being used.

NOTE: The terminating resistor value depends on the type of cable being used, and should match the characteristic impedance of the cable.

Description

The 2500-TAP Remote I/O Network Tap is specially designed for attaching trunkline and dropline sections to create 2500 Series Remote I/O networks. These taps use an impedance controlled design for highest noise immunity and include built-in termination resistance which can be easily switched in- or out- of the circuit using a toggle switch. They also include an electrical noise bleed path to chassis ground which can improve the noise immunity of your network.

Features

- dust and water resistant installation
- impedance controlled design
- built-in terminating resistance
- electrical noise bleed system for improved noise immunity

Control Technology Inc.
1711 Midwestern Way, Lincoln, NE 68502
Phone: 402.441.0402 Fax: 402.441.0722 www.controltechnology.com

©2008 Control Technology Inc. All Rights Reserved. CTI-P/N 06200382-000 (REV08)

Complete specifications and user guide for the 2500-TAP can be found on the CTI web site:

2500-TAP Product Bulletin
[http://www.controltechnology.com/Files/Products/2500-\(Classic\)/2500-TAP/product-bulletin/06200382_010](http://www.controltechnology.com/Files/Products/2500-(Classic)/2500-TAP/product-bulletin/06200382_010)

1.3.4 Network Terminations

2500 Series® Remote I/O networks **must** be properly terminated to ensure reliable operation. Guidelines for network termination are included in Section 2.4 below. For best results, use CTI 2500-TAP network taps with built-in terminations.

CHAPTER 2 DESIGN & INSTALLATION

The design and installation of the CTI 2500 Series® Remote I/O network consists of the following steps:

1. Plan and specify I/O network requirements
2. Specify and design the network topology
3. Specify cable type
4. Specify terminations
5. Document the I/O network
6. Construct the I/O network
7. Commission the I/O network

2.1 Plan and Specify I/O Network Requirements

Before you begin design the network and selecting components, be sure you have collected all requirements of the network:

How many remote I/O bases will be included?

Where will the 2500 Series® Processor be installed?

Where will each I/O base be installed?

What is the distance between each I/O base and the processor?

Are there allowances made for routing I/O cables properly (see Section 2.6.1)?

Is space allocated for mounting network taps?

2.2 Specify and design the network topology

With information about the number of bases, distances from the processor to each base, and possible routing paths, you can begin to select and design the network topology. Read the information below on topology and design considerations. Then, following the guidelines included here and the constraints of your cable routing paths, develop a network configuration using trunklines and droplines which interconnects your I/O bases.

2.2.1 Select Basic Network Topology

The first step in designing the network is to select the basic network topology, based on location of equipment and maximum length between the processor and the most distance base, as shown in Figure 2-1. The maximum allowable trunk length depends on the number of bases (taps) in the network and the cable type being used. The table below shows maximum trunk length for each cable type.

Number of Terminal Blocks	Maximum Distance			
	Belden 3105A	Belden 9182	Belden 9271	Belden 9860
2 - 5	2200 ft (670 m)	2200 ft (670 m)	1100 ft (335 m)	3300 ft (1006 m)
6	2133 ft (650 m)	2133 ft (650 m)	1067 ft (325 m)	3200 ft (975 m)
7	2067 ft (630 m)	2067 ft (630 m)	1033 ft (315 m)	3100 ft (945 m)
8	2000 ft (610 m)	2000 ft (610 m)	1000 ft (305 m)	3000 ft (914 m)
9	1933 ft (589 m)	1933 ft (589 m)	967 ft (295 m)	2900 ft (884 m)
10	1827 ft (569 m)	1827 ft (569 m)	933 ft (284 m)	2800 ft (853 m)
11	1800 ft (548 m)	1800 ft (548 m)	900 ft (274 m)	2700 ft (823 m)
12	1733 ft (528 m)	1733 ft (528 m)	867 ft (264 m)	2600 ft (792 m)
13	1677 ft (508 m)	1677 ft (508 m)	833 ft (254 m)	2500 ft (762 m)
14	1600 ft (488 m)	1600 ft (488 m)	800 ft (244 m)	2400 ft (732 m)
15	1533 ft (476 m)	1533 ft (476 m)	767 ft (234 m)	2300 ft (701 m)
16	1400 ft (427 m)	1400 ft (427 m)	733 ft (223 m)	2200 ft (671 m)

Table 2-1 Maximum Trunk Length

Based on the maximum trunk length from the table, and requirements of your installation, select either the “Linear Network Configuration” or “T Network Configuration” from Figures 2-1 and 2-2 below. Note that the “T” network configuration allows you to double the maximum allowable trunk length.

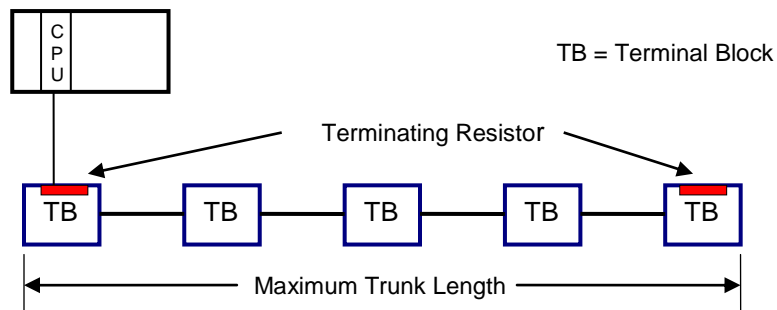

Figure 2-1 Linear Network Configuration

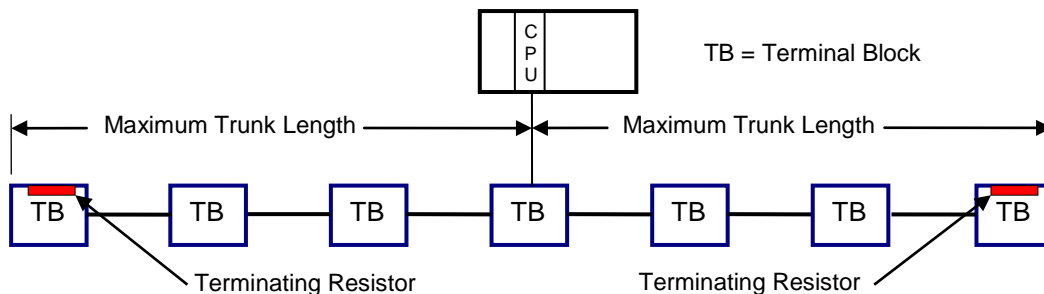

Figure 2-2 "T" Network Configuration

Example:

The I/O network will have 11 total bases, and will use Belden 9271 cable. From Table 2-1, the maximum allowable trunklength is 274m. Therefore, as long as the distance from the CPU to the farthest base is less than 274m, then the “Linear” configuration of Figure 2-1 can be used. If the distance is between 274m and 548m, then the “T” configuration must be used. If the distance is more than 548m, then Belden 9271 cable is not adequate for this installation, and you must use a higher grade of cable.

2.2.2 Placing Taps and Designing Droplines

Drop lines attached to each tap must be less than 10m (33 feet) in length. Any droplines longer than 1m (3.3 feet) must be added to the total trunk length, and the resulting trunk size must be within the limits of Table 6-2 for your network configuration and cable type.

When multiple connections are required in close proximity, you should connect the equipment to a single terminal block instead of dedicating a terminal block to each connection. See the figure below for connection options.

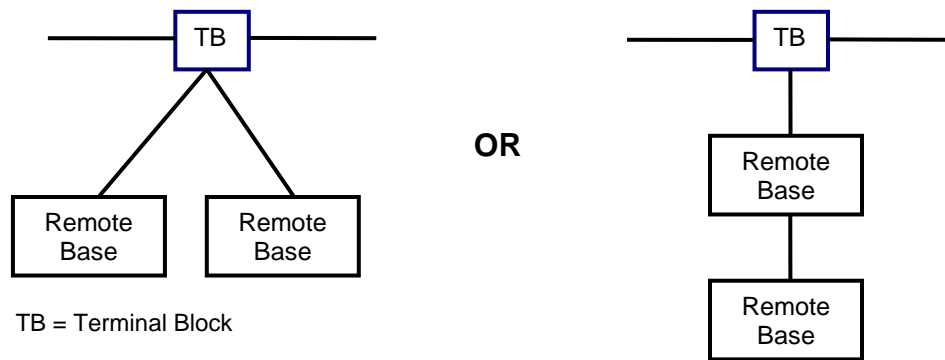

Terminal Block connections to the trunk line must be spaced so that the total length of the trunk line separating the taps is greater than the sum of the drop line lengths at the taps. In the illustration below, L1 must be greater than the sum of L2 + L3.

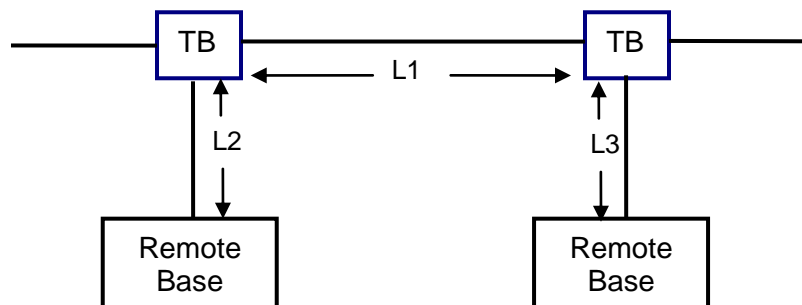

2.2.3 Dual Media and Hardware Redundancy Installations

A pair of 2500-RIO-B RBC's may be installed in a 2500-R11-A or 505-6511 redundant base to provide dual media as well as hardware redundancy. In a redundant configuration, two 2500-RIO-B units are installed in the base and separate cable runs are used to provide redundancy in both the hardware and communications cabling between the CPU and the remote base. The dual RBCs function in an active/standby configuration. A loss of communications to the active RBC will result in switching to the standby RBC with no change to system outputs.

Pictured in figure 1 is an example of a typical hardware and cabling layout for achieving dual media redundancy. The 2500-Tap RS-485 Remote I/O Tap and Terminator is required for dual media applications.

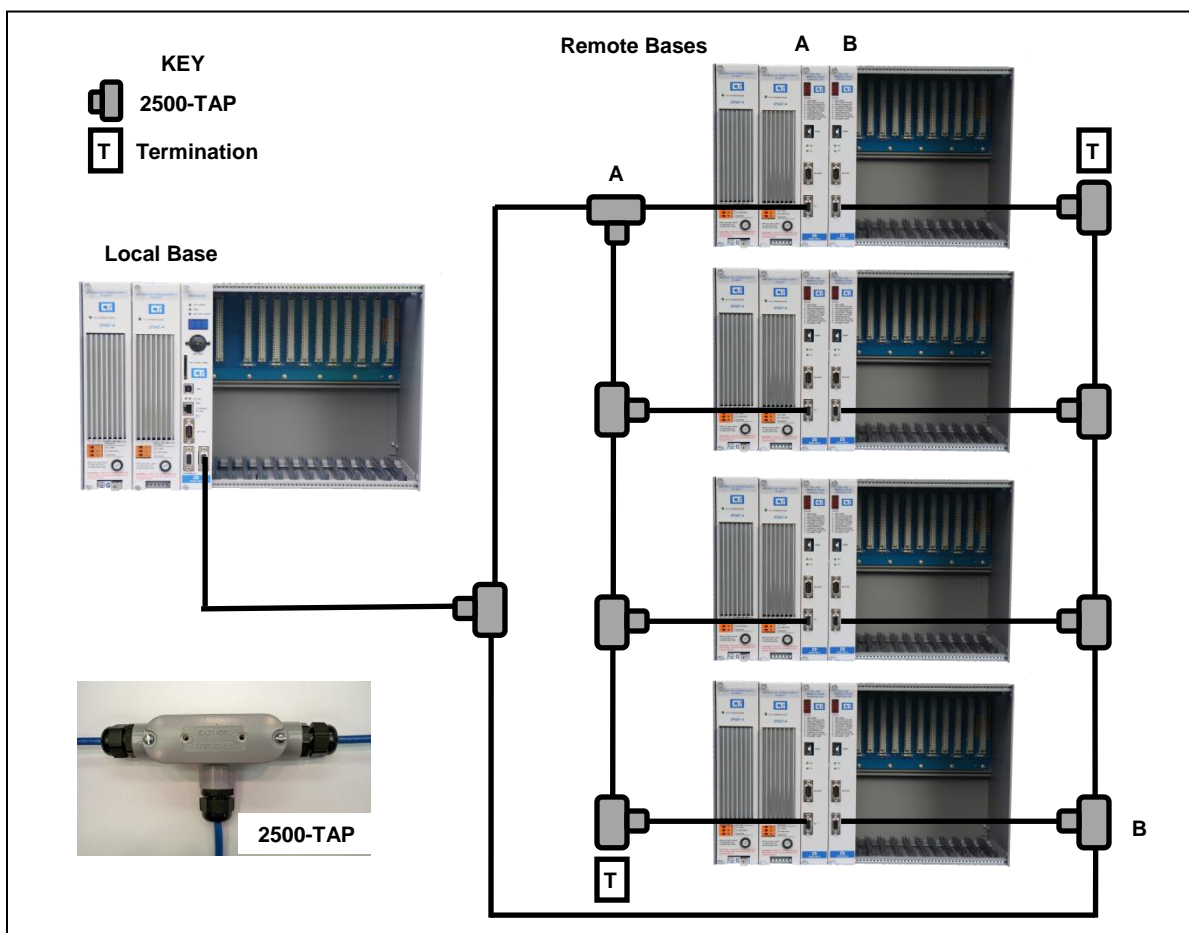

Figure 1: Typical Dual Media Redundancy Layout

Pictured in figure 2 is an example of the recommended hardware and cabling layout for achieving optimum dual media redundancy. The recommended RIO connector is made by Phoenix Contact and the model number is 2761826.

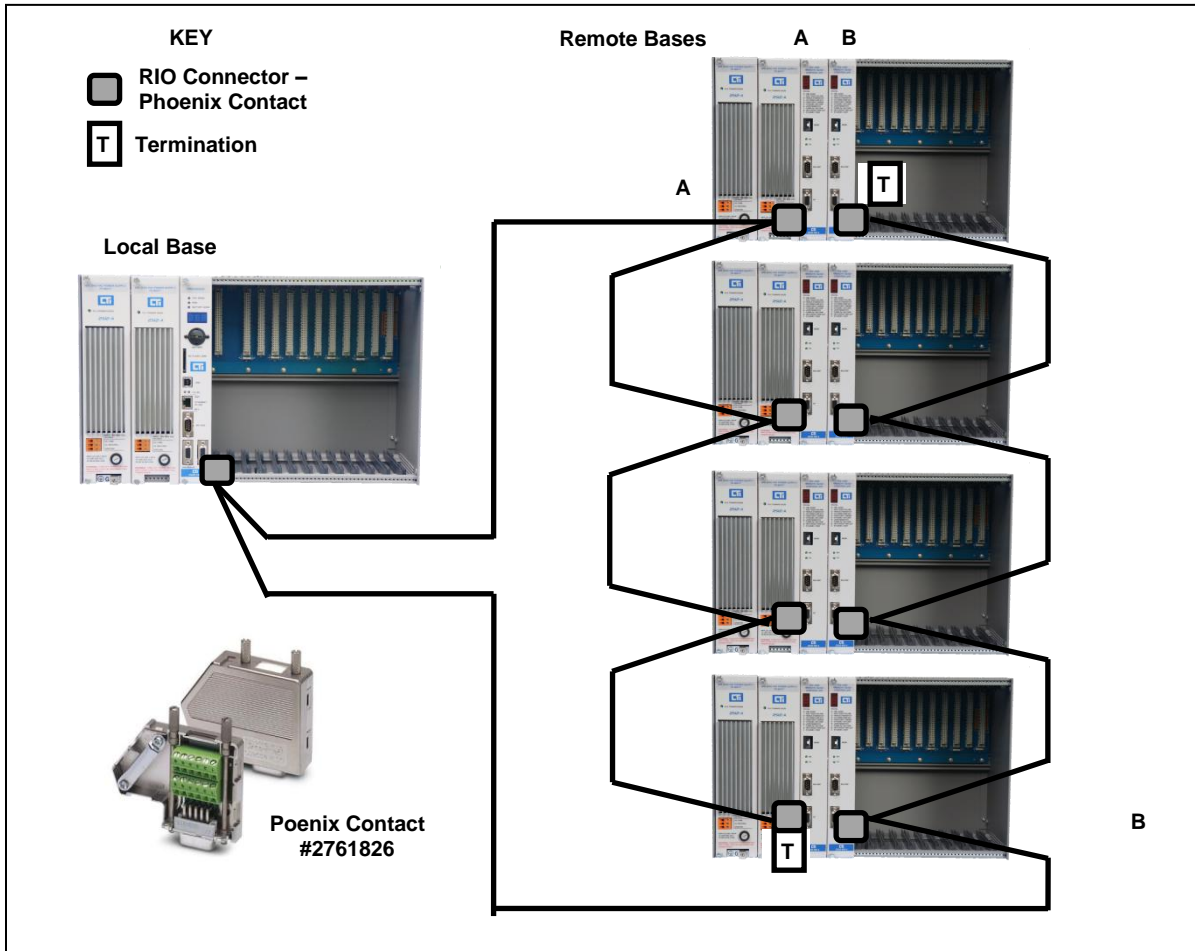

Figure 2: Recommended Dual Media Redundancy Layout

Termination resistors must be installed at the ends of the trunk line, as shown in figure 2. The resistor value required depends on the trunk cable as specified in section 2.4. The terminating resistor is installed between terminal numbers 3 and 8, the transmit and receive lines.

2.3 Specify cable type

Based on your topology selection and distances, specify the cable type to be used based on the information included below.

The following cables (or equivalent) are acceptable for use for remote I/O connections.

Belden Cable Type	Outside Diameter	Impedance	Capacitance	Velocity	Center Conductor
3105A	.281 in 7.1 mm	120 ohm	36 pf/m	0.78c	22 AWG 7x30 48.2 ohm/km
9182	0.35 in. 8.9 mm	150 ohm	28.9 pf/m	0.78c	22 AWG 19x34 46 ohm/km
9271	0.24 in 6.1 mm	124 ohms	40 pf/m	0.66c	25 AWG 7x33 104.3 ohm/km
9860	0.44 in. 11.2.mm	124 ohms	35.8 pf/m	0.78c	16 AWG Solid 13.8.ohm/km

Belden 9182 and 3105A are suitable for intermediate length trunk lines. These cables cannot be intermixed with other cables for trunk lines. In addition, if either of these cables are used for a trunk line, they must also be used for all drop lines. They may also be used for drop lines with Belden 9860 or Belden 9271 trunk lines.

Belden 9271, which is smaller and more flexible, is suitable for use as drop lines as well as short trunk lines. For trunk lines, this cable may be intermixed with Belden 9860.

Belden 9860 cable, which provides low attenuation and distortion, should be used for long trunk lines.

NOTE: If the trunk line is Belden 9182, then the droplines must also be Belden 9182. If the trunk line is Belden 3105A, 9860, or 9271, then the droplines can be 3105A, 9271, or 9182.

If you use cable types other than these, you should ensure the following requirements are met:

- Characteristic impedance between 100 and 150 ohms (124 ohms optimum)
- High uniform twist and spacing of conductors (twinaxial cable)
- Shield coverage approaching 100%
- DC resistance smaller than the characteristic impedance
- Jacket suitable for the installation

2.4 Specify terminations

Termination resistors must be installed at the ends of the trunk line, as shown in Figure 2-1 and 2-2. The resistor value required depends on the trunk cable as specified in the table below:

Cable Type	Resistor Value
Beldon 3105A	120 ohms, 5%, 1/4 W
Belden 9182	150 ohms, 5%, 1/4 W
Belden [®] 9860 or 9271	120 ohms, 5%, 1/4 W

2.5 Document the I/O network

Before beginning construction of your network, it is important to make a detailed drawing of the network. During construction and commissioning, keep this drawing updated to reflect the “as built” configuration. Should you require technical support due to difficulties in network operation, this information will be need by CTI support representatives to help you.

As a minimum, the drawing should include:

Location of the processor and each remote base in the network
 Location of network taps
 Cable type and length for each segment of trunk line and drop line
 Location of value of network terminations

2.6 Construct the I/O network

2.6.1 General Cabling Guidelines

For highest reliability in remote I/O communications, it is important to observe proper cabling guidelines when constructing your network.

Take steps to bypass or eliminate noise sources in order to reduce system data error rates. The following are common sources of electrical noise.

- Power distribution mains
- Arcing motors and motor starters
- Fluorescent lighting
- Undesired signal transfer between adjacent circuits
- Poor terminations of cable connector

Do not allow the trunk cable to come into contact with any other electrical conductor. If cabling is installed inside a conduit, the conduit should be grounded according to applicable electrical codes.

IMPORTANT: Maintain a minimum of 3 feet (1 m) between trunk lines and the following noise sources.

- Power lines
- Electric motors and motor starters
- Variable speed drives

- Generators
- Electric welders

The type of routing is usually determined by the type of building in which the cables are being installed. Any combination of the following may be used to route the cables: under-floor, in-ceiling, or surface duct.

Consider the following general guidelines before installing any system or power wiring.

- Always use the shortest possible single length cable.
- Avoid placing system and field wiring in the vicinity of high-energy and/or high frequency wiring.
- Keep field input wiring, output wiring, and all other types of wiring in the panel physically separated when possible.
- Separate DC field wiring from AC field wiring wherever possible.
- Avoid sharp bends to power and data cables. Use 7.6 cm (3 inches) radius on all bends.
- Ensure that a good low earth ground impedance of 0.1 ohm or less exists for all components in the system.
- Use metal wireways and conduit when possible.
- Keep wire strippings from falling into modules, controllers, or bases.
- For long return lines to the power supply, do not use the same wire for input and output modules. Using separate return wiring for these modules minimizes the voltage drop on the return lines of the input connections.

2.6.2 Constructing Trunk Line Cables

Use the following procedure to prepare trunk line cables.

1. Strip back 38mm (1.5 in) of the sleeving on both ends of the cable. There are three wires exposed when the sleeving is stripped back. Two wires have color-coded insulation jackets and one (the shield) is bare.
2. At both ends of the cable, remove 3.3mm (0.13 in) of each color-coded insulation jacket (both ends) to expose the bare wires.

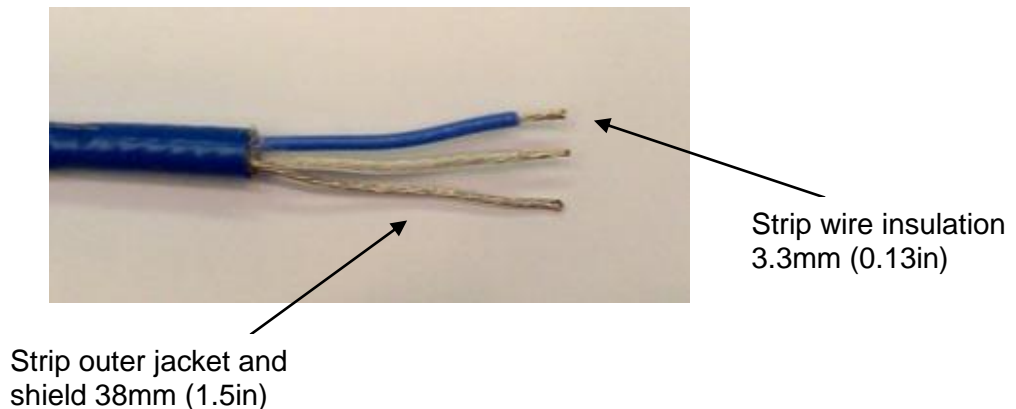

2.6.3 Connecting Trunk Lines to Taps

To connect a trunk line cable to a 2500-TAP terminal block, follow the steps below.

1. Loosen three terminal screws on the terminal block.
2. Insert the stripped wires being careful to observe the proper + / - / S location.

NOTE: Throughout your installation, make connections carefully to prevent wire mismatches. Before beginning your wiring, select your color code for + and -, and be sure to follow the code in each tap connection and each RBC connection.

3. Tighten the screws on the terminal block.
4. If this tap will be an “end” tap in the network (requires a terminating resistor), be sure to switch the ON the terminating resistor to either the 120Ω or 150Ω position, depending on the cable type being used.

NOTE: The terminating resistor value depends on the type of cable being used, and must match the characteristic impedance. As outlined in Section 2.4.

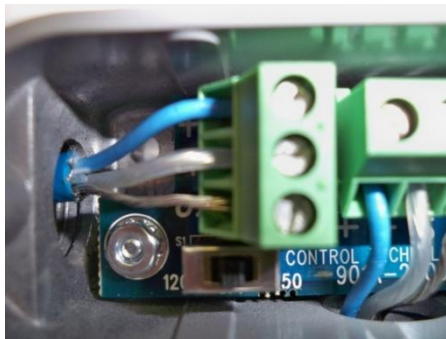

PROPER TRUNKLINE CONNECTION TO TAP

NOTE CORRECT STRIP LENGTH AND ATTACHMENT OF WIRES.

NOTE TERMINATION SWITCH IN THE “OFF” POSITION



INCORRECT WIRE CONFIGURATION

NOTE THAT SHIELD WIRE CONTACTS TAP HOUSING.

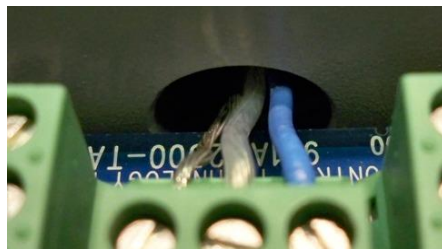

CORRECT WIRE CONFIGURATION

NOTE HOW SHIELD WIRE DOES NOT CONTACT TAP HOUSING



FINISHED TAP ASSEMBLY

NOTE TRUNKLINES AT LEFT AND RIGHT,
DROPLINE AT BOTTOM

2.6.4 Constructing Drop Line Cables

Use the following procedure to prepare drop line cables.

1. Strip back 38mm (1.5 in) of the sleeving on both ends of the cable. There are three wires exposed when the sleeving is stripped back. Two wires have color-coded insulation jackets and one (the shield) is bare.
2. At both ends of the cable, remove 0.13 in. (3.3 mm) of each color-coded insulation to expose the bare wires.

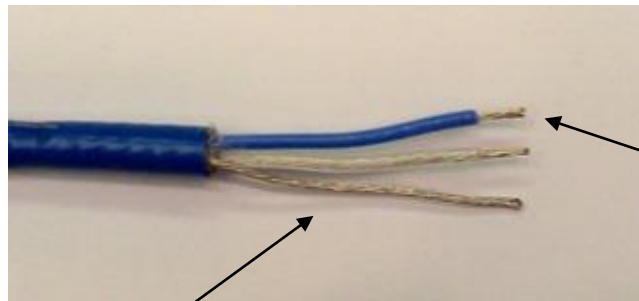

Strip outer jacket and
shield 38mm (1.5in)

Strip wire insulation
3.3mm (0.13in)

2.6.5 Connecting Drop Lines to Taps

To connect a drop line cable to a 2500-TAP terminal block, follow the steps below. Refer to the examples in Section 2.6.3.

1. Loosen three terminal screws on the terminal block.
2. Insert the stripped wires being careful to observe the proper + / - / S location.

NOTE: Throughout your installation, make connections carefully to prevent wire mismatches. Before beginning your wiring, select your color code for + and -, and be sure to follow the code in each tap connection and each RBC connection.

3. Tighten the screws on the terminal block.

2.6.6 Attach D-connector to Drop Line for Connection to 2500 Series® Processor or RBC

Each drop must have a 9-pin male D-connector attached to connect to a 2500 Series® Processor or 2500-RIO Remote Base Controller.

Install the wire without insulation to pin #5 of the 9-pin D-connector. Install the wires with the color-coded insulation to pins #3 and #8. It does not matter which wire is installed to pin #3 or #8, but all connectors must be installed identically and must follow the +/- color code you selected at the beginning of the installation.

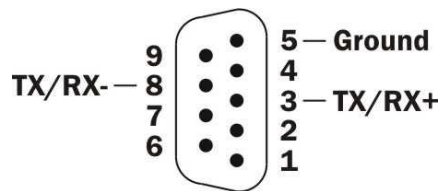

Figure 2-3 Remote I/O Connector Pinout

2.7 Commission the I/O network

When your network construction is completed, Perform the following checks and tests to ensure it is ready for operation.

- 1) Audit all wiring connections in the network and verify the following:
 - i) Proper cable type used (according to the drawing) for each network segment
 - ii) Length of each segment corresponds to the length noted on the drawing
 - iii) Proper strip length (38mm or 1.5in) is used where each segment connects to a tap or D-connector. Longer strip lengths increases the amount of noise coupled into the network and will adversely affect operation.
 - iv) Each cable is attached to the correct tap terminal. Trunk lines should connect to the sides of the "T". Drop lines should connect to the bottom of the "T".
 - v) Proper color code observed at every connection on every tap
 - vi) Shield connections are made for every cable at every tap
 - vii) Proper color code observed at every D-connector (to the proper pins)
 - viii) Shield connection made at every D-connector (to the proper pin)
 - ix) Network termination switches set properly at each tap
- 2) Verify network wiring and terminations by checking resistance.

- i) Disconnect all D-connectors from Processor and RBCs
- ii) Select a convenient tap and measure the following resistances:
 - (1) "+" to "-" resistance
 - (2) "+" to "shield" resistance
 - (3) "-" to "shield" resistance

Resistances measured should be as follows:

Trunk Cable Type	Belden 9860 / 9271 / 3105A		Belden 9182	
	Min	Max	Min	Max
"+" to "-"	52 ohms	70 ohms	63 ohms	87 ohms
"+" to "shield"	100K ohms	-	100K ohms	-
"-" to "shield"	100K ohms	-	100K ohms	-

- 3) Correct any discrepancies in wiring and resistance. If your measured resistance does not correspond to the values in the table, use the following steps to correct the network.

Resistance of "+" to "-" measures too low

Incorrect termination resistance installed
 More than two termination resistors installed
 Short in the cable

Resistance of "+" to "-" measures too high

Incorrect termination resistance installed
 Fewer than two termination resistors installed
 Open in the cable

Resistance of "+" to "shield" measures too low

One or more D-connectors are attached to CPU or RBC
 Short between "+" and "shield"

Resistance of "-" to "shield" measures too low

One or more D-connectors are attached to CPU or RBC
 Short between "-" and "shield"

- 4) Verify network communications
 - i) Power down 2500 Series® Processor and remove battery
 - ii) Power down all RBCs
 - iii) Attach D-connectors at all locations
 - iv) Apply power to processor and all RBCs.
 - v) All RBCs should read "7"
 - vi) Connect battery to processor
 - vii) Download program including I/O configuration
 - viii) On completion of download, all RBCs should change reading to "0" (if configurations of bases match program)

CHAPTER 3 SYSTEM CONFIGURATION

3.1 Configuring the 2500 Series® Processor

There are three steps to configuring the 2500 Series® Processor for operation with remote I/O.

1. Set the enable/disable status of each base in the system
2. Set the configuration and starting I/O address of each slot in each base

3.1.1 Setting the Enable/Disable status of each base

CTI 2500 Series® systems support up to 15 remote I/O bases. Each base number can be set in either a “disabled” or “enabled” status. The processor attempts to communicate every scan with all bases that are set to “enabled” regardless of whether they are actually present on the network. Therefore, a small performance advantage can be realized by setting unused bases to “disabled”.

To disable unused bases from PLC Workshop, use PLC UTILITIES – PLC CONFIGURATION – 505 I/O. In the I/O Configuration dialog box, set any unused bases to “disabled”. See the screen shots on the following page for an example.

PLC CONFIGURATION DIALOG BOX

Processor Information

PLC Type: CTI 2500

Total System Memory (Kbytes): 3072

Configured Memory (Kbytes): 192

Remaining Memory (Kbytes): 2880

I/O Status Scan Time

I/O Configuration

505 I/O Profibus I/O Find I/O

PLC Date/Time

Sun Jan 2, '00 0:01:43

Set

Miscellaneous

Watchdog Timer (ms): 1000

Faults Accept Cancel Close

Memory Configuration

	User	System
Ladder (Kb):	32	96
Variable (Kb):	52	52
Constant (Kb):	0	0
Special (Kb):	32	32
Comp. Spec. (Kb):	0	0
User Sub (Kb):	0	0
Global (K):	0	
T/C (K):	1	5
Drums:	64	3
Shift Reg (K):	1	1
Table (K):	1	2
One Shots (K):	1	1
Controls (K):	32	
I/O (K):	8	

I/O CONFIGURATION DIALOG BOX

Channel: 1

Base Status

Base	Enabled	Configured	Online
0	Yes	Yes	Yes
1	Yes	No	No
2	Yes	No	No
3	Yes	No	No
4	No	No	No
5	No	No	No
6	No	No	No
7	No	No	No
8	No	No	No
9	No	No	No
10	No	No	No
11	No	No	No
12	No	No	No
13	No	No	No
14	No	No	No
15	No	Yes	No

Enable Base(s)

Disable Base(s)

Edit Base...

Close

3.1.2 Set Slot Configuration and Starting I/O Address

For each slot in each base in the system, you must set the slot configuration (number of X, Y, WX, WY addresses) and the starting address of the I/O slot. To set the slot configuration from PLC Workshop, use PLC UTILITIES – PLC CONFIGURATION – 505 I/O – EDIT BASE – EDIT SLOT.

EDIT I/O BASE DIALOG BOX

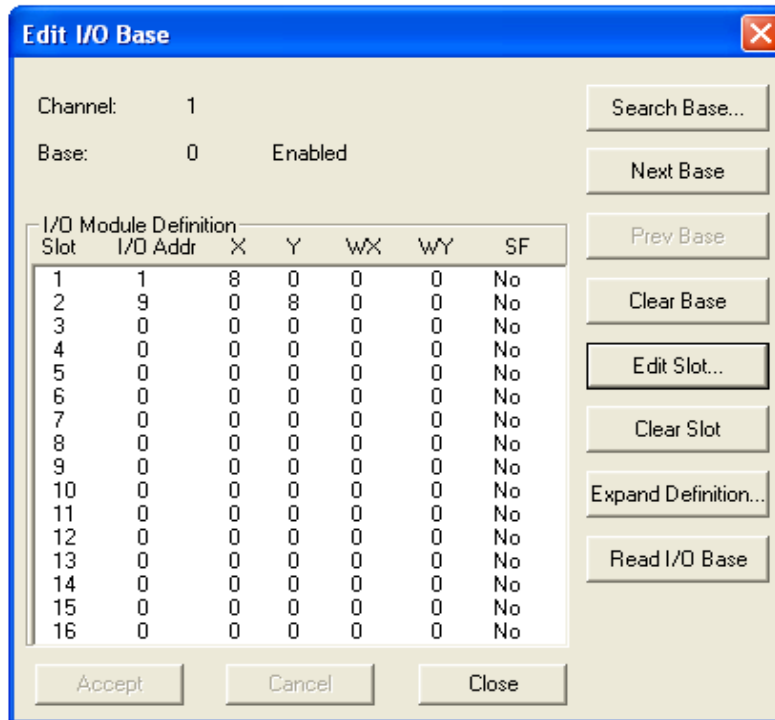

EDIT I/O SLOT DIALOG BOX



3.2 Configuring the 2500-RIO Remote Base Controller

There are three steps to configuring the RBC and making it fully operational:

1. Setting the RS232 Port baud rate
2. Setting the Remote Base Controller address
3. Setting the output state on communication loss (Freeze Jumper)

The figure to the right indicates the location of the RS232 port baud rate selection switches, the RBC station address thumbwheel, and Freeze Jumper. The remainder of this section describes the function of the individual settings.

3.2.1 Setting the RS232 Port Baud Rate

Switches SW1-SW4 are used for setting the baud rate of the RS-232 serial port. The supported baud rates are shown in the following table. All other switch combinations are invalid.

Baud Rate	SW1	SW2	SW3	SW4
19200	1	1	0	1
9600	1	1	1	1
2400	0	1	1	1
1200	1	0	1	1
300	0	0	1	1

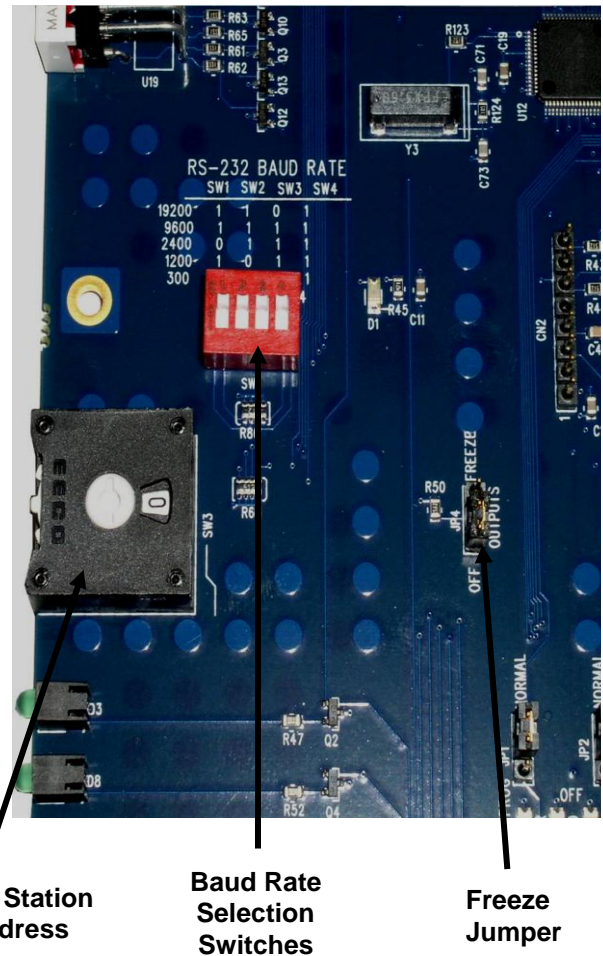

3.2.2 Setting Remote Base Controller Station Address

A thumbwheel switch is provided to set the base address to the 2500-RIO-B for Remote I/O station identification. A maximum of 15 remote bases can be connected to the CTI 2500 Series® CPU or Siemens® 545/555/575 CPU.

NOTE:
When connecting the 2500-RIO-B to a CTI 2500 Series® CPU or Siemens® 545/555/575 CPU, only addresses between 1 and 15 are valid. Each installed 2500-RIO-B must have a unique station number.

Care should be taken to prevent circumstances which cause the CPU to lose communication with the 2500-RIO-B while the system is operating. Loss of communication between the CPU and RBC will cause the base to be logged off from the CPU. This can cause intermittent process operation.

WARNING:

The following events will cause loss of communication with the 2500-RIO-B and result in the base being logged off from the CPU.

- 1) Duplication of the station address between RBC's attached to the same CPU (except in dual-media applications).**
- 2) Changing the thumbwheel switch station address while the system is operating.**

These events could cause unpredictable process operation and result in damage to equipment and/or serious injury to personnel.

When a base is logged off, the CPU zeroes all image register input points associated with the base and all outputs go to the value determined by the installed output module and the RBC for the base as shown in the next section.

Your program can monitor the CPU Status Words to detect this condition and control the outputs from other remote bases as appropriate for the application. Details on the Status Words and programming examples can be found in the CTI 2500 Series® Processor Programmers Reference Guide.

3.2.3 Setting the Output State on Communication Loss

When I/O channel communication to a remote base is lost, the state of the discrete outputs is determined by the selection made on the 2500-RIO-B jumper JP1 (Off/Freeze). The location of the jumper on the 2500-RIO-B is shown above in Section 3.2.1.

NOTE:

*The 2500-RIO-B ships with the FREEZE jumper in the OFF setting.
If the jumper JP1 is missing from the board, the 2500-RIO-B defaults to the OFF setting.*

For discrete output modules, the state of the outputs is determined solely by the position of the Off/Freeze jumper JP1 on the 2500-RIO-B.

For analog/word output modules, the state of the outputs is influenced not only by the position of the Off/Freeze jumper but by the output module's (Zero/Hold Last Value) selection, if the module has that option. See the table below.

RBC Off/Freeze Selection	Analog/Word Module Zero/Hold Selection	Analog/Word Output State
Off	Zero	Zero*
Off	Hold Last Value	Last Value
Off	No selection	Last Value
Freeze	Zero	Last Value
Freeze	Hold Last Value	Last Value
Freeze	No selection	Last Value
*see the user manual of your analog/word output module for details		

Notice that the FREEZE option on the RBC overrides the Zero selection on the analog/word output module; likewise, when Hold Last Value is selected on the analog/word output module, that selection overrides the OFF option on the RBC jumper.

WARNING:
If the RBC fails or loses power during system operation, all outputs will turn OFF(0) regardless of the Freeze Jumper setting. This could result in damage to equipment and/or serious injury to personnel.

CHAPTER 4 TROUBLESHOOTING

This section provides information that you may find useful in diagnosing and correcting problems you may encounter in 2500 Series® Remote I/O networks.

4.1 Commissioning instructions

If you experience trouble with your 2500 Series® Remote I/O network, the first step is to conduct the “Commissioning the Network” procedure in Section 2.7. Following this procedure will ensure at a base level that all network connections are proper and basic communications between the processor and RBCs is possible.

4.2 RBC setup and status indicators

Each remote base controller in the system requires several setup items before it will operate properly. If you experience problems with one or more RBCs, you should repeat the setup process from Section 3.3 above to verify all RBCs are properly configured.

The LED Display on the RBC is used to indicate the status of the 2500-RIO-B Remote Base Controller as shown in the following table:

Display	Definition	Communications to RBC	Comment / Action
0	RBC Good	OK	Fully Operational and online with CPU.
1	Diagnostics Failure	None	Serious malfunction. Place system in safe state and contact CTI Technical Support.
2	Module Mismatch	OK	I/O modules installed do not match the expected configuration in the CPU.
3	I/O Communications timeout	Failed	There is no communication with the CPU. Place the system in a safe state. Check power, cabling, and connection to the CPU.
4	Ram Parity Error	Failed	Serious malfunction. Place system in safe state and contact CTI Technical Support.
5	Standby, No Configuration	None	Standby RBC in dual-media application is not configured. Configure module.
6	Address Mismatch	OK	Dual-media RBC's must have identical station address. If addresses are equal, contact CTI Technical Support.

7	Communications OK, No Configuration	OK	2500-RIO-B is not configured. Configure RBC in CPU.
8	Watchdog timeout	Failed	Serious malfunction. Place system in safe state and contact CTI Technical Support.
blank	No Code Displayed	None	Serious condition. 2500-RIO-B is not operational. If power to base is OK, contact CTI Technical Support.
C	Standby unit configured	OK	Standby unit of a redundant pair is configured and communicating
A,B,E	Internal Error	Failed	Hardware failure detected during power on initialization tests.

4.3 I/O status configuration and status screens in WorkShop

The programming software PLC WorkShop includes a number of configuration and status screens which can be used to debug problems with remote I/O bases.

4.4 System status words

There are a number of system status words which are important in observing remote I/O system operation and isolating problems. If you are experiencing remote I/O problems, you should pay careful attention to the following status words.

STW2	Base controller status
STW11-26	I/O module status
STW145	Remote I/O receive errors
STW146	Remote I/O timeout errors
STW168	Dual RBC Status
STW184	I/O module mismatch
STW210	Remote I/O base poll enable flags
STW455-461	Remote base receive errors
STW471-485	Remote base abnormal logoff counts
STW487-501	Remote base timeout counts

More complete information and a list of the 2500 Series® Processor System Status Words can be found in the 2500 Series® Processor Installation and Operation Guide:

[http://www.controltechnology.com/Files/Products/2500-\(Classic\)/2500-Cxxx/manuals/CTI-2500-IOG-\(62-370\)](http://www.controltechnology.com/Files/Products/2500-(Classic)/2500-Cxxx/manuals/CTI-2500-IOG-(62-370))

4.5 Fatal and Non-Fatal Error Codes

Information regarding 2500 Series® Processor error codes can be found in the 2500 Series® Processor Installation and Operation Guide:

[http://www.controltechnology.com/Files/Products/2500-\(Classic\)/2500-Cxxx/manuals/CTI-2500-IOG-\(62-370\)](http://www.controltechnology.com/Files/Products/2500-(Classic)/2500-Cxxx/manuals/CTI-2500-IOG-(62-370))