

**2550-A
EIGHT CHANNEL
ISOLATED ANALOG INPUT MODULE
INSTALLATION AND OPERATION GUIDE**

Ver. 2.3

**Copyright © 2020 Control Technology Inc.
All rights reserved.**

This manual is published by Control Technology Inc., 5734 Middlebrook Pike, Knoxville, TN 37921. This manual contains references to brand and product names which are tradenames, trademarks, and/or registered trademarks of Control Technology Inc. 2500 Series® and Siemens® and SIMATIC® are registered trademarks of Siemens AG. Other references to brand and product names are tradenames, trademarks, and/or registered trademarks of their respective holders.

DOCUMENT DISCLAIMER STATEMENT

Every effort has been made to ensure the accuracy of this document; however, errors do occasionally occur. CTI provides this document on an "as is" basis and assumes no responsibility for direct or consequential damages resulting from the use of this document. This document is provided without express or implied warranty of any kind, including but not limited to the warranties of merchantability or fitness for a particular purpose. This document and the products it references are subject to change without notice. If you have a comment or discover an error, please call us toll-free at 1-800-537-8398.

PREFACE

This *Installation and Operation Guide* provides installation and operation instructions for the CTI 2550-A Eight Channel Isolated Analog Input Module for CTI's 2500 Series® and the SIMATIC® 505 programmable controllers. We assume you are familiar with the operation of CTI's 2500 Series® Classic series programmable controllers. Refer to the appropriate CTI's 2500 Series® user documentation for specific information on the CTI's 2500 Series® programmable controllers and I/O modules.

This *Installation and Operation Guide* is organized as follows:

Chapter 1 provides a description of the module.

Chapter 2 covers installation and wiring.

Chapter 3 is a guide to troubleshooting



The 2550-A 8-Channel Isolated Analog Input Module

USAGE CONVENTIONS

NOTE:

Notes alert the user to special features or procedures.

CAUTION:

Cautions alert the user to procedures which could damage equipment.

WARNING:

Warnings alert the user to procedures which could damage equipment and endanger the user.

Contents

CHAPTER 1. DESCRIPTION	1
1.1 Front Panel Description	1
1.1.1 Active LED	1
1.1.2 Input Connector for Channels 1-8.....	3
1.2 Asynchronous Operation	3
1.3 Immediate I/O.....	3
1.4 Unipolar or Bipolar Mode	3
1.5 Voltage or Current Mode.....	3
1.6 Digital Word Map.....	3
1.7 Analog to Digital Conversion.....	4
1.7.1 Unipolar Mode Conversion.....	4
1.7.2 Bipolar Mode Conversion.....	5
1.7.3 Example Conversion	5
1.8 Effect of Out-of-Range Input Signals.....	6
1.8.1 Unipolar Mode	6
1.8.2 Bipolar Mode	6
1.9 Using an Input with 20% Offset.....	8
1.9.1 Using the Module with 20% Offset	8
1.10 Resolution.....	9
CHAPTER 2. INSTALLATION	10
2.1 Planning the Installation	10
2.1.1 Calculating the I/O Base Power Budget.....	10
2.1.2 Input Signal Wiring.....	10
2.2 Unpacking the Module	11
2.3 Configuring the Module	11
2.3.1 Selecting Voltage or Current Input Mode.....	12
2.3.2 Selecting Voltage Range	12
2.3.3 Selecting Unipolar or Bipolar Input Mode	12
2.3.4 Selecting Digital Filtering	13
2.3.5 Selecting Offset Scaling	14
2.3.6 Selecting Advanced Operating Mode	14
2.3.7 Configuring DIP Switches to Report Hardware Configuration	14
2.4 Inserting the Module into the I/O Base	14
2.5 Wiring the Input Connectors	15
2.5.1 Connecting Voltage Input Wiring	15
2.5.2 Connecting Current Input Wiring	16
2.5.3 Connecting the Shield Wiring.....	16
2.6 Installing the Screw Terminal Connector.....	17
2.7 Checking Module Operation.....	18

CHAPTER 3. TROUBLESHOOTING.....	19
SPECIFICATIONS.....	21
JUMPER SETTINGS LOG SHEET.....	22
USER NOTES	24
LIMITED PRODUCT WARRANTY	26
REPAIR POLICY	28

TABLE OF FIGURES

Figure 1 2550-A Front Panel.....	1
Figure 2 Word Input to the PLC from the Module (Unipolar).....	4
Figure 3 Word Input to the PLC from the Module (Bipolar).....	4
Figure 4 Example of Change in Input Level.....	5
Figure 5 Voltage Input Limits (Unipolar).....	6
Figure 6 Voltage Input Limits (Bipolar).....	6
Figure 7 Overrange Word Value (Unipolar).....	7
Figure 8 Underrange Word Value (Unipolar).....	7
Figure 9 Overrange Word Value (Bipolar).....	7
Figure 10 Underrange Word Value (Bipolar).....	8
Figure 11 Input Resolution.....	9
Figure 12 Factory Configuration Jumper Settings.....	12
Figure 13 Configuration Jumper Locations.....	13
Figure 14 Screw Terminal Connector Wiring.....	15
Figure 15 Shield Wire Termination.....	17
Figure 16 Input Connector Assembly.....	17
Figure 17 Example I/O Configuration Chart.....	18
Figure 18 Troubleshooting Matrix.....	19
Figure 19 Jumper Settings Log.....	22

CHAPTER 1. DESCRIPTION

The Eight Channel Analog Input Module is a member of Control Technology's family of I/O modules compatible with the SIMATIC® 505 programmable controllers. The Model 2550-A is designed to translate an analog input signal into an equivalent digital word which is then sent to the programmable controller (PLC).

1.1 Front Panel Description

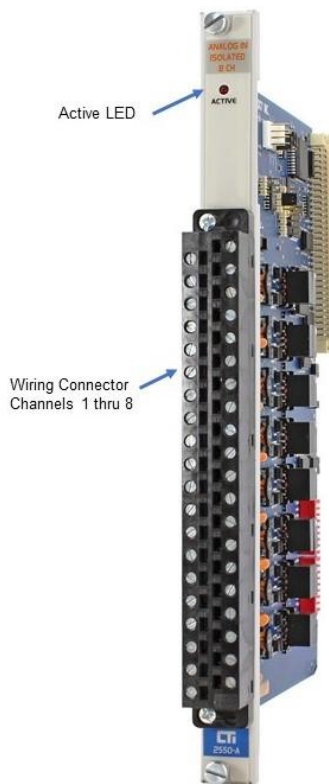

Figure 1 2550-A Front Panel

1.1.1 Active LED

The Active LED will be illuminated when the module is functioning normally. If the Active LED is not lit, or is blinking, refer to Chapter 3 for troubleshooting.

1.1.2 Input Connector for Channels 1-8

This connector provides wiring terminals for channels 1-8 for either voltage or current inputs.

1.2 Asynchronous Operation

The module operates asynchronously with respect to the PLC (a scan of the PLC and input sampling of the module do not occur at the same time). Instead, the module will translate all analog inputs in one module update (4 milliseconds maximum) and store the translated words in buffer memory. The PLC retrieves the stored words from the module buffer memory at the start of the I/O scan.

1.3 Immediate I/O

The Model 2550-A Analog Input Module is fully compatible with the Immediate input instruction for the SIMATIC® 545 and 555 PLCs.

1.4 Unipolar or Bipolar Mode

Each input channel may be configured to accept either bipolar or unipolar input signals. Selection of unipolar or bipolar mode is made via an internal jumper (see Section 2.3.3).

1.5 Voltage or Current Mode

Each of the module's eight channels may be configured to receive either voltage or current analog input signals. For unipolar input signals, the range is 0 to 5 VDC, 0 to 10 VDC or 0 to +20 mA. For bipolar input signals, the signal range is -5 to +5 VDC, -10 to +10 VDC or -20 to +20 mA. Selection of voltage or current mode and voltage range are made via internal jumpers (see Sections 2.3.1 and 2.3.2).

1.6 Digital Word Map

A unipolar analog input signal is translated into a 12-bit plus sign bit digital word. A bipolar input signal is translated into an 11-bit digital word plus 1-bit for the polarity sign. Since the PLC requires a 16-bit input word, the 12-bit value from the converter is placed into a 16-bit word for transmittal to the PLC. As shown in the following figure, of the four bits not used for the digital word, one is used to show the sign of the word, one is used to note values which are "overrange", and the remaining bits are not used and are set to zero.

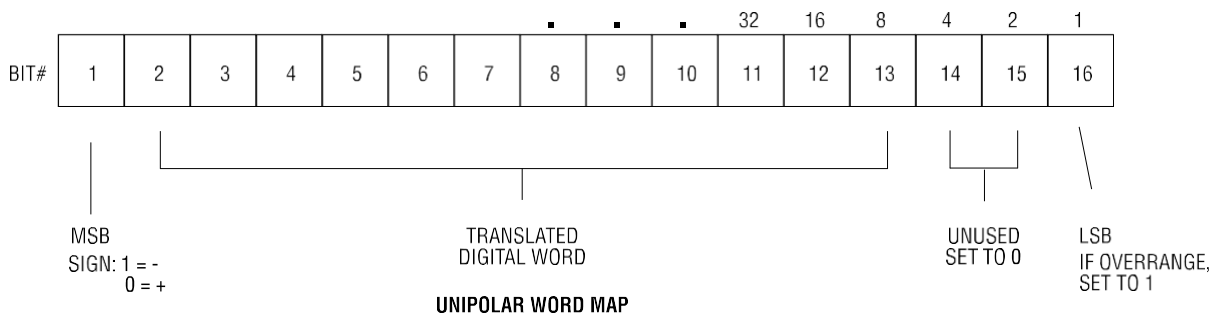

Figure 2 Word Input to the PLC from the Module (Unipolar)

As shown in the following figure, for a bipolar word input of the five bits not used for the digital word, one is used to show the sign of the word, one is used to note values which are “overrange”, and the remaining bits are not used and are set to zero.

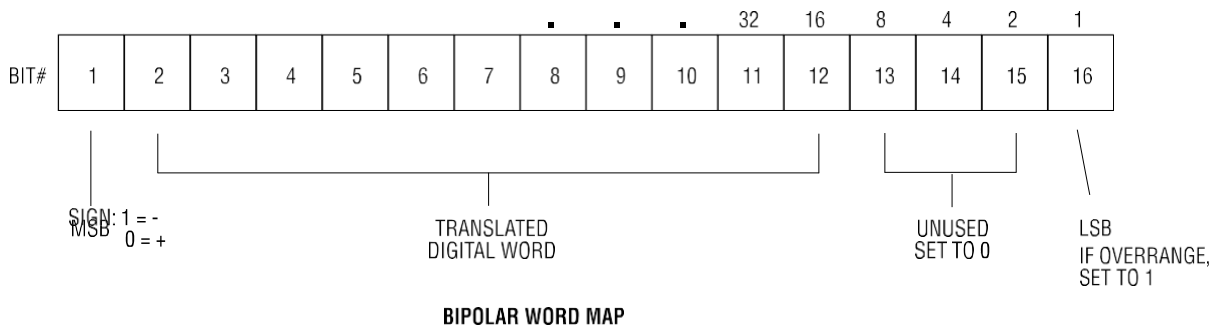

Figure 3 Word Input to the PLC from the Module (Bipolar)

1.7 Analog to Digital Conversion

1.7.1 Unipolar Mode Conversion

The following equations may be used to calculate the digital word which will result from a particular voltage or current input in the Unipolar input Mode:

$$0 \text{ to } 5\text{V Input Range Mode, Digital Word (WX)} = \frac{\text{Input voltage (V)} \times 32000}{5 \text{ volts}}$$

$$0 \text{ to } 10\text{V Input Range Mode, Digital Word (WX)} = \frac{\text{Input voltage (V)} \times 32000}{10 \text{ volts}}$$

$$0 \text{ to } 20\text{mA Input Range Mode, Digital Word (WX)} = \frac{\text{Input current (mA)} \times 32000}{20 \text{ mA}}$$

1.7.2 Bipolar Mode Conversion

The following equations may be used to calculate the digital word which will result from a particular voltage or current input in the Bipolar Input Mode:

$$\text{-5 to +5V Input Range Mode, Digital Word (WX)} = \frac{\pm \text{Input voltage (V)} \times 32000}{5 \text{ volts}}$$

$$\text{-10 to +10V Input Range Mode, Digital Word (WX)} = \frac{\pm \text{Input voltage (V)} \times 32000}{10 \text{ volts}}$$

$$\text{-20 to +20 mA Input Range Mode, Digital Word (WX)} = \frac{\pm \text{Input current (mA)} \times 32000}{20 \text{ mA}}$$

1.7.3 Example Conversion

As an example, the following figure illustrates the effects of a change in input level going from 1.25 to 2.5mV in the 0 to 5V Unipolar Input Mode. (For the 0 to 10V and 0 to 20mA Unipolar Input Modes, or the Bipolar Modes, refer to the formulas given in Sections 1.6.1 and 1.6.2 to determine the digital word which results from a particular input.)

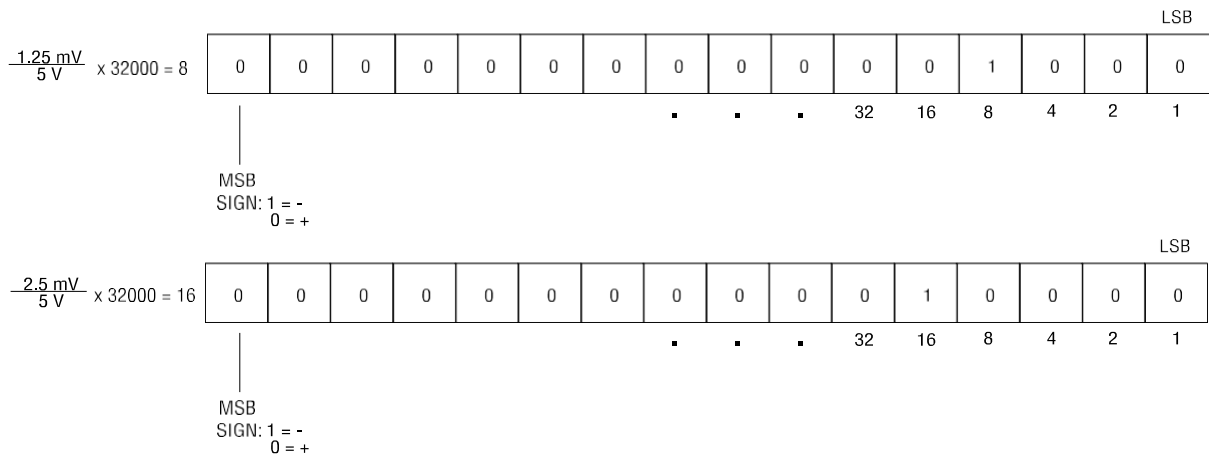

Figure 4 Example of Change in Input Level

1.8 Effect of Out-of-Range Input Signals

The Model 2550-A utilizes the overrange and underrange bit to indicate when a channel has reached individual limits. The value of the overrange or underrange condition varies from channel to channel. The reason for this is that as a channel is calibrated all of the gains and offsets and dynamic ranges of the analog to digital converter of the system are compensated for in each analog input channel. Therefore the point at which the analog to digital converter reaches a saturation point and can no longer produce a change in counts for corresponding change in input signal is called the overrange or underrange limit of the channel. This level is different for every channel. In the figures below, (sections 1.8.1 and 1.8.2), the limits for the overrange and underrange values are the minimum limits for a given channel. The actual limits for an individual channel may be greater.

1.8.1 Unipolar Mode

Signals falling below the lower limits in 0 to 5V Input Mode or 0 to 10V Input Mode are translated into a digital word that includes the addition of Bit 16 to indicate an overrange or underrange condition. Note that although the digital word may approach zero as the analog input signal approaches the minimum given range, the digital word will never actually be zero. In fact the underrange capability of any channel in Unipolar Mode may produce a negative value to the PLC for a number of counts before the underrange bit is set.

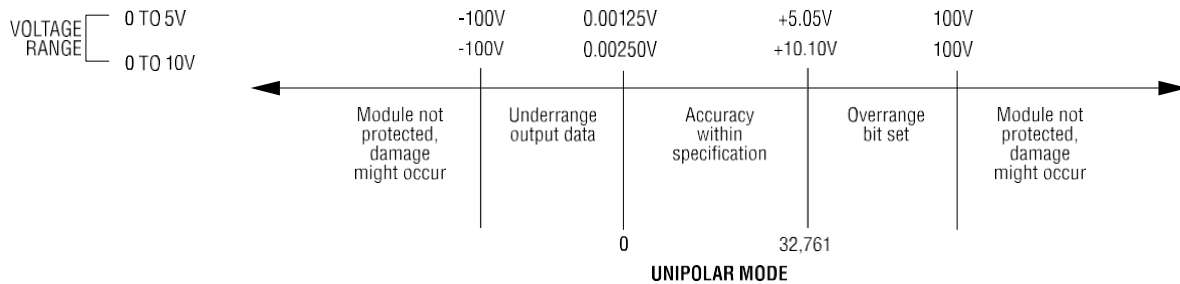

Figure 5 Voltage Input Limits (Unipolar)

1.8.2 Bipolar Mode

In Bipolar Mode signals above or below the upper and lower limits in the -5 to +5VDC or -10 to +10VDC range are translated to a digital word and also utilize the overrange and underrange bit. The actual limit for each channel will vary from channel to channel as described above.

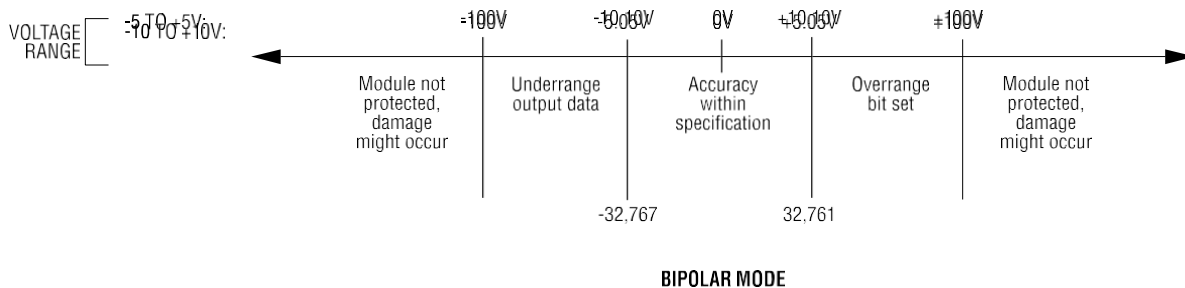

Figure 6 Voltage Input Limits (Bipolar)

Figures 7 and 8 show the binary values of typical overrange and underrange conditions for Unipolar mode.

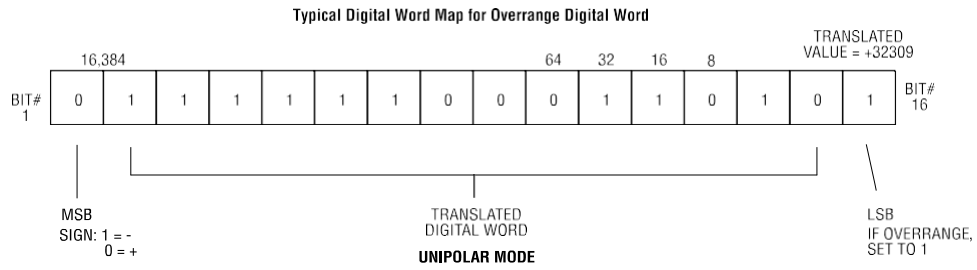

Figure 7 Overage Word Value (Unipolar)

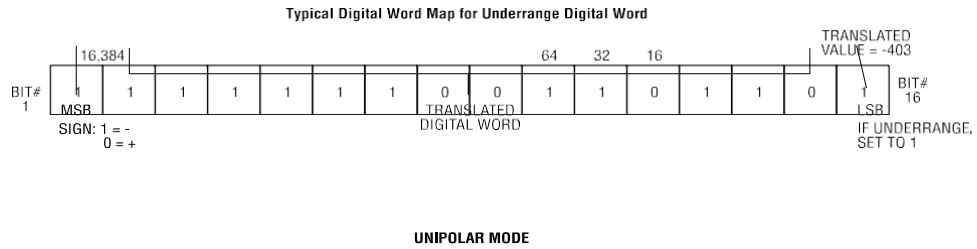

Figure 8 Underrange Word Value (Unipolar)

Figures 9 and 10 show the binary values of typical overrange and underrange conditions for Bipolar Mode.

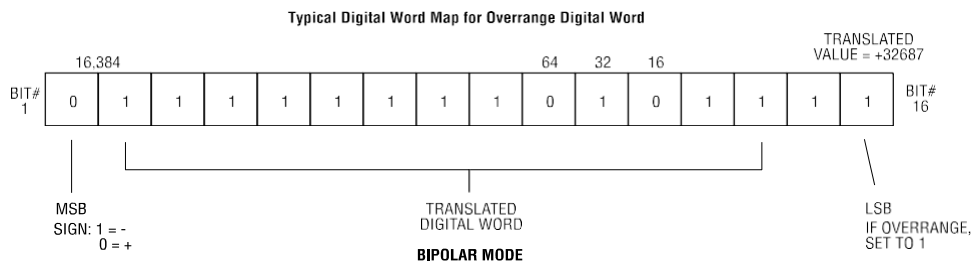

Figure 9 Overage Word Value (Bipolar)

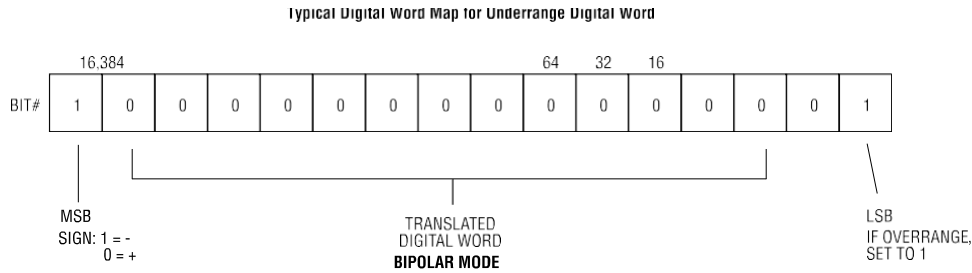

Figure 10 Underrange Word Value (Bipolar)

1.9 Using an Input with 20% Offset

Some applications use transducers that provide 1 to 5 volts (4 to 20mA) input signals instead of 0 to 5 volt (0 to 20mA) input signals. You can allow for this 20% offset by including some additional instructions in your RLL (Relay Ladder Logic) program.

First, subtract 6400 from the input data word (WX). Then, multiply the result by 125 and divide the product by 100. This yields the following equation:

$$(WX - 6400) \times 125 \div 100 = 20\% \text{ offset data word}$$

Consult your PLC programming manual (or program design guide) for information about RLL instructions used in the conversion.

1.9.1 Using the Module with 20% Offset

If all 8 inputs are used in offset mode the Model 2550-A may be configured to perform the offset calculation automatically. (See *Figure 13 Configuration Jumper Locations*). Jumper JP1 when enabled will configure the module such that all inputs will be scaled for 1-5VDC or 4-20mA operation. No further relay ladder logic is required for input processing.

NOTE:
*This function is new and was not supported in the original 2550 product.
 When enabled with JP1 all 8 inputs are scaled for offset mode.*

1.10 Resolution

In the Unipolar Input Mode, the module has a resolution of 8 counts out of 32000. That is the smallest unit into which the module will divide an input is 1 part out of 4000. This relationship can be shown as:

$$8 \text{ counts per step} \div 32000 \text{ counts full scale} = 1/4000$$

In Bipolar Mode, the resolution is 16 counts out of 32000, so that the smallest unit into which the module will divide an input is 1 part out of 2000. This relationship can be shown as:

$$16 \text{ counts per step} \div 32000 \text{ counts full scale} = 1/2000$$

When using the module with 20% offset, module resolution remains at 8 counts out of 32000, but offset resolution increases to 10 counts out of 32000 as a result of the multiplication and division of the incoming data word.

The chart below shows the corresponding input resolution per step for each of the input configuration modes:

	RANGE CONFIGURATION	DIGITAL COUNTS / STEP	INPUT RESOLUTION PER STEP
UNIPOLAR	0 - 5 VDC	8	1.25 mV
	0 - 10 VDC	8	2.5 mV
	0 - 20 mA	8	5 μ A
UNIPOLAR WITH 20% OFFSET	1 - 5 VDC	10	1.25 mV
	4 - 20 mA	10	5 μ A
BIPOLAR	-5 TO +5 V	16	2.5 mV
	-10 TO +10 V	16	5 mV
	0 - 20 mA	16	10 μ A

Figure 11 Input Resolution

CHAPTER 2. INSTALLATION

The installation of the Eight Channel Analog Input Module involves the following steps:

1. Planning the installation
2. Configuring the module
3. Inserting the module into the I/O base
4. Wiring and connecting the module input connectors
5. Checking module operation

The steps listed above are explained in detail in the following pages.

2.1 Planning the Installation

Planning is the first step in the installation of the module. This involves calculating the I/O base power budget and routing the input signal wiring to minimize noise. The following sections discuss these important considerations.

2.1.1 Calculating the I/O Base Power Budget

The Model 2550-A requires 5.2 watts of +5V power from the I/O base. Use this value to verify that the base power supply is not exceeded.

2.1.2 Input Signal Wiring

Input signal wiring must be shielded twisted pair cable. A twisted pair will aid in the rejection of conducted and radiated interference from other energy sources. Standard practices usually require that all shields be tied together and grounded at a single point.

Note the following general considerations when wiring the module:

- Always use the shortest possible cables
- Avoid placing low voltage wire parallel to high energy wire (if the two wires must meet, cross them at a right angle)
- Avoid bending the wire into sharp angles
- Use wireways for wire routing
- Avoid placing wires on any vibrating surface

2.2 Unpacking the Module

Open the shipping carton and remove the special anti-static bag which contains the module.

CAUTION:
HANDLING STATIC SENSITIVE DEVICES

The components on the Model 2550-A module printed circuit card can be damaged by static electricity discharge. To prevent this damage, the module is shipped in a special anti-static bag. Static control precautions should be followed when removing the module from the bag, when opening the module, and when handling the printed circuit card during configuration.

After discharging any static build-up, remove the module from the static bag. **Do not discard the static bag. Always use this bag for protection against static damage when the module is not inserted into the I/O backplane.**

2.3 Configuring the Module

The Model 2550-A must be configured for voltage or current inputs, voltage range, unipolar/bipolar mode, and digital filtering/no filtering mode before wiring the input connectors and inserting the module into the I/O base. As shipped, all input channels are configured for current inputs, 5V range (see note below), unipolar mode, digital filtering enabled, and offset scaling disabled (see *Figure 12 Factory Configuration Jumper Settings*).

NOTE:
The 5V input signal range configuration is used for both 0 to 5VDC and 1 to 5VDC or 4 to 20mA and 0 to 20mA input signal ranges.

Changing the module input channel configuration involves the following steps:

1. Selecting voltage (V) or current (I) input mode for each channel
2. Selecting 0 to 5V or 0 to 10V voltage range for each channel
3. Selecting unipolar or bipolar input mode for each channel
4. Selecting digital filtering or no filtering for the module
5. Selecting offset scaling for the module
6. Selecting 8WX or 16WX Advance Mode for the module (Advanced Mode not supported in this release).
7. Configuring DIP switches to report the hardware selections to the microcomputer
8. Logging the configuration jumper settings for future reference.

Each of these steps is described in the following sections.

2.3.1 Selecting Voltage or Current Input Mode

Locate the 8 Voltage/Current Jumpers corresponding to input channels 1 through 8. See Figure 14 for the location of these jumpers. For each input channel, select current mode by placing the jumper in the “I” position or voltage mode by placing the jumper in the “V” position. For each input channel set to current mode, you must set the corresponding Voltage Range Jumper to the 5V position as described in the following section.

2.3.2 Selecting Voltage Range

Locate the Voltage Range Jumpers corresponding to input channels 1 through 8 (see Figure 14). For each input channel operating in current mode, set the corresponding Voltage Range Jumper to 5V.

CAUTION:
For each input channel configured for current mode, the corresponding Voltage Range Jumper must be set 5V or damage will result to the module.

For each input channel operating in voltage mode, set the corresponding Voltage Range Jumper to 5V for 0 to +5V or -5V to +5V input range or 10V for 0 to +10V or -10 to +10V input range.

CHANNEL NUMBER	VOLTAGE CURRENT JUMPER	JUMPER POSITION V or I	VOLTAGE RANGE JUMPER	JUMPER POSITION 5V or 10V	UNIPOLAR/ BIPOLAR JUMPER	JUMPER POSITION
1	JP13	I	JP17	5V	JP21	UNI
2	JP14	I	JP18	5V	JP22	UNI
3	JP15	I	JP19	5V	JP23	UNI
4	JP16	I	JP20	5V	JP24	UNI
5	JP25	I	JP29	5V	JP33	UNI
6	JP26	I	JP30	5V	JP34	UNI
7	JP27	I	JP31	5V	JP35	UNI
8	JP28	I	JP32	5V	JP36	UNI

ALL CHANNELS	OFFSET SCALING JUMPER	JUMPER POSITION	DIGITAL FILTERING JUMPER	JUMPER POSITION	ADVANCED OPERATING MODE JUMPER	JUMPER POSITION
1 - 8	JP1	DISABLED	JP3	ENABLE	JP2	8 WX Standard Mode

Figure 12 Factory Configuration Jumper Settings

2.3.3 Selecting Unipolar or Bipolar Input Mode

Locate the Unipolar/Bipolar Jumpers JP21-24 and JP33-36 (see *Figure 13 Configuration Jumper Locations*). Set each jumper to UNI for unipolar operation or BIP for bipolar operation for each input channel.

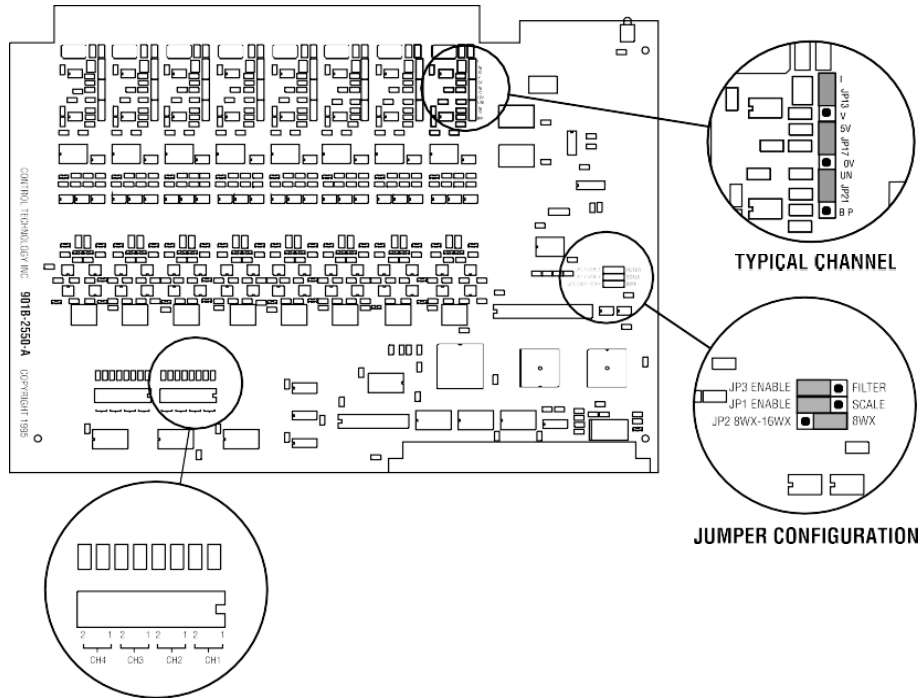

Figure 13 Configuration Jumper Locations

NOTE:
 For Factory Default see Figure 12 Factory Configuration Jumper Settings. Figure 13 Configuration Jumper Locations is only a visual reference for Jumper and Switch locations.

2.3.4 Selecting Digital Filtering

Locate the Digital Filtering Jumper JP3 (see *Figure 13 Configuration Jumper Locations*). To enable digital filtering, set the jumper in the ENABLE position. Since many analog input signals contain noise, CTI recommends using digital filtering unless maximum response time is required. As shipped digital filtering is enabled for all 8 analog inputs.

2.3.5 Selecting Offset Scaling

Locate the SCALE jumper (see *Figure 13 Configuration Jumper Locations*). To enable offset scaling for all 8 inputs set the jumper to the ENABLE position.

2.3.6 Selecting Advanced Operating Mode

Locate jumper JP2 (see *Figure 13 Configuration Jumper Locations*). To enable advanced mode set the jumper in the 8WX-16WX position.

NOTE:
Advanced operating mode is not supported in this release.

2.3.7 Configuring DIP Switches to Report Hardware Configuration

After all of the hardware configuration is complete DIP switches SW1 and SW2 must be used to report the information to the microcomputer. Each channel utilizes two switches that are coded in BCD (Binary Code Decimal) to report hardware configuration for that channel.

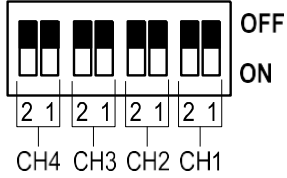
Channel N		BCD Value	Range Selected		
MSB Switch 2	LSB Switch 1				
OFF	OFF	0	Unipolar 5VDC		
OFF	ON	1	Unipolar 10 VDC		
ON	OFF	2	Bipolar -5 to +5VDC		
ON	ON	3	Bipolar -10 to +10VDC		

NOTE:
The OFF position is selected by actuating the switch in the direction of the center of the printed circuit board.

NOTE:
Standard shipping configuration is all switches in the OFF position Unipolar 5VDC range.

2.4 Inserting the Module into the I/O Base

Insert the module into the I/O base by carefully pushing the module into the slot. When the module is fully seated in the slot and backplane connector, tighten the captive screws at the top and bottom to hold the module in place. To remove the module from the I/O base, loosen the captive screws, then remove the module from the I/O base. Be careful not to damage the edge card at the back of the module when inserting or removing the module.

2.5 Wiring the Input Connectors

Input signals are accepted through a connector assembly located on the front of the module. The connector assembly consists of a standard Siemens® front panel edge connector that mates with the printed circuit board. Wiring is connected to the front connector via recessed screw terminals. The screw terminals can accept wire sizes up to single stranded 14gauge wire. The actual size wire used depends on the external device providing the input signal. Consult the device manufacturer’s recommendations for selecting the input wire size.

To assign an input to a specific channel, locate the appropriate channel position on the screw terminal connector as shown in the following figure:

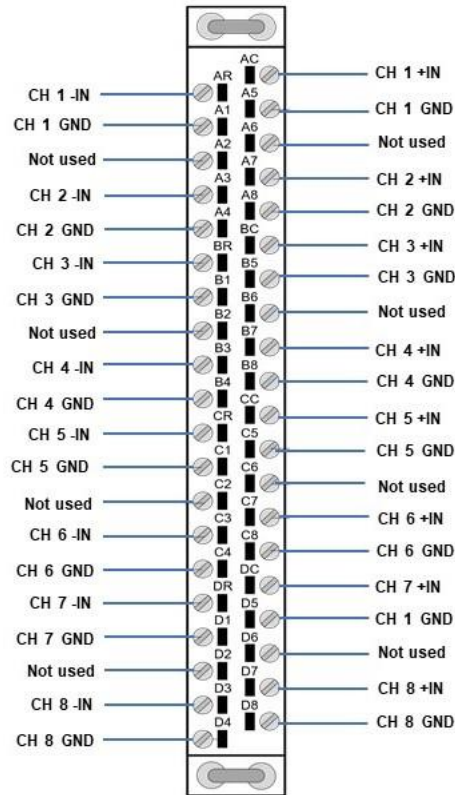

Figure 14 Screw Terminal Connector Wiring

2.5.1 Connecting Voltage Input Wiring

For voltage input circuits, connect the signal wire to the +IN (positive) screw terminal, and the return wire to the -IN (negative) screw terminal. Insert the wires in the appropriate holes on the front of the connector. When the wires are inserted, tighten the screws. Repeat this procedure for the remaining voltage input channels.

2.5.2 Connecting Current Input Wiring

For current input circuits, connect the signal wire to the +IN (positive) screw terminal, and the return wire to the -IN (negative) screw terminal. Insert the wires in the appropriate holes on the front of the connector. When the wires are inserted, tighten the screws. Repeat this procedure for the remaining current input channels.

2.5.3 Connecting the Shield Wiring

Control Technology Inc. recommends that all wires be shielded twisted pair with a foil wrap shield and a separate drain wire and that they be installed in a metallic conduit. Use Belden cable 8761 or equivalent which contains a foil wrap shield and a separate drain wire. The shield and the foil wrap should be twisted together and should be terminated at only one end. The other end should be left in an open circuit condition. CTI recommends that the shield be terminated at the PLC end of the signal wire. Special components are installed on the module to aid in the rejection of noise.

When entering the industrial cabinet the shield should be routed from the main terminal strip all the way to the PLC. Signal leads that do not maintain a shield from the terminal strip to the PLC act as antennas and are susceptible to radiated and conducted emissions in the cabinet. Unprotected cables may introduce measurement errors in the module.

The front connector on the module contains a G terminal which may be used for the shield wire if the installation is in a noise free environment. If the installation is in an extremely noisy environment CTI strongly recommends that the shielded wires terminated to the PLC chassis ground.

CTI has exhaustively tested this product to maximize its ability to reject noise from inductive sources as well as showering arcs, fast transients and other high frequency generators and has determined that the test best performance results from connecting all shield wires together at the PLC module and terminating this single wire to the chassis ground with a large current capacity conductor. CTI recommends using a #8 gauge wire are larger from the PLC chassis to the earth ground connection.

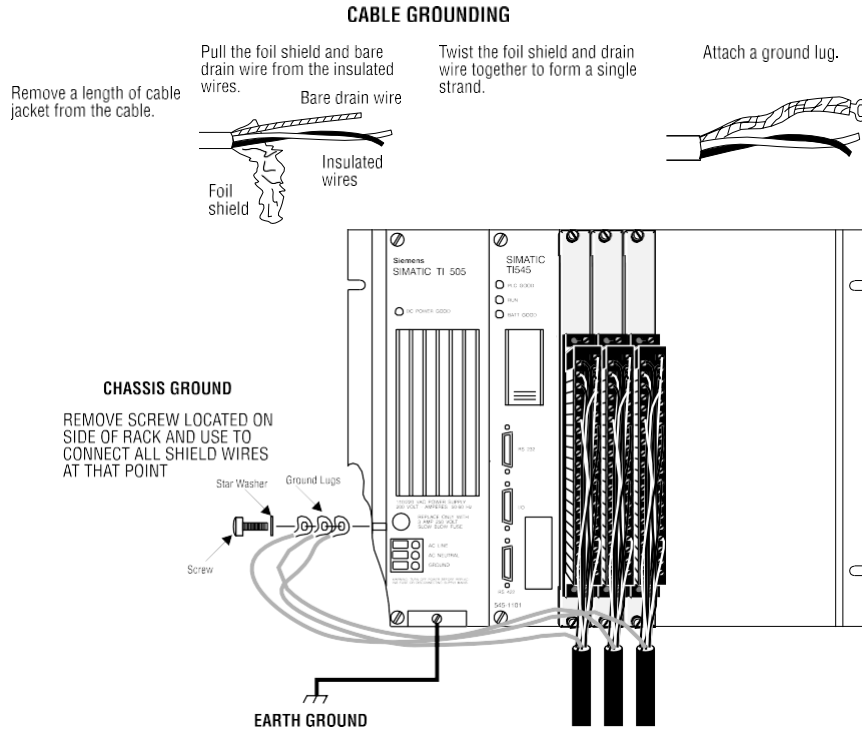

Figure 15 Shield Wire Termination

2.6 Installing the Screw Terminal Connector

When all the input signal wires are connected to the screw terminal connector, carefully install the connector on the front of the module.

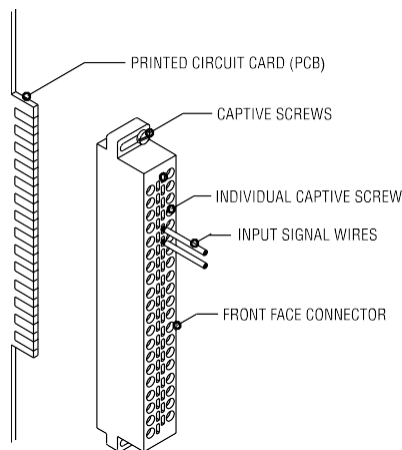

Figure 16 Input Connector Assembly

2.7 Checking Module Operation

First turn on the base power. If the module diagnostics detect no problems, the status indicator on the front of the module will light. If the status indicator does not light, begins blinking, (or goes out during operation), the module has detected a failure. For information on viewing failed module status, refer to your SIMATIC® TISOFT user manual. To diagnose and correct a module failure, refer to the next section on troubleshooting.

You must also check that the module is configured in the memory of the PLC. This is important because the module will appear to be functioning regardless of whether it is communicating with the PLC. To view the PLC memory configuration chart listing all slots on the base and the inputs or outputs associated with each slot, refer to your SIMATIC® TISOFT Programming Manual. An example chart is shown in the following figure.

```

I/O MODULE DEFINITION FOR CHANNEL ... 1  BASE ..... 00

      I/O  NUMBER OF BIT AND WORD I/O  SPECIAL
SLOT ADDRESS      X  Y  WX  WY  FUNCTION
01 ..... 0001 ..... 00 .. 00 .. 08 .. 00 ..... NO
02 ..... 0000 ..... 00 .. 00 .. 00 .. 00 ..... NO
      .
      .
15 ..... 0000 ..... 00 .. 00 .. 00 .. 00 ..... NO
16 ..... 0000 ..... 00 .. 00 .. 00 .. 00 ..... NO
  
```

Figure 17 Example I/O Configuration Chart

In this example, the Model 2550-A module is inserted in slot 1 in I/O base 0. Data for channel 1 appears in word location WX1, data for channel 2 appears in word location WX2, etc. For your particular module, look in the chart for the number corresponding to the slot occupied by the module. If word memory locations appear on this line, then the module is registered in the PLC memory and the module is ready for operation.

If the line is blank or erroneous, re-check the module to ensure that it is firmly seated in the slots. Generate the PLC memory configuration chart again. If the line is still incorrect, contact your local distributor or CTI at 1-800-537-8398 for further assistance.

NOTE:

*In the event a CTI analog detects an onboard module failure, the module will assert the module fail line and report the module failure in the I/O Status Word, which is reported to the PLC CPU. CTI strongly recommends the user application monitor the **I/O Module Status Words** which are Status Words 11-26 and apply to SIMATIC® Controllers 545, 555, 560 & 565 and the 575. The I/O Module Status Word can be used to report a module failure for an I/O Module in any of the 505 I/O slots. Please refer to Siemens® SIMATIC® 505 Programming Reference Manual for more information. If a module failure is reported by the status word, the module should be replaced with a working unit and the failed module sent in for repair.*

CHAPTER 3. TROUBLESHOOTING

If the module provides improper readings or the status indicator is not on, use the following chart to determine the appropriate corrective action.

SYMPTOM	PROBABLE CAUSE	CORRECTIVE ACTION
Indicator is not lit	Base or PC power is off Defective module	Turn base or PC on Return the module to CTI for repair
Indicator is blinking	Calibration data no longer stored in memory	Return the module to CTI for calibration
Incorrect inputs	Blown fuse	Return the module to CTI for repair
	Wrong addresses for word input	Check program for correct word input addresses
	Not logged-in	Read I/O configuration
	Incorrect jumper settings	Refer to Section 2.4 of this Installation & Operation guide for jumper settings
	Incorrectly calibrated	Return the module to CTI for recalibration
	Noisy signal	Check for proper shield termination at input connectors
	Offset scale enabled	If JP1 is enabled all inputs are scaled for 4-20mA offset operation

Figure 18 Troubleshooting Matrix

CAUTION:

The module fuse F1 is not user serviceable. If this fuse is blown, the module has a serious component failure and should be returned to CTI for repair.

When it is inconvenient to visually check the status indicator, use the TISOFT “Display Failed I/O” or “Show PLC Diagnostics” support functions.

If after consulting the chart above, you are unable to diagnose or solve the problem, contact your local distributor or CTI at 1-800-537-8398 for further assistance.

SPECIFICATIONS

Input Channels:

8 isolated analog input channels

Isolation: 1500VDC Channel-to-channel and
1500 VDC channel-to-PLC

Signal Range:

Unipolar : 0 to 5VDC, 0 to 10VDC or 0 to 20mA

Bipolar : -5 to +5VDC, -10 to +10VDC or -20 to +20mA

Update Time

8 WX mode: 4mSec all channels

Digital Filtering Time Constant: 0.3Sec

DC Input Resistance:

Voltage mode: 1MW

Current mode: 250W

Repeatability: 0.05%

Accuracy:

Voltage mode: 0.1% of full scale from 0-60°C

Current mode: 0.2% of full scale from 0-60°C

Resolution 8WX Mode:

Unipolar 12 bits pls sign:

0-5VDC range = 1.25 mV/step

0-10VDC range = 2.5 mV/step

0-20mA = 5 μ A/step

Bipolar 11 bits pls sign:

-5 to +5VDC range = 2.5 mV/step

-10 to +10VDC range = 5 mV/step

-20 to +20mA = 10 μ A/step

Common Mode Rejection:

>140db @ 60Hz

Normal Mode Rejection:

>40db @ 60Hz

Connector: standard CTI 2500-40F 40-position removeable connector, 14-22 AWG

Backplane Power: 6 Watts (maximum)

Module Size : Single-wide

Input ESD Protection : 20,000V

Overrange Protection : 500V

Shipping Weight : 1.5 lb. (0.68 Kg)

Specifications subject to change without notice.

JUMPER SETTINGS LOG SHEET

CHANNEL NUMBER	VOLTAGE CURRENT JUMPER	JUMPER POSITION V or I	VOLTAGE RANGE JUMPER	JUMPER POSITION 5V or 10V	UNIPOLAR/ BIPOLAR JUMPER	JUMPER POSITION
1	JP13		JP17		JP21	
2	JP14		JP18		JP22	
3	JP15		JP19		JP23	
4	JP16		JP20		JP24	
5	JP25		JP29		JP33	
6	JP26		JP30		JP34	
7	JP27		JP31		JP35	
8	JP28		JP32		JP36	

ALL CHANNELS	OFFSET SCALING JUMPER	JUMPER POSITION	DIGITAL FILTERING JUMPER	JUMPER POSITION	ADVANCED OPERATING MODE JUMPER	JUMPER POSITION
1 - 8	JP1		JP3		JP2	

Figure 19 Jumper Settings Log

Record the configuration jumper settings on this log for future reference. Make additional copies if necessary.

USER NOTES

LIMITED PRODUCT WARRANTY

CTI warrants that this CTI Industrial Product shall be free from defects in material and workmanship for a period of one (1) year after purchase from CTI or from an authorized CTI Industrial Distributor. This CTI Industrial Product will be newly manufactured from new and/or serviceable used parts which are equal to new in the Product.

Should this CTI Industrial Product fail to be free from defects in material and workmanship at any time during this one (1) year warranty period, CTI will repair or replace (at its option) parts or Products found to be defective and shipped prepaid by the customer to a designated CTI service location along with proof of purchase date and associated serial number. Repair parts and replacement Product furnished under this warranty will be on an exchange basis and will be either reconditioned or new. All exchanged parts or Products become the property of CTI. Should any Product or part returned to CTI hereunder be found by CTI to be without defect, CTI will return such Product or part to the customer.

This warranty does not include repair of damage to a part or the Product resulting from: failure to provide a suitable environment as specified in applicable Product specifications, or damage caused by an accident, disaster, acts of God, neglect, abuse, misuse, transportation, alterations, attachments, accessories, supplies, non-CTI parts, non-CTI repairs or activities, or to any damage whose proximate cause was utilities or utility like services, or faulty installation or maintenance done by someone other than CTI.

Control Technology Inc. reserves the right to make changes to the Product in order to improve reliability, function, or design in the pursuit of providing the best possible Product. CTI assumes no responsibility for indirect or consequential damages resulting from the use or application of this equipment.

THE WARRANTY SET FORTH ABOVE IN THIS ARTICLE IS THE ONLY WARRANTY CTI GRANTS AND IT IS IN LIEU OF ANY OTHER IMPLIED OR EXPRESSED GUARANTY OR WARRANTY ON CTI PRODUCTS, INCLUDING WITHOUT LIMITATION, ANY WARRANTY OF MERCHANTABILITY OR OF FITNESS FOR A PARTICULAR PURPOSE AND IS IN LIEU OF ALL OBLIGATIONS OR LIABILITY OF CTI FOR DAMAGES IN CONNECTION WITH LOSS, DELIVERY, USE OR PERFORMANCE OF CTI PRODUCTS OR INTERRUPTION OF BUSINESS, LOSS OF USE, REVENUE OR PROFIT. IN NO EVENT WILL CTI BE LIABLE FOR SPECIAL, INCIDENTAL, OR CONSEQUENTIAL DAMAGES.

SOME STATES DO NOT ALLOW THE EXCLUSION OR LIMITATION OF INCIDENTAL OR CONSEQUENTIAL DAMAGES FOR CONSUMER PRODUCTS, SO THE ABOVE LIMITATIONS OR EXCLUSIONS MAY NOT APPLY TO YOU.

THIS WARRANTY GIVES YOU SPECIFIC LEGAL RIGHTS, AND YOU MAY ALSO HAVE OTHER RIGHTS WHICH MAY VARY FROM STATE TO STATE.

REPAIR POLICY

In the event that the Product should fail during or after the warranty period, a Return Material Authorization number (RMA) can be requested verbally or in writing from CTI main offices. Whether this equipment is in or out of warranty, a Purchase Order number provided to CTI when requesting the RMA number will aid in expediting the repair process. The RMA number that is issued and your Purchase Order number should be referenced on the returning equipment's shipping documentation. Additionally, if under warranty, proof of purchase date and serial number must accompany the returned equipment. The current repair and/or exchange rates can be obtained by contacting CTI's main office at 1-800-537-8398.

When returning any module to CTI, follow proper static control precautions. Keep the module away from polyethylene products, polystyrene products and all other static producing materials. Packing the module in its original conductive bag is the preferred way to control static problems during shipment. **Failure to observe static control precautions may void the warranty.** For additional information on static control precautions, contact CTI's main office at 1-800-537-8398.