

**CTI 2554-A FOUR CHANNEL  
HIGH SPEED COUNTER MODULE  
INSTALLATION AND OPERATION GUIDE**

**Version 1.0  
CTI Part #062-00223**



**Copyright © 2005 Control Technology Inc.  
All rights reserved.**

This manual is published by Control Technology Inc., 5734 Middlebrook Pike, Knoxville, TN 37921. This manual contains references to brand and product names which are tradenames, trademarks, and/or registered trademarks of Control Technology Inc. Siemens® and SIMATIC® are registered trademarks of Siemens AG. Other references to brand and product names are tradenames, trademarks, and/or registered trademarks of their respective holders.

**DOCUMENT DISCLAIMER STATEMENT**

Every effort has been made to ensure the accuracy of this document; however, errors do occasionally occur. CTI provides this document on an "as is" basis and assumes no responsibility for direct or consequential damages resulting from the use of this document. This document is provided without express or implied warranty of any kind, including but not limited to the warranties of merchantability or fitness for a particular purpose. This document and the products it references are subject to change without notice. If you have a comment or discover an error, please call us toll-free at 1-800-537-8398.



---

## PREFACE

---

This *Installation and Operation Guide* provides installation and operation instructions for the CTI Model 2554-A Four-Channel High Speed Counter Module for SIMATIC® 505 programmable controllers. We assume you are familiar with the operation of SIMATIC® 505 Series programmable controllers. Refer to the appropriate SIMATIC® user documentation for specific information on the SIMATIC® 505 programmable controllers and I/O modules.

This *Installation and Operation Guide* is organized as follows:

Chapter 1 provides a general description of the module and operating modes.

Chapter 2 covers Mode 3 (General Counter Mode) operation.

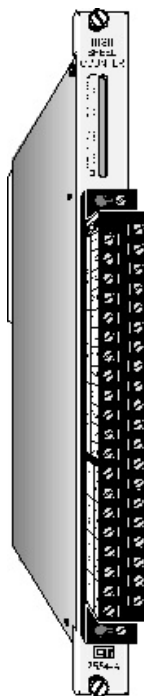
Chapter 3 covers installation and wiring.

Chapter 4 covers module configuration.

Chapter 5 is a PLC programming example.

Chapter 6 is a guide to troubleshooting.

Chapter 7 covers Quadrature Mode operation.



**Figure 1** *The Model 2554-A Four-Channel High Speed Counter Module*



---

## USAGE CONVENTIONS

---

**NOTE:**

*Notes alert the user to special features or procedures.*

**CAUTION:**

*Cautions alert the user to procedures which could damage equipment.*

**WARNING:**

*Warnings alert the user to procedures which could damage equipment and endanger the user.*

**WARNING:**

*The CTI Model 2554-A High Speed Counter controls its four discrete outputs. If the PLC is switched from RUN mode to PROGRAM mode the module will continue to function as programmed and the outputs may be activated by the module.*





---

## TABLE OF CONTENTS

---

PREFACE.....	v
USAGE CONVENTIONS.....	vii
TABLE OF FIGURES.....	xi
CHAPTER 1. DESCRIPTION.....	1
1.1 Theory of Operation.....	1
1.2 Mode 0 - Period Measurement (microseconds).....	2
1.3 Mode 1 - Period Measurement (Hz).....	2
1.4 Mode 2 - Frequency Measurement (Hz).....	2
1.5 Mode 3 - Event Counter.....	2
1.6 Quadrature Counter Mode.....	2
1.7 Compatibility with Immediate I/O.....	2
1.8 Front Panel Description.....	3
CHAPTER 2. MODE 3 OPERATION.....	5
2.1 Control Word.....	5
2.1.1 Loading Preset Values.....	7
2.2 Status Word.....	8
2.3 Preset Target Values.....	9
2.4 Automatic Reset.....	9
2.4.1 Minimum Preset Target Values With Automatic Reset.....	10
2.5 Output Control.....	11
2.6 Gating and Reset.....	11
CHAPTER 3. INSTALLATION.....	13
3.1 Planning the Installation.....	13
3.1.1 Calculating the I/O Base Power Budget.....	13
3.2 Unpacking the Module.....	13
3.3 Inserting the Module into the I/O Base.....	14
3.4 Wiring the Input Connector.....	14
3.4.1 Connecting the Shield Wiring.....	15
3.4.2 Connecting to the Counter Inputs.....	16
3.4.3 Connecting I/O Wiring.....	17
3.4.4 Wiring the Gate Inputs.....	18
3.4.5 Wiring the Reset Input.....	18
3.4.6 Wiring the Outputs.....	19
3.5 Checking Module Operation.....	20
CHAPTER 4. CONFIGURING THE MODULE.....	21
4.1 Selecting Counter Mode or Quadrature Mode.....	22
4.2 Input Signal Conditioning.....	23
4.3 Mode Select Switches and Jumpers.....	24
4.4 Gate, Reset, and Output Jumpers.....	26

CHAPTER 5. PLC Programming Example. ....	29
5.1 A Programming Example. ....	29
CHAPTER 6. TROUBLESHOOTING.....	35
CHAPTER 7. Quadrature Operation. ....	37
7.1 Quadrature Mode Operation.....	37
7.2 Quadrature Data Presentation.....	38
7.3 Wiring for Quadrature Mode Operation.....	38
SPECIFICATIONS. ....	41
LIMITED PRODUCT WARRANTY .....	43
REPAIR POLICY. ....	45

---

## TABLE OF FIGURES

---

<b>Figure 1</b> <i>The Model 2554-A Four-Channel High Speed Counter Module.</i> . . . . .	v
<b>Figure 2</b> <i>Module PLC Interface.</i> . . . . .	1
<b>Figure 3</b> <i>Front Panel Description.</i> . . . . .	3
<b>Figure 4</b> <i>Bit Number Assignments.</i> . . . . .	5
<b>Figure 5</b> <i>Control Word Bit Assignments.</i> . . . . .	6
<b>Figure 6</b> <i>Loading Preset Values.</i> . . . . .	7
<b>Figure 7</b> <i>Selecting Input Channel for Target Presets.</i> . . . . .	7
<b>Figure 8</b> <i>Status Word Bit Assignments.</i> . . . . .	8
<b>Figure 9</b> <i>Minimum Preset Target Value vs. PLC Scan Time</i> . . . . .	10
<b>Figure 10</b> <i>Shield Wire Termination.</i> . . . . .	15
<b>Figure 11</b> <i>(AC) Sine Wave Counter Inputs.</i> . . . . .	16
<b>Figure 12</b> <i>TTL Counter Inputs (Negative Transition).</i> . . . . .	16
<b>Figure 13</b> <i>TTL Counter Inputs (Positive Transition).</i> . . . . .	16
<b>Figure 14</b> <i>Open Collector Counter Inputs.</i> . . . . .	17
<b>Figure 15</b> <i>Model 2554-A Wiring Connector.</i> . . . . .	17
<b>Figure 16</b> <i>TTL Sourcing Application.</i> . . . . .	18
<b>Figure 17</b> <i>Open Collector Sinking Application.</i> . . . . .	18
<b>Figure 18</b> <i>Wiring the Outputs.</i> . . . . .	19
<b>Figure 19</b> <i>Model 2554-A I/O Configuration Chart.</i> . . . . .	20
<b>Figure 20</b> <i>Model 2554-A Counter Mode or Quadrature Mode Jumpers.</i> . . . . .	22
<b>Figure 21</b> <i>Model 2554-A Input Signal Conditioning Jumpers.</i> . . . . .	23
<b>Figure 22</b> <i>Model 2554-A Mode Jumpers.</i> . . . . .	24
<b>Figure 23</b> <i>SW1 and SW2 Settings.</i> . . . . .	25
<b>Figure 24</b> <i>Model 2554-A Gate, Reset, and Output Jumpers.</i> . . . . .	26
<b>Figure 25</b> <i>Model 2554-A Default Shipping Configuration.</i> . . . . .	27
<b>Figure 26</b> <i>Reset and Disable Input Counter Channels.</i> . . . . .	29
<b>Figure 27</b> <i>Control Word for Sample Application.</i> . . . . .	30
<b>Figure 28</b> <i>Loading Preset Values for Channel 1.</i> . . . . .	32
<b>Figure 29</b> <i>PLC Interface.</i> . . . . .	38
<b>Figure 30</b> <i>Quadrature Increment.</i> . . . . .	38
<b>Figure 31</b> <i>Quadrature Decrement.</i> . . . . .	38
<b>Figure 32</b> <i>Quadrature Wiring Example.</i> . . . . .	39



---

## CHAPTER 1. DESCRIPTION

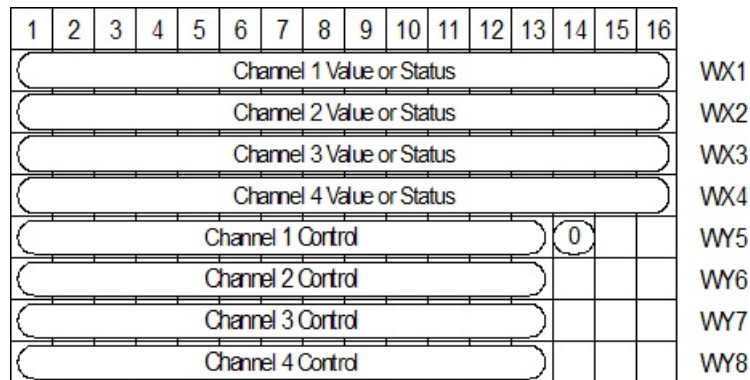
---

The Model 2554-A Four-Channel High Speed Counter Module is a member of Control Technology's family of I/O modules compatible with the SIMATIC® 505 Series programmable controllers.

### 1.1 Theory of Operation

The Model 2554-A High Speed Counter provides four channels which are designed to count input pulses and translate them into an equivalent digital word. There are several different counting modes which can be chosen on a per-channel basis. The module operates asynchronously with respect to the PLC, i.e. a PLC scan and the module's input sampling are concurrent. The Model 2554-A translates all counter inputs in one module update and stores the translated words in a buffer which the PLC retrieves at the start of an I/O scan. To provide tight control in applications where this delay is critical, the Model 2554-A can actuate its outputs based on preset counter values and auto-reset such as that no input pulses are missed.

Each input channel utilizes a control word WY and a status word WX to interact with the PLC ladder logic. These interfaces are only used in Mode 3 operation. The control word allows the PLC to start, stop, configure, and reset the counter channel. Status information such as counter overflow or if a preset value has been reached is provided to the PLC via the status word. The module logs into the PLC as 4WX and 4WY registers. The WX registers return either data or status depending on whether enabled in the control word.



**Figure 2** Module PLC Interface

For Modes 0, 1, and 2 (everything except Mode 3), the WY control word for the respective channel should be 0. This will enable the WX data/status word to report data to the PLC. An 8 in the WY control word will send status back in the associated WX word. (The status will report the mode which the channel's jumpers/dip switches are set for, i.e. either a 0, 1, or 2.) Refer to Sections 2.1 and 2.2 for a complete discussion of Control and Status words.

### ***1.2 Mode 0 - Period Measurement (microseconds)***

The period measurement mode provides good accuracy at low frequencies by counting the number of internal clock cycles between external input pulses. The internal clock is generated by a 1 MHz crystal oscillator. The data is reported to the PLC as microseconds and represents the period of the input signal. 17 Hz is the lowest frequency measurable. The accuracy of Mode 0 decreases as frequency increases. Update time of period mode is 100 milliseconds.

### ***1.3 Mode 1 - Period Measurement (Hz)***

Mode 1 operates the same as Mode 0 except that the data is reported as Hertz and represents the frequency of the input signal.

### ***1.4 Mode 2 - Frequency Measurement (Hz)***

For high frequencies (up to 65 kHz input limit), Mode 2 is a better choice than Modes 0 and 1. In frequency measurement mode, the Model 2554-A counts the number of external input pulses between internal clock cycles. The internal clock in this mode runs a 1 Hz, therefore the update time of frequency mode is 1 second. Data is reported to the PLC as Hertz.

### ***1.5 Mode 3 - Event Counter***

This is the general counter mode which allows absolute counting of input pulses. The current value of the counter is updated into the buffer once per PLC scan. See Chapter 2 for a detailed description of Mode 3.

### ***1.6 Quadrature Counter Mode***

The module can also be configured to operate in Quadrature Mode. Modes 0 through 3 are selectable on a per-channel basis, but Quadrature Mode requires all four channels. Quadrature Mode examines the phase relationship between two inputs, A and B. If A leads B, the counter will count up. If B leads A, the counter counts down. This form of operation is useful for incremental encoders.

Channels 1 and 2 correspond to inputs A and B for Quadrature Channel 1. Channels 3 and 4 are A and B for Quadrature Channel 2. The limitation on counting is +32,767 to -32,767.

### ***1.7 Compatibility with Immediate I/O***

The Model 2554-A has been tested and is compatible with the Immediate read function of the SIMATIC® 545 and 555 PLC.

## Front Panel Description



**Figure 3** *Front Panel Description*

### **ACT**

The Active LED signifies a normally functioning module. If this is not lit, refer to the Chapter 6 Troubleshooting section.

### **GATE**

There is a Gate LED for each channel which indicates the state of the external gate input. This will illuminate when a signal greater than a TTL high level is present on the gate input terminal for that channel. If external gating is selected (see Sections 2.4 and 4.4), the associated channel counter will be enabled.

### **RESET**

Each channel also has a Reset LED which indicates the state of the external reset input. If the external level reset is selected (see Sections 2.4 and 4.4), the channel will not count (it is continually reset) as long as the reset signal is greater than a TTL high level. If external edge reset is selected, the channel counter will reset to zero when the signal exceeds a TTL high level and then resume counting even though the LED may still be illuminated.

### **OUT**

The Output LEDs report the state of the channel output circuit. This is the field side of the output, not the logic side.

### **PULSE**

The Pulse LED will be illuminated when there is a signal present on the logic side of the associated input. This LED is dependent on the signal conditioning selected (negative, positive, or bipolar). Refer to Section 4.2.

### **BF**

The Blown Fuse LED will turn on if there is a blown fuse in any of the output circuits. This LED is common to all four channels. The replacement fuse type is listed in the module specifications in the back of this manual.





---

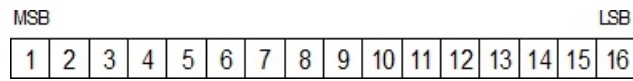
## CHAPTER 2. MODE 3 OPERATION

---

### 2.1 Control Word

The PLC ladder program maintains control over each input channel with a WY register control word. This word is used to load presets, reset the counter, stop the counter and enable the discrete outputs. The WY words, e.g. WY5, WY6, WY7, WY8, from the PLC to the module are control words which program the various options, such as preset values, auto reset, output enable, etc:

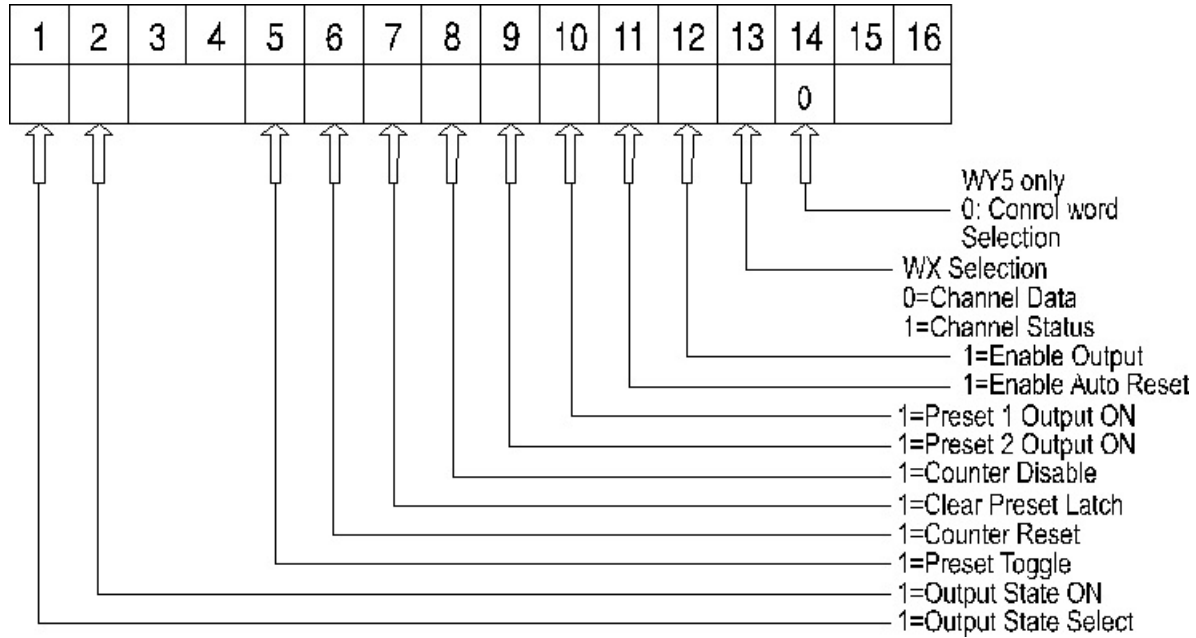
The 16-bit word is in the following format:



**Figure 4** *Bit Number Assignments*

**NOTE:**

*Some control word bits are level-sensitive where others are edge-sensitive. An edge-sensitive bit is only effective on a 0-to-1 transition; a constant 0 or 1 or a transition from 1-to-0 does not cause any action to take place. Where a bit is edge-sensitive it will be denoted, otherwise it is level-sensitive.*



**Figure 5** Control Word Bit Assignments

**NOTE:**  
*The only edge-sensitive bits are bit 1 (turn output on or off), bit 6 (internal reset), and bit 7 (clear preset status latch).*

**NOTE:**  
*Bit 5 is only looked at when a reset signal is active. It must be present before an edge-triggered reset comes active. You do not want to use this bit if the external reset is level-triggered because the preset will get toggled continuously with no user control over its final state when the reset signal is removed.*

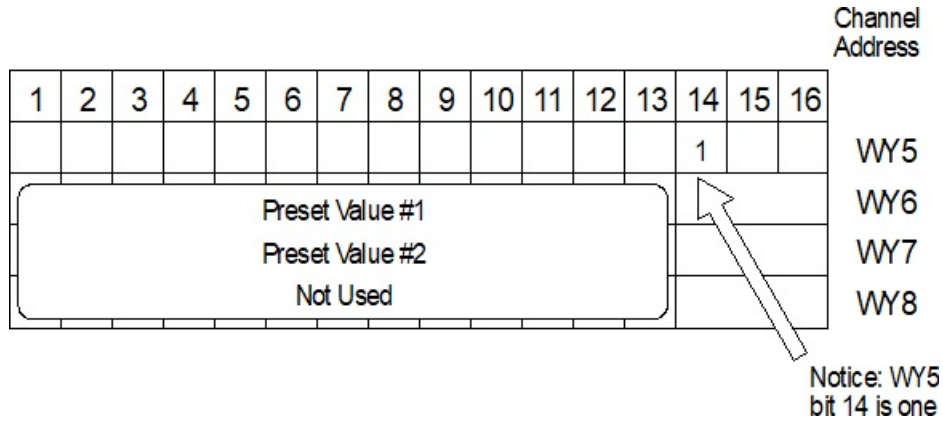
### 2.1.1 Loading Preset Values

Preset values are loaded for each channel by setting WY5:14 and addressing the specific channel with WY5:15 and WY5:16.

#### WY5:14

Bit 14 of WY5 determines the meaning of the other WY words:

If **bit 14 is a 1**, then WY6 and WY7 contain the preset values 1 and 2 for the channel number designated by bits 15 and 16:



**Figure 6** Loading Preset Values

If bit 14 is a 0, then WY5 through WY8 are control words for channels 1 through 4, respectively. In this case, bits 15 and 16 have no meaning.

**NOTE:**  
*If bit WY5:14 is a 1, the module ignores all other bits in WY5, and the whole WY8 word.*

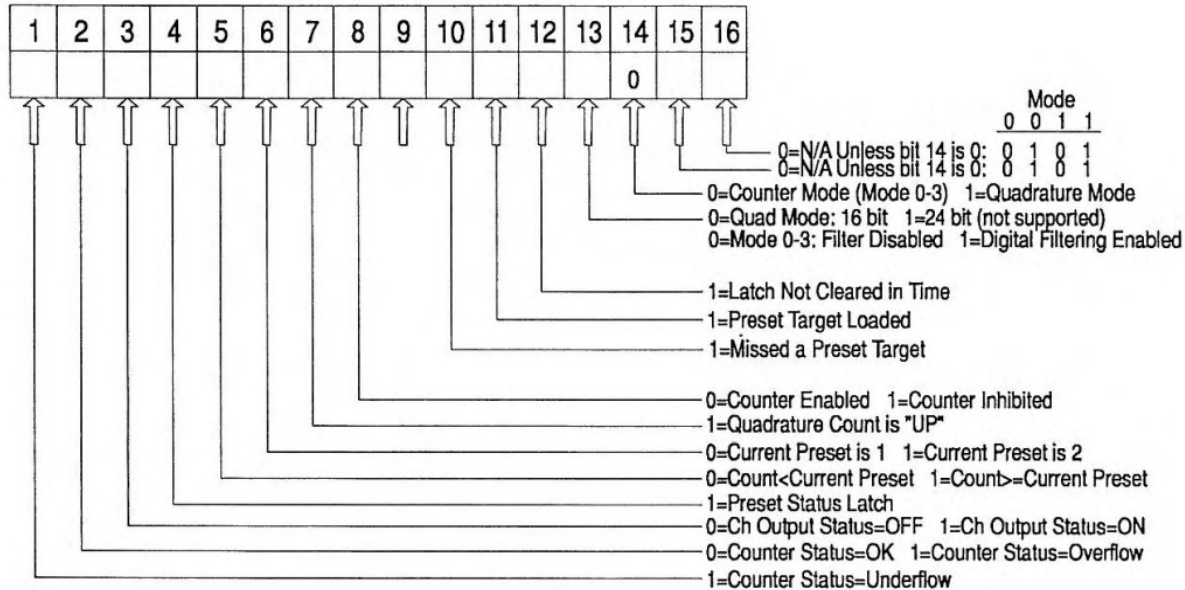
The following figure illustrates channel addressing with bits WY5:15 and WY5:16.

	WY5:14	WY5:15	WY5:16
Channel 1	1	0	0
Channel 2	1	0	1
Channel 3	1	1	0
Channel 4	1	1	1

**Figure 7** Selecting Input Channel for Target Presets

## 2.2 Status Word

Under normal operation the count value is returned in the WX register for each input channel. When enabled a status word is reported. By setting WY:13 to a 1 (assuming WY5:14 is a 0), each channel can report status to the PLC instead of its current counter value. The first WX word (WX1 in this manual) corresponds to channel 1, and so on. The status word is used to detect that an input channel reached a preset value, or if an overflow condition has occurred. The status bit definitions are :



**Figure 8 Status Word Bit Assignments**

**Bit 1** is the underflow flag. In Quadrature Mode a count <-32767 has been detected.

**Bit 2** is the counter status: 0 indicates a count <65535, 1 indicates an overflow condition.

**Bit 3** reflects the true output state. It will be zero if the output is disabled (WY:12=0) or the hardware jumper is on "output disable" even if logic is commanding the channel to be on.

**Bit 4** indicates that a preset has been reached when the channel is in auto-reset mode. This bit must be reset from the control word (WY:7).

**Bit 5** shows where the counter is with respect to the preset target.

**Bit 6** indicates which preset is the current target (the preset value which the microprocessor is comparing the counter value against).

**Bit 7** indicates the direction for counting in Quadrature Mode, 1 indicates upward count.

**Bit 8** is a 1 if the counter is inhibited by either the internal or external gate signal.

**Bit 9** not used.

**Bit 10** indicates that a preset target value has been missed by the counter.

**Bit 11** indicates that a preset target value is loaded for the channel. This bit can be examined after loading presets at start up to verify download procedure.

**Bit 12** indicates that the preset latch bit was not cleared by the PLC ladder logic before another preset condition was reached. This bit is cleared by the control word WY:7.

**Bit 13** definition depends on bit 14. If in quadrature mode, it represents the maximum count. If in counter mode (Modes 0, 1, 2, or 3) it represents the status of the digital filter.

**Bit 14** is only used in Quadrature Mode. 1 indicates module is configured for Quadrature operation.

**Bits 15 and 16** also depend on bit 14. If it is 0 (counter mode), then they indicate which variety of counter mode. They return the counter mode, i.e 0, 1, 2 or 3.

### 2.3 Preset Target Values

Each channel can have up to two preset values. These are loaded to the module from the PLC using the control words WY5/6/7/8. (In this manual we assume the WX words to be 1 through 4, and WY words to be 5 through 8. This is, of course, dependent on your own addressing assignments. When we talk about bit addresses we will use a shorthand form, e.g. WY:13. This refers to bit 13 of any WY word. Likewise WY5:14 refers to bit 14 of WY5.) In its basic operation the counter will count to a preset then turn on the output associated with that channel.

The presets can be downloaded to the module at anytime, but care must be taken if doing this dynamically (while the module is counting). The module will load a new preset value even if it is currently comparing against it, but will not turn on the output if the current count already exceeds the new preset. For example, if preset 1 is 20 and the counter is at 15 when a new preset 1 value of 10 is loaded, the counter will not turn on the output or any status bits even though the count exceeds preset. The counter will continue to its maximum value. If, however, the new preset value is 25, then the output will be turned on when the counter equals 25. By monitoring bits in the WX status words the user can determine which preset value is currently being used, where the counter is in relation to the presets, and the state of the channel output. (See WY:13 and WX:3/4/5/6 for details.)

**NOTE:**

*If presets are not used, the module will count freely to its maximum value of FFFF hex (65535 decimal). At that point it will turn on the channel output, set the **counter overflow (WX:2)** status bit, then go to zero and remain there until reset. The output stays on.*

**NOTE:**

*If only one preset value is used, it must be preset 1 and preset 2 must be zero. When both presets are used, the counter first counts from zero to preset 1, then turns on the channel output. What happens next depends on automatic reset.*

### 2.4 Automatic Reset

Applications that must count input pulses without missing a count use automatic reset. This mode guarantees that an input pulse is not missed provided the input frequency and the preset target value fall within the operating limits of the module. These types of applications count to a preset target value and count in relay ladder logic the number of times the preset value is reached. Automatic reset is enabled with control word WY:11. Once a preset target is reached, the counter sets WX:4 (preset status latch) and looks for the next input pulse.

If the **automatic reset (WY:11)** is not enabled, the counter continues past preset 1 until it gets a reset command, either internally or externally. This reset command sets the counter to zero and turns off the channel output. If automatic reset is enabled, the module resets the counter (but not the output), sets the **latched preset status bit (WX:4)** and then begins counting to preset 1 again. If preset 2 is present (not equal to zero) the counter begins counting to the value of preset 2. When the counter value equals preset 2, the module again commands the output to go on, resets the counter to zero and begins counting to preset 1 again, and so on. Auto reset ensures that the counter does not miss any input impulses while waiting for the PLC or an external action to reset the counter. The maximum input frequency that auto reset can handle is 50 kHz; this is the aggregate sum for all the channels.

**NOTE:**

*It is recommended that any channels not being used in a Mode 3 application be set to some other mode to relieve the microprocessor of continually checking for pulses.*

The latched preset status bit (WX:4) is only active in auto reset mode, and it can only be read if the WX word is returning status, not data (see WY:13). Once either preset has been reached and this bit is set, it must be reset (see WY:7) before it can be set again. The latched preset bit is useful in applications where a running count is being kept in the PLC of how many times the counter has reached the preset value(s).

**2.4.1 Minimum Preset Target Values With Automatic Reset**

In automatic reset mode the 2554-A signals the PLC that a preset condition has been met by asserting the WX:4 preset status latch. In return the PLC ladder program must clear this latch with WY:7. It is this handshaking procedure that is dependent upon a PLC ladder scan time that limits the minimum preset target value for each channel.

The following table further illustrates this dependency for a 1000 Hz input.

PLC SCAN TIME	MINIMUM PRESET VALUE
10 mSec	50
20 mSec	100
30 mSec	150
40 mSec	200
50 mSec	250

**Figure 9** Minimum Preset Target Value vs. PLC Scan Time

**NOTE:**

*Selecting a preset value less than a minimum recommended value may cause erratic unpredictable behavior with WY:7 and WX:4.*

## 2.5 Output Control

As previously described under Presets, when a counter reaches a preset value it turns that channel's output on. However, there are some options which can be specified.

Each channel has a **master enable bit (WY:12)** for its output. If this bit is not set the output will never come on. This is a safety feature since the PLC does not directly control the module's outputs. It is possible for the PLC to be in a mode where its outputs are supposed to be disabled (e.g. program mode). The module may still be counting pulses and could turn an output on regardless of what the PLC thinks. This bit is an insurance against that occurrence. As an additional level of safety, the hardware jumper (JP105-107 and etc. for the other channels) must be set to either "normal output" (TRUE logic) or "inverted output" (FALSE logic). If the jumper is on "outside disable", the output will not come on no matter what the control words say. Refer to Section 4.4.

Each preset has the option of turning its associated channel output on or off when it is equal to the counter value using the **preset output state bits (WY:9/10)**. Using this capability. Preset 1 could turn the output on, then preset 2 could turn it off.

The user can also command the output to turn on (or off) from the PLC regardless of the state of the counter through the **output command bit (WY:1)**. This is an edge-sensitive signal so it will only cause an output change on the PLC scan in which the transition from 0 to 1 is sent to the module. Subsequent scans where its value does not change, or when it goes back to a 0 level, will not change the state of the output. By setting the **output state bit (WY:2)**, the user chooses whether the output goes on or off. The output state bit also determines the state of the output when commanded to reset (see **Gating and Reset** below). When the counter turns an output on (counter=preset), the user most often will need to detect that condition either through the **output status bit (WX:3)** or by bringing the output back in through a discrete module. There are many ways to turn this output off: have preset 2 turn it off (WY:9=0), reset the channel externally or internally (WY:6=0-to-1 transition), or reset the output using the output control bit (WY:1=0-to-1 transition).

## 2.6 Gating and Reset

Each channel has a gate which must be enabled to allow the channel to count. This gate may be an internal or external signal. The **internal gate (WY:8)** is a low-active level-sensitive signal, as long as the bit is zero, the counter will count. [The internal gate is low-active so the default WY condition (PLC sends all 0s) will allow the counter to count.] The external gate signal is also level-sensitive, but it is high-active. If the gate is disabled the count will hold at its current value (unless it gets a reset signal), and a subsequent gate enable will resume counting at the held value.

The reset signal for each channel resets both the channel output and the counter (as opposed to auto reset which only resets the counter value). The counter reset will always force the counter to zero, but when counting resumes the compare can be either against the current preset or it can toggle to the other preset value. The **preset target bit (WY:5)** determines this option. If the preset target is to be toggled on reset, this bit must be set before the internal reset signal comes active. This is because the internal reset is an edge-triggered signal and the dependent condition must already be established in the microprocessor when the actuating signal comes active. External reset, whether level or edge-triggered, is asynchronous to the PLC scan so there is no way to specify the setup time. To know which preset the counter will resume comparing against, the user may read the preset status bit which the module can send to the PLC (see WX:6 and WY:13).

The internal/external reset of the channel output will turn the output on or off depending on which state is specified by the user (see WY:2). The **internal reset (WY:6)** is edge-sensitive. The external reset can be specified via jumpers to be either edge-sensitive (rising edge) or level-sensitive (high-active). Refer to Section 4.4.

***NOTE:***

*The jumper settings JP100-400 which refer to the internal/external reset do not disable the internal reset capability. They can only enable the external reset signals (by choosing edge or level-triggering). Internal reset is always available through the WY control words.*



---

## CHAPTER 3. INSTALLATION

---

The installation of the Four-Channel High Speed Counter Module involves the following steps:

1. Planning the installation
2. Configuring the module (see Chapter 4)
3. Inserting the module into the I/O base
4. Wiring and connecting the module input connector
5. Checking module operation

The steps listed above are explained in detail in the following pages.

### *3.1 Planning the Installation*

Planning is the first step in the installation of the module. This involves calculating the I/O base power budget and routing the input and output signal wiring to minimize noise. The following sections discuss these important considerations.

#### *3.1.1 Calculating the I/O Base Power Budget*

The Model 2554-A requires 4.0 watts of +5VDC power from the I/O base. Use this value to verify that the base power supply capacity is not exceeded.

### *3.2 Unpacking the Module*

**NOTE:**

*The components on the Model 2554-A module printed circuit card can be damaged by static electricity discharge. To prevent this damage, the module is shipped in a special anti-static bag. Static control precautions should be followed when removing the module from the bag, when operating the module, and when handling the printed circuit card during configuration.*

Open the shipping carton and remove the special anti-static bag which contains the module.

After discharging any static buildup, remove the module from the static bag. **Do not discard the static bag. Always use this bag for protection against static damage when the module is not inserted into the I/O backplane.**

### ***3.3 Inserting the Module into the I/O Base***

Insert the module into the I/O base by carefully pushing the module into the slot. When the module is fully seated in the slot and backplane connector, tighten the captive screws at the top and bottom to hold the module in place. To remove the module from the I/O base, loosen the captive screws, then remove the module from the I/O base.

### ***3.4 Wiring the Input Connector***

Input connections are accepted through a connector assembly located on the front of the module. The connector assembly consists of a standard Siemens® edge connector with captive screws and wiring receptacles accessible from the front of the module.

Note the following general considerations when wiring the module:

Always use the shortest possible cables.

Avoid placing low voltage wire parallel to high energy wire (if the two wires must meet, cross them at a right angle).

Avoid bending the wire into sharp angles.

Use wireways for wire routing.

Avoid placing wires on any vibrating surface.

Input signal wiring for the counter inputs must be shielded twisted-pair cable. The shielding for the cable should always be terminated to chassis ground. Standard wiring practices usually require that all shields be tied together and grounded at a single point. This will provide the best performance. There should never be any shield termination at the source end of the signal wire.

***NOTE:***

*Input signal wiring for the four counter inputs must be shielded twisted-pair cable. The shielding should always be terminated to the chassis ground.*

### 3.4.1 Connecting the Shield Wiring

Control Technology Inc. recommends that all wires be shielded twisted pair with a foil wrap shield and a separate drain wire and that they be installed in a metallic conduit. Use Belden cable 8761 or equivalent which contains a foil wrap shield and a separate drain wire. The shield and the foil wrap should be twisted together and should be terminated at only one end. The other end should be left in an open circuit condition. CTI recommends that the shield be terminated at the PLC end of the signal wire. Special components are installed on the module to aid in the rejection of noise.

When entering the industrial cabinet the shield wires should be routed from the main terminal strip all the way to the PLC. Signal leads that do not maintain a shield from the terminal strip to the PLC act as antennas and are susceptible to radiated and conducted emissions in the cabinet. Unprotected cables may introduce measurement errors in the module.

The front connector on the module contains a G terminal which may be used for shield wire if the installation is in a noise free environment. If the installation is in an extremely noisy environment CTI strongly recommends that the shielded wires be terminated to the PLC chassis ground.

CTI has exhaustively tested this product to maximize its ability to reject noise from inductive sources as well as showering arcs, fast transients and other high frequency generators and has determined that the best performance results from connecting all shield wires together at the PLC module and terminating this single wire to the chassis ground with a large current capacity conductor. The PLC chassis should then be wired to earth ground with a large current capacity conductor. CTI recommends using a #8 gauge wire or larger from the PLC chassis to the earth ground connection.

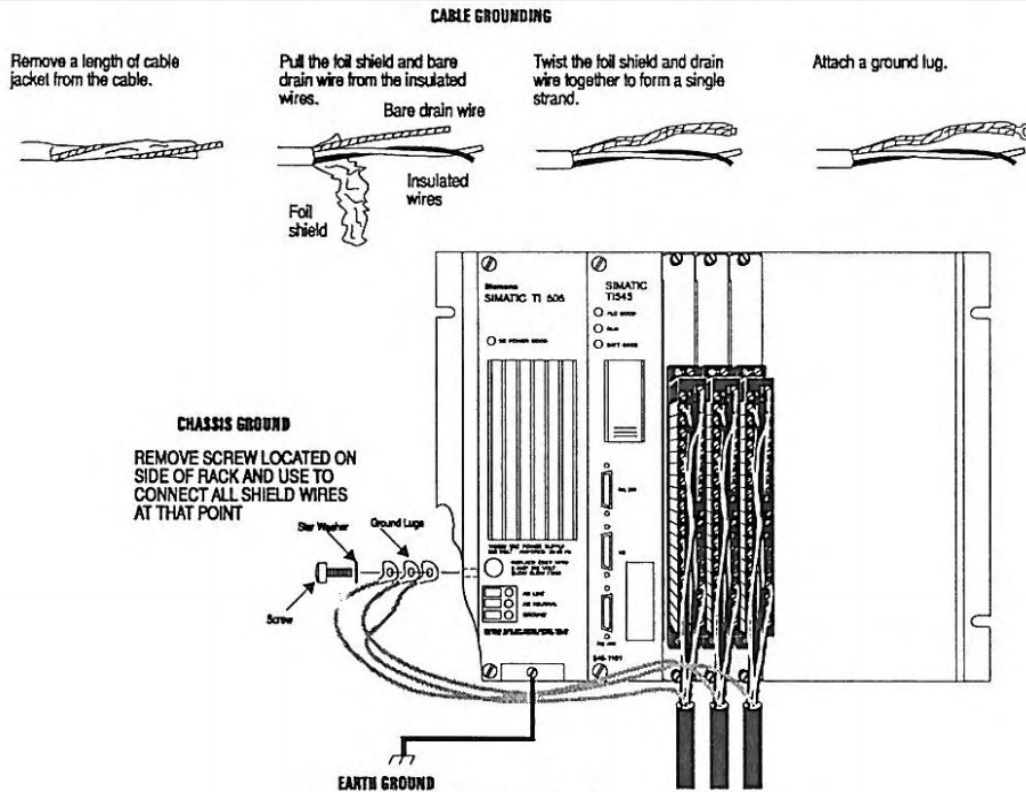
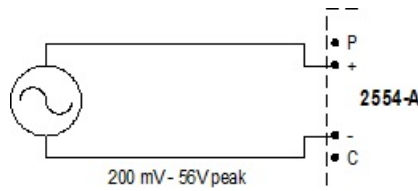


Figure 10 Shield Wire Termination

### 3.4.2 Connecting to the Counter Inputs

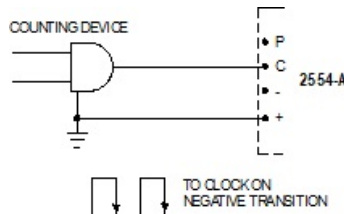
For (AC) sine wave counter inputs:



**Figure 11** (AC) Sine Wave Counter Inputs

- A. Wire counter "+" wire to "+" terminal
- B. Wire counter "-" wire to "-" terminal
- C. Wire Shield wire, if present, to external chassis ground
- D. "P" terminal is not used

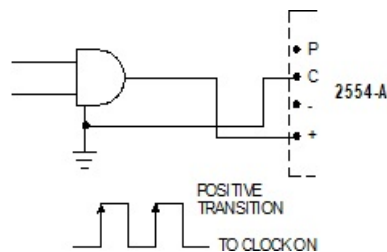
For TTL counter inputs and to clock on a negative transition:



**Figure 12** TTL Counter Inputs (Negative Transition)

- A. Wire counter "+" wire to "C" terminal
- B. Wire counter "-" wire to "+" terminal
- C. Wire Shield wire, if present, to external chassis ground
- D. "P" and "-" terminals not used

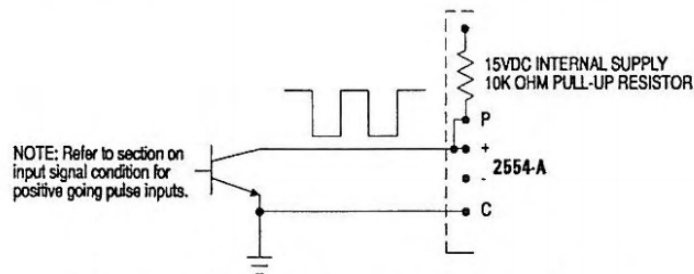
For TTL counter inputs and to clock on positive transition:



**Figure 13** TTL Counter Inputs (Positive Transition)

- A. Wire counter "+" wire to "+" terminal
- B. Wire counter "-" wire to "C" terminal
- C. Wire Shield wire, if present, to external chassis ground
- D. "P" and "-" terminals not used

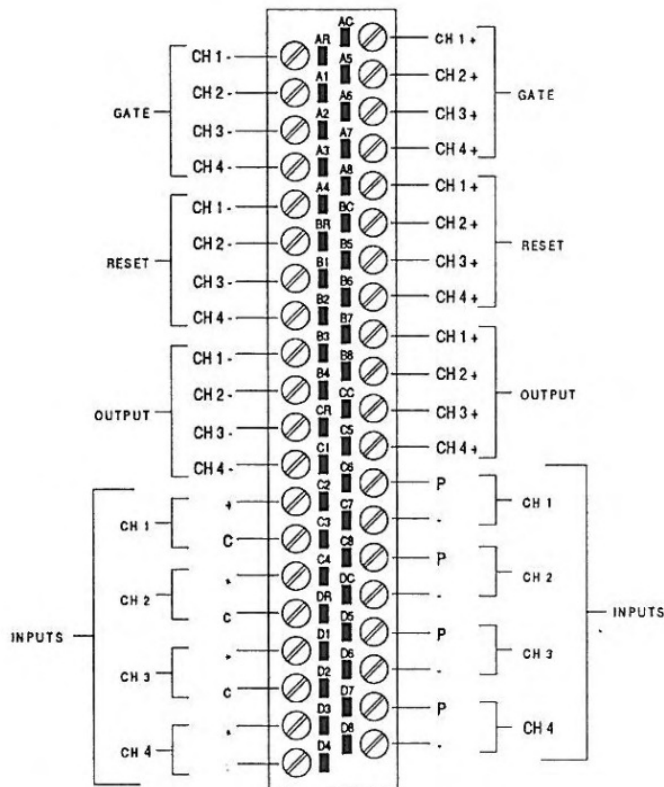
For Open Collector counter inputs:



**Figure 14** Open Collector Counter Inputs

- A. Wire counter "Emitter" wire to "C" terminal
- B. Wire counter "Collector" wire to "+" terminal
- C. Jumper "P" terminal on 2554-A to "+" terminal
- D. "-" terminal is not used
- E. Wire Shield wire, if present, to external chassis ground

### 3.4.3 Connecting I/O Wiring



**Figure 15** Model 2554-A Wiring Connector

### 3.4.4 Wiring the Gate Inputs:

Before wiring an external device to the gate input ensure that the configuration jumpers JP100, 200, 300, and 400 are set for external gate operation. Wire the positive terminal of the controlling device to the (+) input on the Model 2554-A connector for the appropriate channel and the negative wire to the negative terminal.

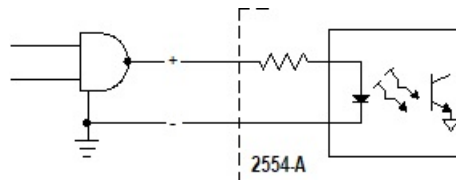
### 3.4.5 Wiring the Reset Input:

External resets may be either level or edge-sensitive. A level reset holds the counter channel in a reset condition and does not begin counting until the reset signal is removed. An edge reset resets the channel on the positive going edge of the pulse and begins counting immediately. Wire the positive terminal of the reset device to the positive terminal on the Model 2554-A and the negative wire to the negative terminal.

**NOTE:**

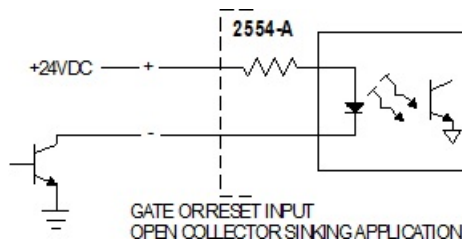
*Reset and gate external inputs may be driven as sourcing or sinking.*

To wire the inputs for sourcing, wire the positive terminal on the Model 2554-A to the switching device output and the negative terminal to the ground of the switching device.



**Figure 16** TTL Sourcing Application

To wire the inputs as sinking, wire the positive terminal on the Model 2554-A to the (+) terminal on the power supply of the external device and negative terminal on the Model 2554-A to the switching device output.

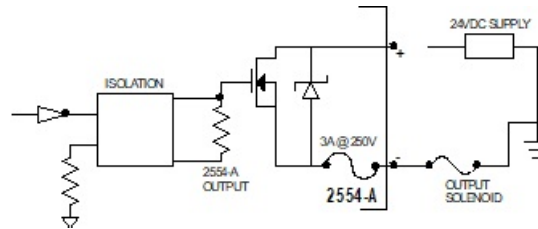


**Figure 17** Open Collector Sinking Application

### 3.4.6 Wiring the Outputs:

Each channel contains a DC output circuit capable of sourcing up to 1.5 amps of current at 28 VDC.

To wire the output, connect the positive terminal of the external DC supply to the positive terminal of the output channel of the Model 2554-A. Connect the load to the negative terminal on the Model 2554-A.



**Figure 18** *Wiring the Outputs*

***WARNING:***

*The output circuits operate independently of the ladder scan. Even if the PLC is in program mode and the conditions are met to initialize the outputs, the outputs will energize.*

***NOTE:***

*The output is protected by a zener diode and a 3 amp, 250V fuse. Replacement fuses are Littlefuse 2173.15 or Bussman GMA-3A.*

### 3.5 Checking Module Operation

First turn on the base power supply. If the module diagnostics detect no problems, the status indicator on the front of the module will light. If the status indicator does not light (or goes out during operation), the module has detected a failure. For information on viewing failed module status, refer to your SIMATIC® TISOFT user manual. To diagnose and correct module failure, refer to Section 6 on Troubleshooting.

You must also check that the module is configured in the PLC. This is important because the module will appear to be functioning regardless of whether it is communicating with the PLC. To view the PLC memory configuration chart listing all slots on the base and the inputs and outputs associated with each slot, refer to your SIMATIC® TISOFT Programming Manual. An example chart is shown in Figure 17.

In this example, the Model 2554-A module is inserted in slot 1 in the I/O base 0. Data for channel 1 appears in word location WX1, data for channel 2 appears in word location WX2, etc. For your particular module, look in the chart for the number corresponding to the slot occupied by the module. If word memory locations appear on this line, then the module is registered in the PLC memory and the module is ready for operation. The Model 2554-A is memory mapped as 4 WX inputs and 4 WY outputs.

I/O MODULE DEFINITION FOR CHANNEL . . . . . 1							BASE . . . . . 00
I/O SLOT	ADDRESS	X	Y	WX	WY	SPECIAL FUNCTION	
01	0001	00	00	<b>4</b>	<b>4</b>	NO	
02	0000	00	00	00	00	NO	
.	.	.	.	.	.	.	
.	.	.	.	.	.	.	
.	.	.	.	.	.	.	
15	0000	00	00	00	00	NO	
16	0000	00	00	00	00	NO	

**Figure 19** Model 2554-A I/O Configuration Chart

If this line is blank or erroneous, re-check the module to ensure that it is firmly seated in the slots. Generate the PLC I/O configuration chart again. If the line is still incorrect, contact your local distributor or CTI at 1-800-537-8398 for further assistance.



---

## **CHAPTER 4. CONFIGURING THE MODULE**

---

Changing the module input channel configuration involves the following steps:

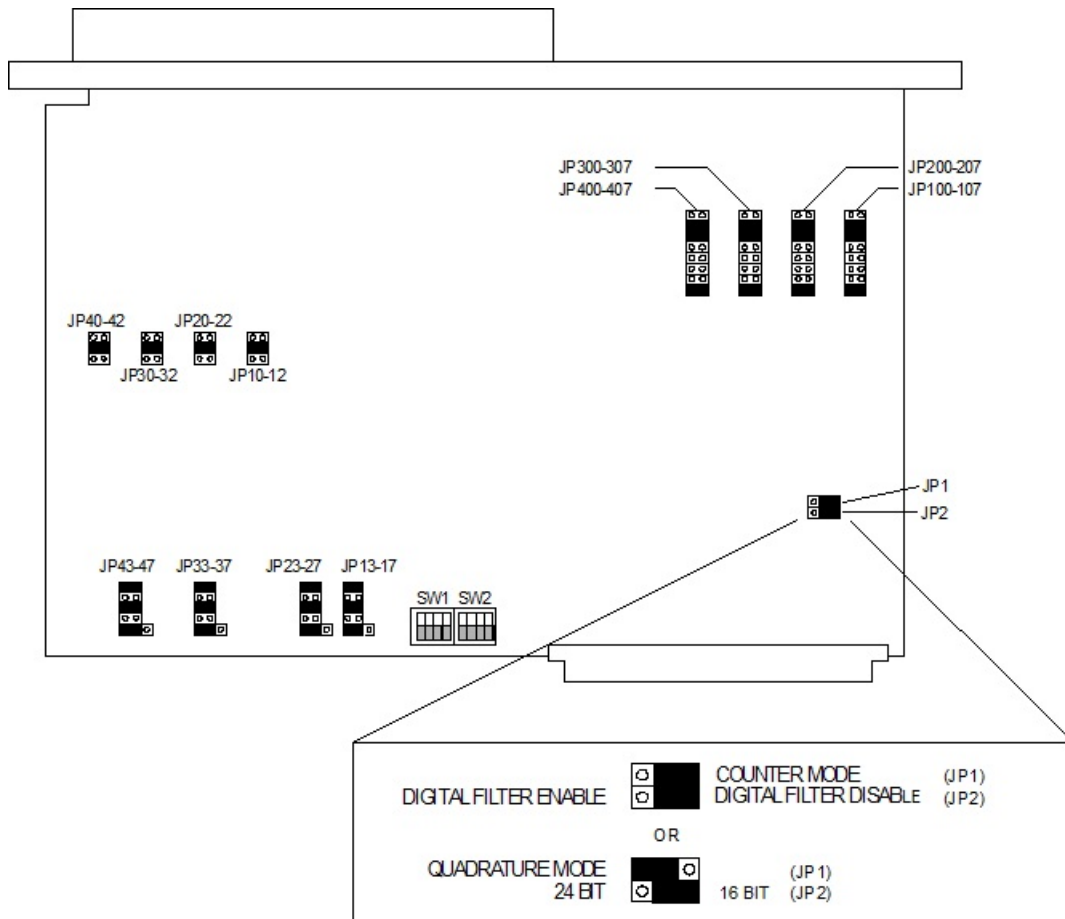
1. Selecting counter mode or quadrature mode for the module.
2. Selecting the proper input signal conditioning.
3. Selecting the proper counting mode for a counter configuration.
4. Selecting the proper gate, reset, and output settings.
5. Logging the configuration jumper settings for future reference.

#### 4.1 Selecting Counter Mode or Quadrature Mode

Jumper JP1 is used to select the operating mode of the module. When jumper JP1 is in the "Counter Mode" position, each of the 4 channels can be independently configured in one of the 4 count modes. When jumper JP1 is in the "Quadrature Mode" position, the module is a quadrature input module.

Jumper JP2 has different functions dependent on JP1 setting. In the "Counter Mode", JP2 is used to enable or disable digital filtering. Digital filtering is used to remove high frequency noise that may be present on the counter input wiring. The digital filtering time constant for the Model 2554-A is 0.3 seconds. This time constant corresponds to a low pass filter with a cut-off frequency equal to 0.53 Hz. With digital filtering selected the Model 2554-A will remove extraneous noise present, starting at 0.53 Hz. When the module is in the "Quadrature Mode", JP2 is used to select 16 bit quadrature or 24 bit quadrature operation. (24 bit quadrature is not supported at this time.)

**Default shipping configuration is Counter Mode with Digital Filter Disable.**



**Figure 20** Model 2554-A Counter Mode or Quadrature Mode Jumpers

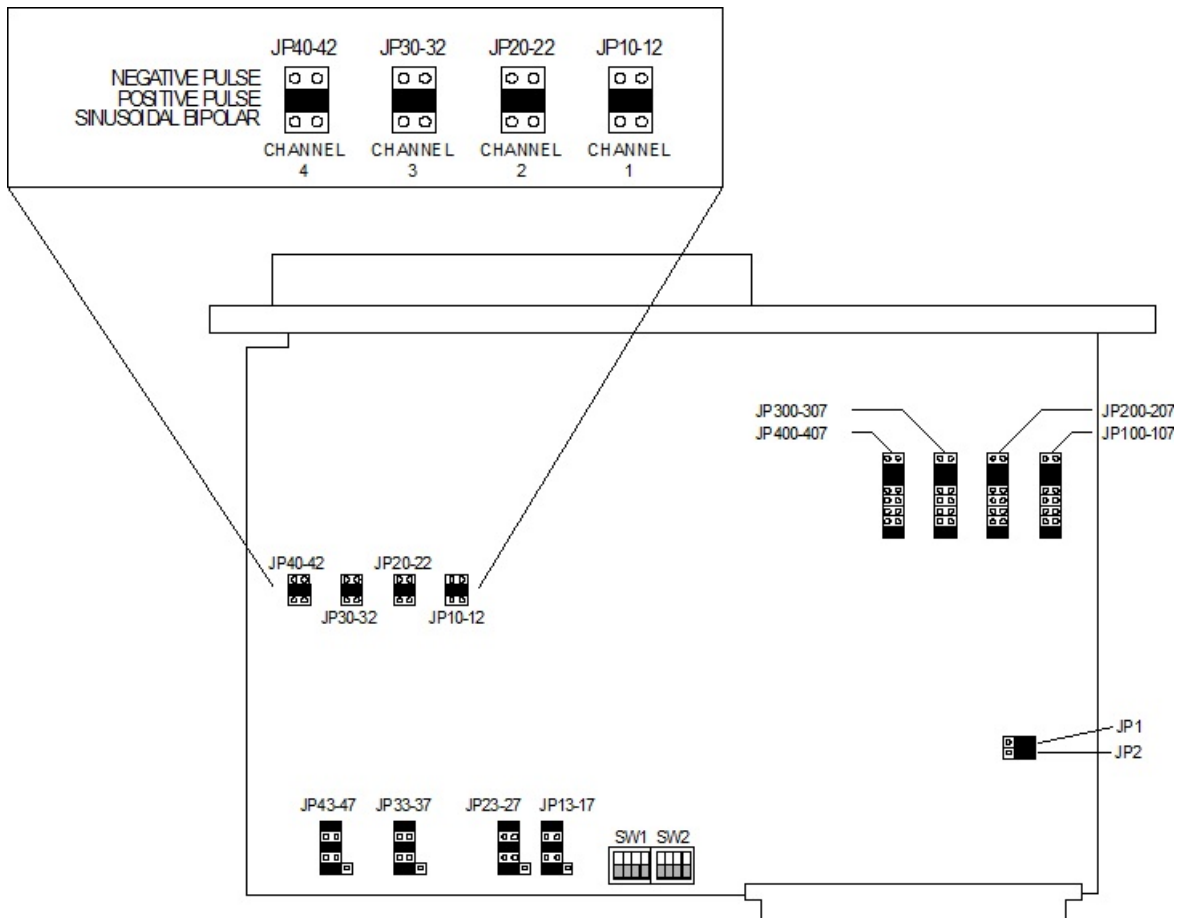
## 4.2 Input Signal Conditioning

Negative Pulse: Devices that generate a negative pulse (between ground and a negative voltage) require the input conditioning jumper to be placed in the top position. (JP40, JP30, JP20, and JP10.)

Positive Pulse: Devices that generate positive pulse (between ground and a positive voltage) should be configured with the jumper in the middle position. (JP41, JP31, JP21, and JP11.)

Bipolar: Devices that generate a sinusoidal output or bipolar output such as a magnetic flow meter require that the signal conditioning jumper be placed in the bottom position. (JP42, JP32, JP22, and JP12.)

**Default shipping configuration is positive pulse on all channels.**

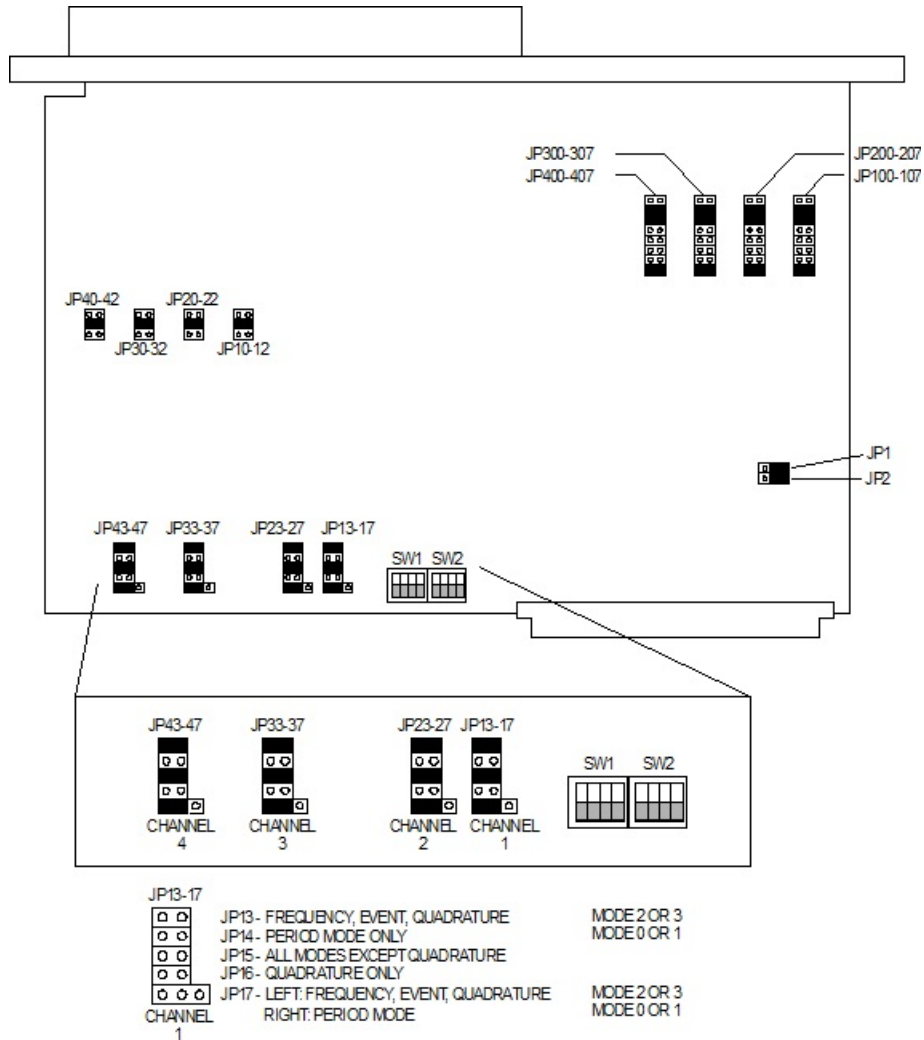


**Figure 21** Model 2554-A Input Signal Conditioning Jumpers

### 4.3 Mode Select Switches and Jumpers

The mode select jumpers are used to set up the module for a specific counting function. It should be noted that each channel can be independently configured for a counting function (when not in quadrature mode). The following diagram can be used to determine the mode jumpers used for a particular channel.

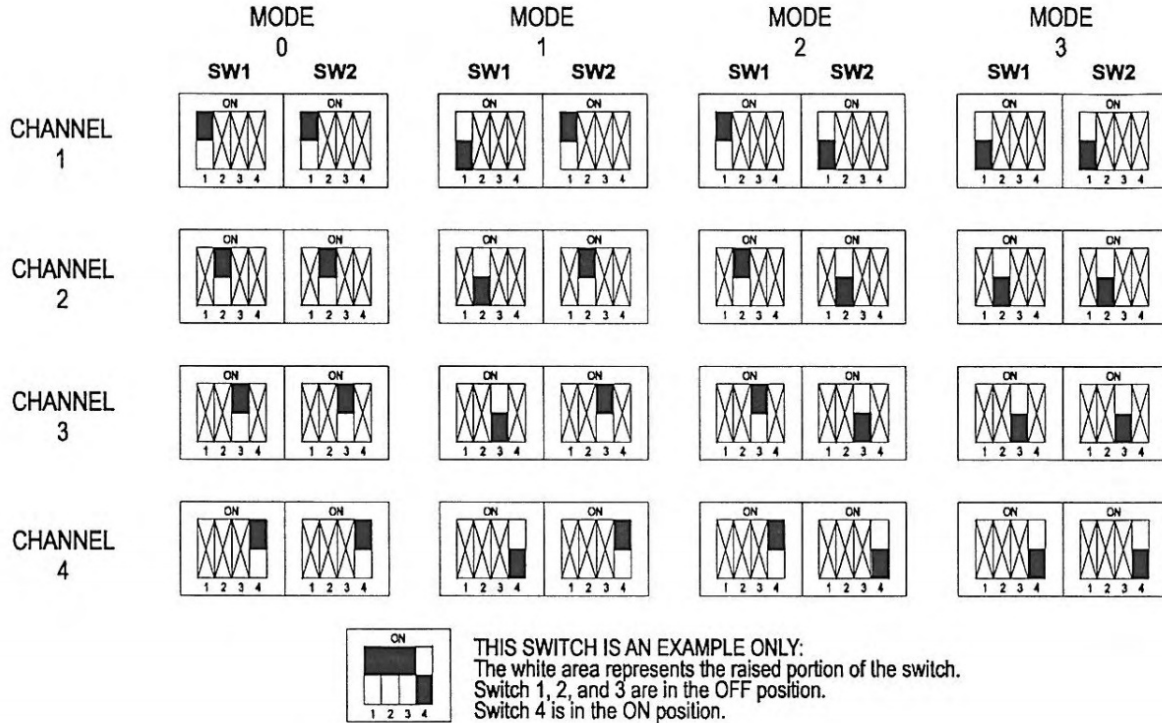
**Default shipping configuration is counter mode (Mode 3) on all channels.**



**Figure 22 Model 2554-A Mode Jumpers**

In addition to the jumper settings, SW1 and SW2 are also required to configure the desired counting mode. The DIP switches are read by the microcomputer and report the hardware configuration selected for each input channel. Each input channel requires two switches to be set: one switch on SW1 and one switch on SW2.

The following matrix can be used to determine the proper settings for SW1 and SW2 for the desired counting mode.



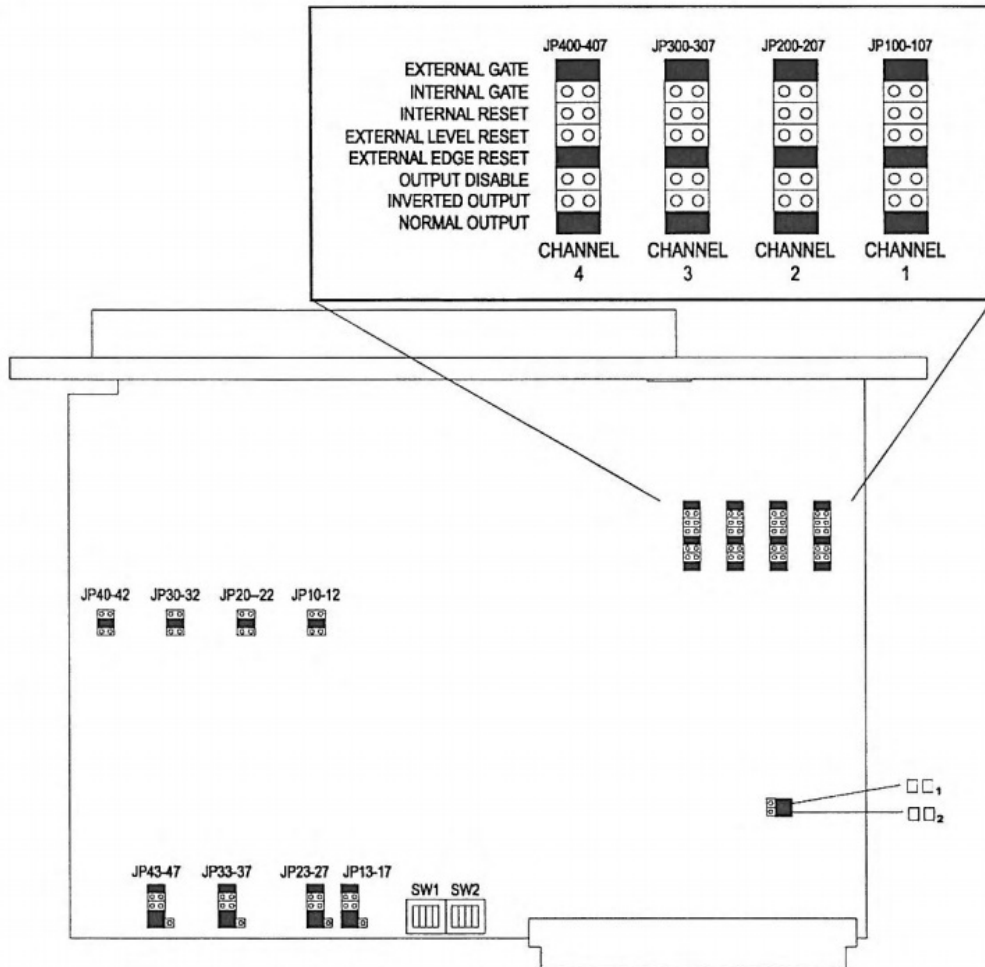
*Figure 23 SW1 and SW2 Settings*

**NOTE:**  
 When the module is configured for quadrature mode, channels 1 and 3 must be set for Mode 3.  
 Channels 2 and 4 are "don't cares".

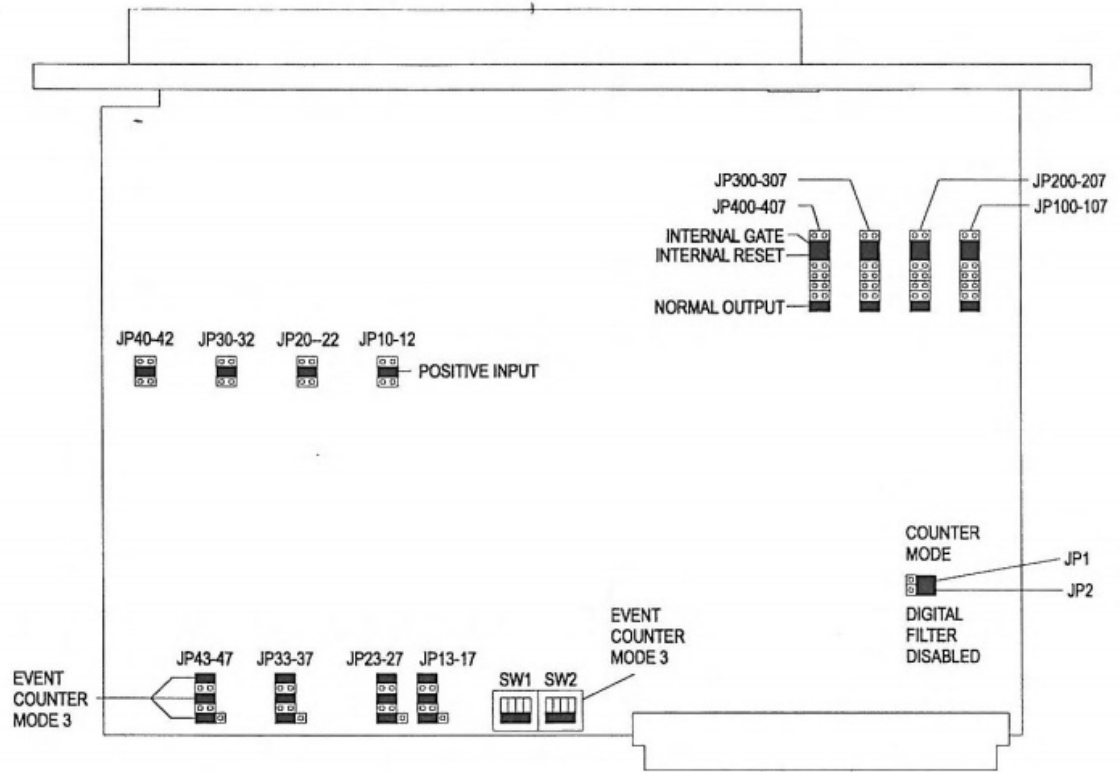
#### 4.4 Gate, Reset, and Output Jumpers

The following diagram shows the jumper locations for the gate, reset, and output control for each channel. Note that the "internal reset" is really just a storage position for the jumper. Internal reset capability is always available.

**The default shipping configuration is internal gate, internal reset, and normal outputs on all channel.**



**Figure 24 Model 2554-A Gate, Reset, and Output Jumpers**



	MSB																LSB															
	1	2	3	4	5	6	7	8	9	10	11	12	13	14	15	16	1	2	3	4	5	6	7	8	9	10	11	12	13	14	15	16
WX1																																
WX2																																
WX3																																
WX4																																
WX5	0	0	0	0	0	0	0	0	0	0	0	0	0	0	0	0	0	0	0	0	0	0	0	0	0	0	0	0	0	0		
WX6	0	0	0	0	0	0	0	0	0	0	0	0	0	0	0	0	0	0	0	0	0	0	0	0	0	0	0	0	0	0		
WX7	0	0	0	0	0	0	0	0	0	0	0	0	0	0	0	0	0	0	0	0	0	0	0	0	0	0	0	0	0	0		
WX8	0	0	0	0	0	0	0	0	0	0	0	0	0	0	0	0	0	0	0	0	0	0	0	0	0	0	0	0	0	0		

Figure 25 Model 2554-A Default Shipping Configuration

## CHAPTER 5. PLC PROGRAMMING EXAMPLE

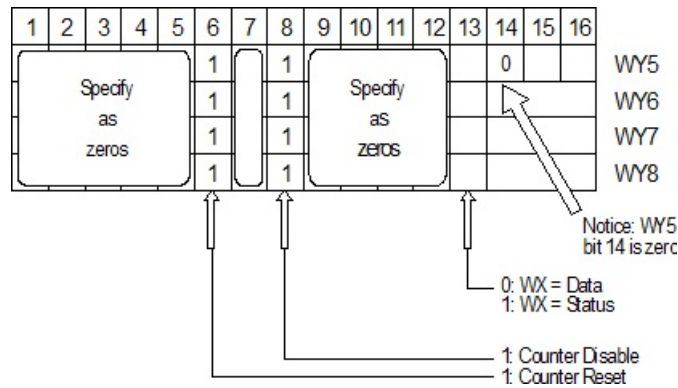
### 5.1 A Programming Example

The following ladder program example is provided to demonstrate how the channel is reset and inhibited for counting, is loaded with a preset value, configured for a status word, output enabled on at preset 1 and off at preset 2, and configured for auto-reset.

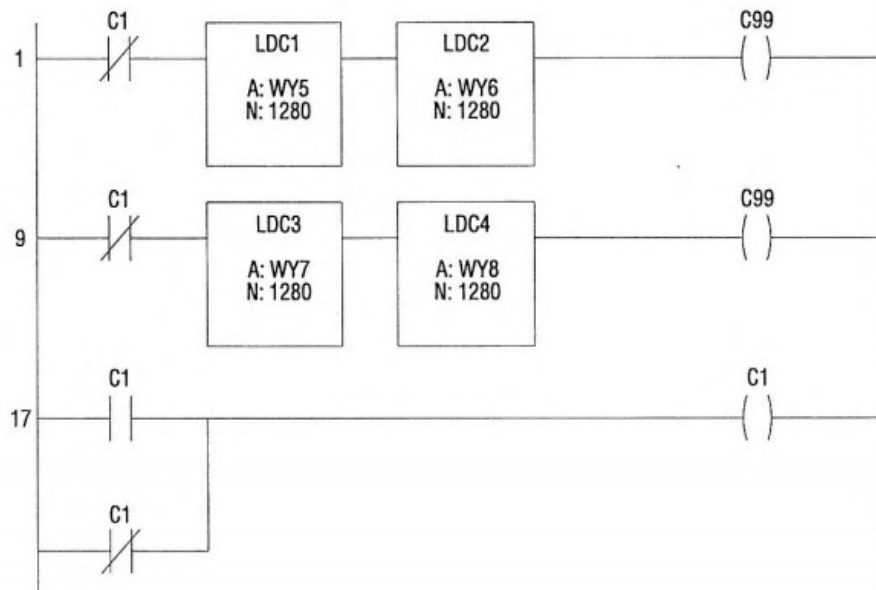
The first rungs which execute write 1280 (0500H) =

**counter reset (WY:6) and  
counter disable (WY:8)**

to all four channels. These rungs are only executed the first scan of ladder logic due to the C1 latch in

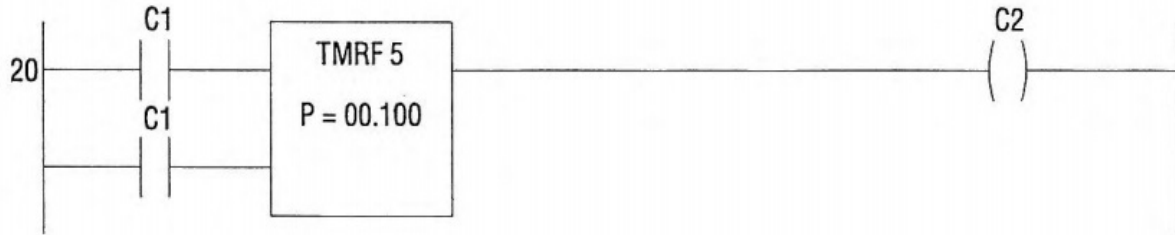


**Figure 27** Reset and Disable Input Counter Channels





The next rung is a timer of 100ms which must time out before any further rungs are executed. Its



purpose is to give the control system time to settle out after a power cycle.

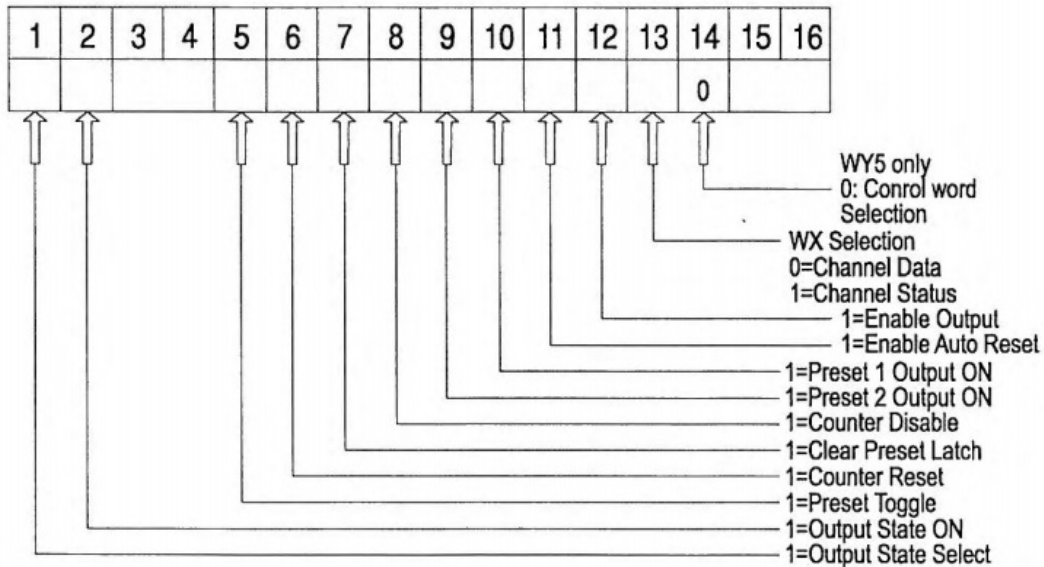
The following rungs load the preset values into all the channels. The rungs execute in "reverse" due to the CR interlocking, i.e. rungs 87 and 99 execute on the first scan after the timer times out, then 73 and 85 on the scan after that, etc. Finally rungs 25, 34, and 43 execute which write the channel setup words 112 (0070H) =

**enable counter (WY:8=0) and  
 preset 1: Output on (WY:10=1) and  
 preset 2: Output off (WY:9=0) and  
 enable auto reset (WY:11=1) and  
 enable ch output (WY:12=1)**

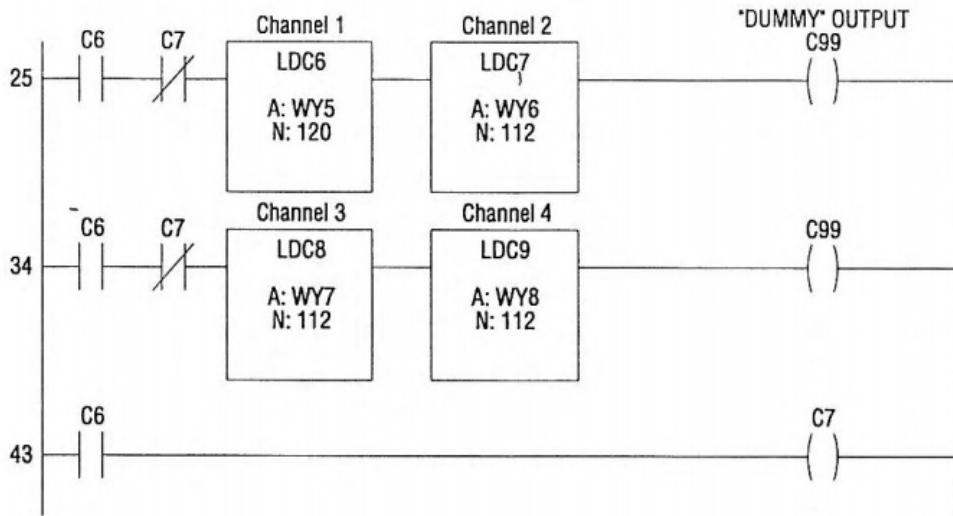
to channels 2 through 4. Channel 1 receives 120 (0078H) = (same as above) plus

**WX=channel status (WY:13=1).**

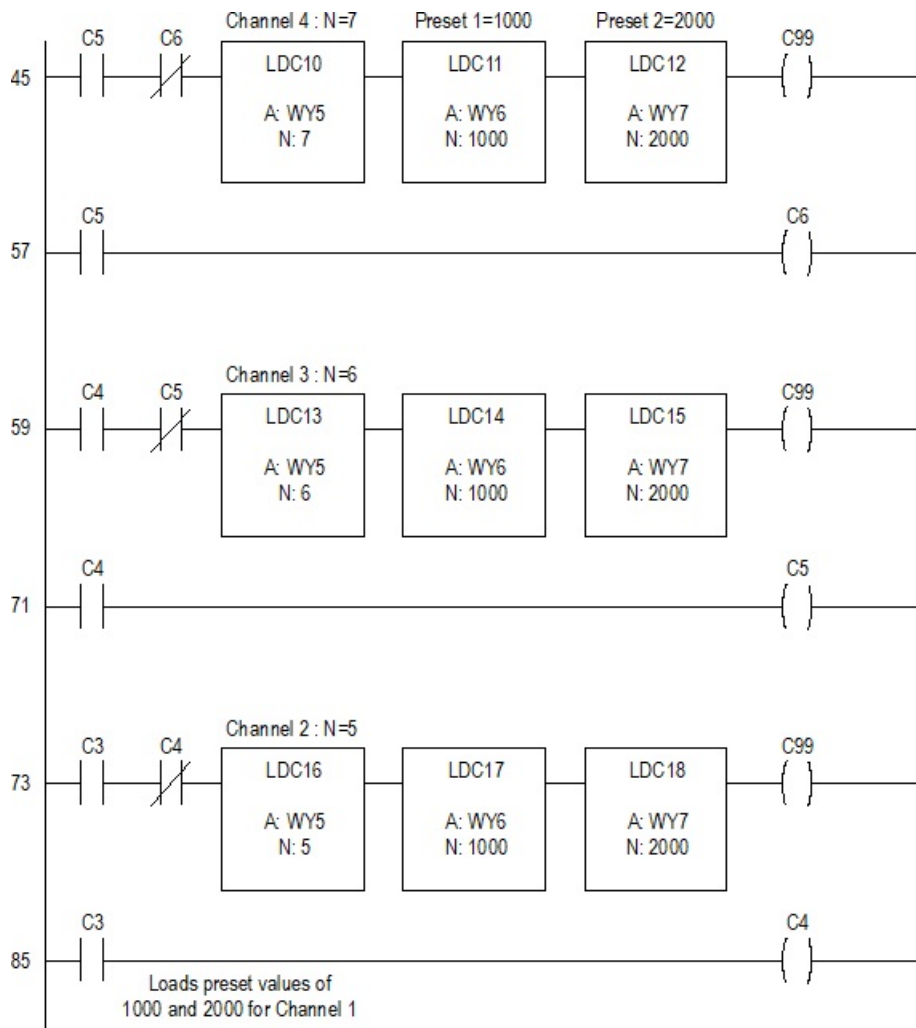
So WX1 will report status and WX2/3/4 will report data.



**Figure 27 Control Word for Sample Application**



### Loading Preset Target Values:

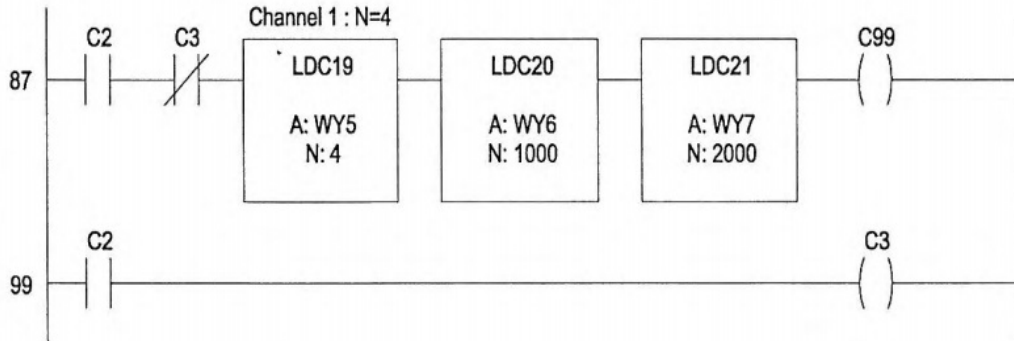


1	2	3	4	5	6	7	8	9	10	11	12	13	14	15	16	
													1	0	0	WY5
						1	1	1	1	1	0	1	0	0	0	WY6 = 1000
				1	1	1	1	1	1	0	1	0	0	0	0	WY7 = 2000
																WY8

Notice: WY5 bit 14 is one

**Figure 31** Loading Preset Values for Channel 1

Now that the presets have been loaded and the counters are enabled, the ladder logic looks for



Channel 1 count to reach preset 1. It does so by doing a BITP on

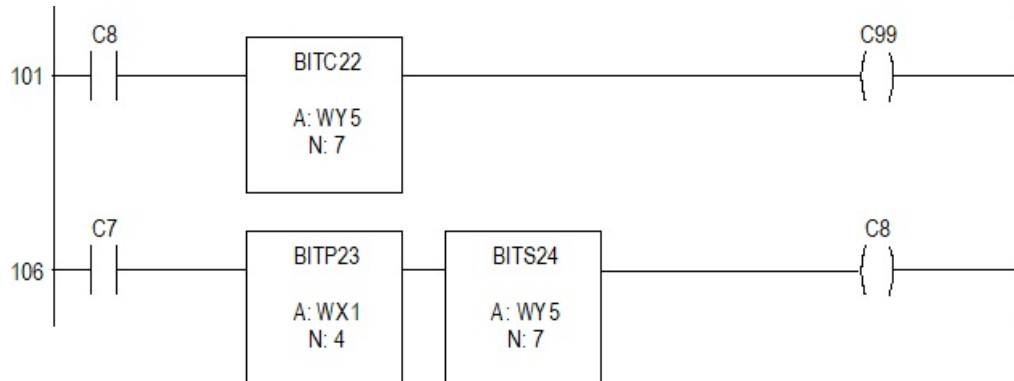
**preset status latch (WX:4)**

in WX1 (which is returning status). This bit, when equal to a 1, indicates the counter has reached the preset value, an auto reset has been performed, and the channel is counting again.

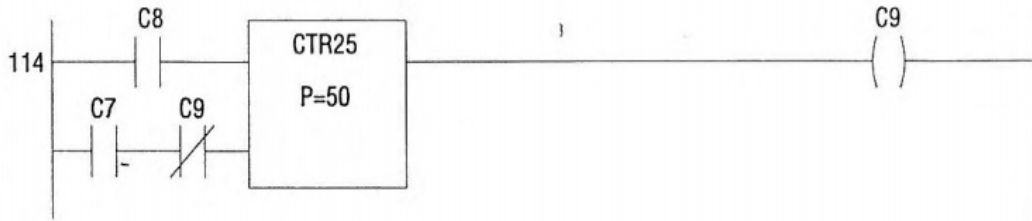
An immediate BITS is done on

**clear preset status latch (WY:7)**

so the latch can be set again the next time the counter reaches preset. On the next scan the BITC in rung 101 resets the clear preset status latch (WY:7) bit.

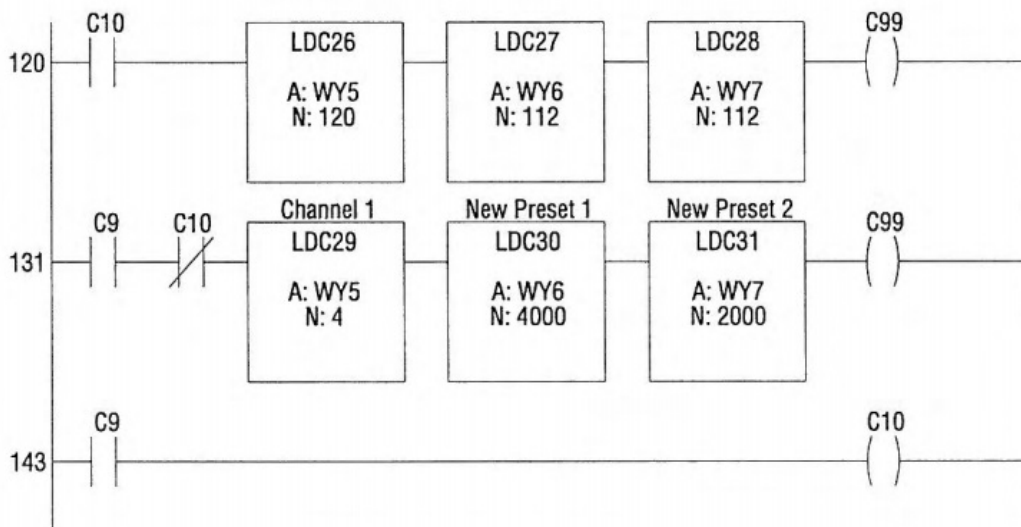


The ladder logic counter keeps track of how many times the preset latch has been set.



The final section of code demonstrates changing a preset value dynamically (while the counter is counting).

When a preset has been reached 50 times, the preset 1 of channel 1 value will be changed to 4000. This happens in rung 131. The logic in rung 120 returns the WY control words to the same value as in rungs 25 and 34. (Note that since WY8 was not changed, there is no need to re-write it.)



**NOTE:**

*If the new preset value were less than the current preset, it would be necessary to check which preset was currently being used so as to not load a value which the count already exceeded. (Refer to Section 2.1).*





---

## CHAPTER 6. TROUBLESHOOTING

---

If the module provides improper readings or the status indicator is not on, use the following chart to determine the appropriate corrective action.

When it is inconvenient to visually check the status indicator, use the SIMATIC® TISOFT "Display Failed I/O" or "Show PLC Diagnostics" support functions. Note that if the module power supply (base supply) fails, the module will still be logged into the PLC even though it is not operating. In this case, "Display Failed I/O" will not provide the information to accurately diagnose the problem.

If after consulting the chart below, you are still unable to diagnose or solve the problem, contact your local distributor or call CTI at 1-800-537-8398 for further assistance.

<b>SYMPTOM</b>	<b>PROBABLE CAUSE</b>	<b>CORRECTIVE ACTION</b>
Active indicator not lit	Base or PLC power off Defective module Blown module fuse (F5)	Turn on base / PLC power Return module for service
Channel indicator not lit	Incorrect signal conditioning	Check signal conditioning jumper and match to input signal level
Gate indicator not lit	Incorrect wiring	Ensure positive voltage on (+) input terminal
Output indicator not lit	No preset condition Output disabled Blown fuse	Counter must reach preset level Check jumper configuration Replace
Incorrect readings in period or frequency mode	Incorrect configuration of jumpers or SW1 and SW2	Check configuration for mode selected
Incorrect readings	Signal conditioning or signal levels not set correctly	Configure signal conditioning, check external input wiring
No output	Jumper disabled Blown fuse	Enable with jumper Replace fuse
Incorrect operation	Not logged in PLC	Use configure I/O function to verify module is logged as 4WX and 4WY memory locations





---

## CHAPTER 7. Quadrature Operation

---

### 7.1 Quadrature Mode Operation

The Model 2554-A high speed counter may be configured for quadrature applications. When configured the entire card is in quadrature mode and 2 channels of counting are supported. There are some differences in the level of support for quadrature mode and there are some reassignments of status bits.

A single 16-bit signed preset can be specified, using the same method as documented for Mode 3 operation.

**NOTE:**

*Two presets for a counter channel are not supported. Also the automatic reset function is not supported in quadrature applications.*

The count value supported in this release is a 16-bit signed integer. Both overflow (count >32767 counts) and underflow (count <-32767 counts) are detected. Status bit #1 can be used for underflow detection.

Status bit #5 “count $\geq$ preset” is supported; however, it means “count $\leq$ preset” if the count (and preset) is negative for example preset = -2000, count = -2500

Status bit #6 “counting to/beyond preset 2”, is re-defined as “**count is negative**”. Application code can then determine if the count is negative without examining actual count values.

Status bit #8 if set to 1 indicates count is UP (A leads B).

Status bit #14 when set to 1 indicates that the 2554-A counter is configured for quadrature mode. This is actually the state of JP1. This does not guarantee that the hardware selection jumpers are properly set. (See Chapter 4.)

The status bits are updated at each backplane interrupt. This means that the status word is dependent on the PLC ladder scan time. If the ladder scan is 100 mSec then the status word update time is the same value.

Both internal with the control word (RLL) and external reset are supported in quadrature mode.

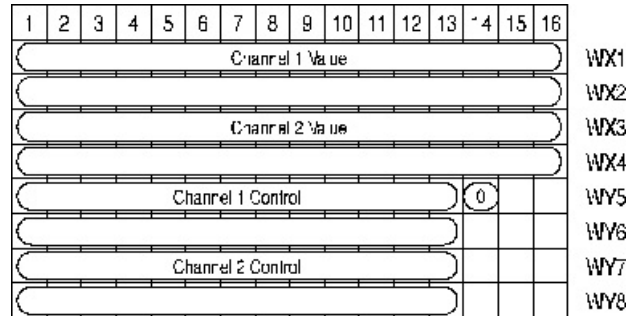
Both internal with the control word and external gating are supported in quadrature mode.

The output can be turned on or off when the channel is reset, as is the case in regular counter mode. The output can be turned on or off when the preset has been reached, but this is polled in the background, so it is not quite as accurate as in regular counter mode.

### 7.2 Quadrature Data Presentation

Quadrature Mode requires an input channel for each A phase and B phase. As a result in Quadrature Mode two counter channels are available for applications.

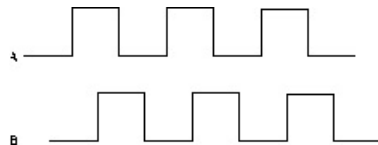
In Quadrature Mode the count value is returned in WX1 and WX3.



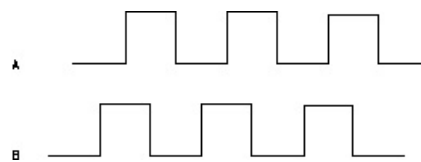
**Figure 35 PLC Interface**

### 7.3 Wiring for Quadrature Mode Operation

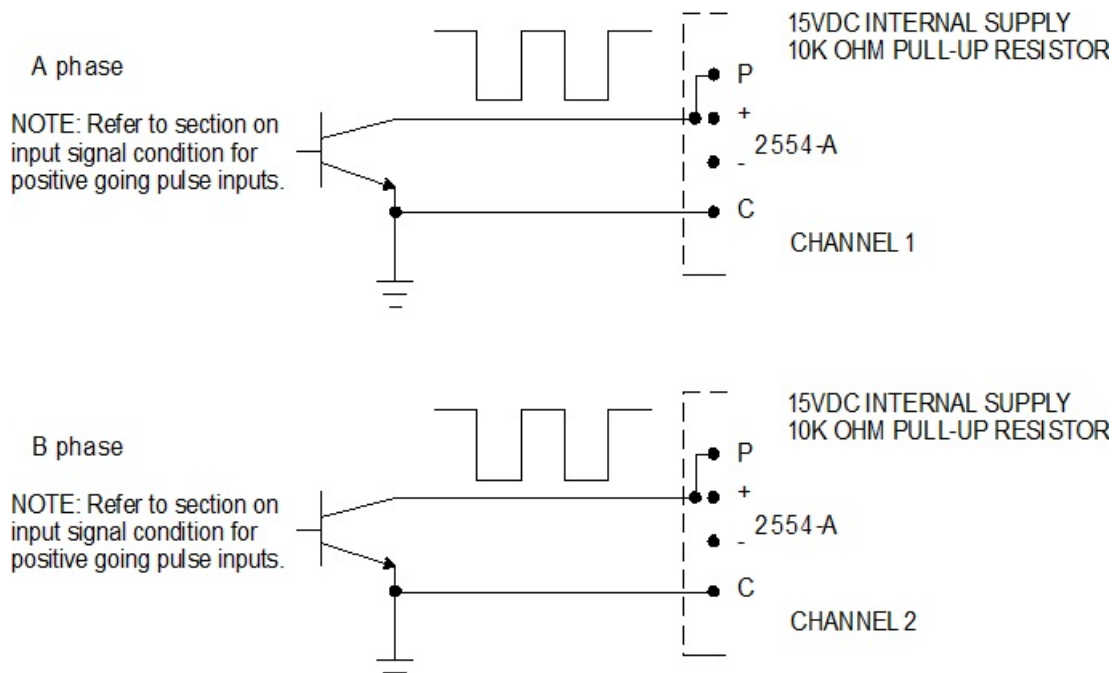
In quadrature encoders there are two output circuits labeled A and B. The phase relationship between these two outputs indicates whether the count value increments or decrements. When A leads B the counter increments to a maximum value of +32,767. When B leads A the counter decrements to a minimum count of -32,767.



**Figure 36 Quadrature Increment**



**Figure 37 Quadrature Decrement**



**Figure 38** *Quadrature Wiring Example*



---

## **SPECIFICATIONS**

---

### **Period Mode Specifications (Modes 0, 1)**

Accuracy:	@ 20 Hz = 0.002% @ 2 KHz = 0.2% @ 10 KHz = 1% @ 20 KHz = 2%
Reports to PLC:	Selectable - Hertz or Microseconds
Update Time:	100 mSec

### **Frequency Counter Mode Specifications (Mode 2)**

Accuracy:	0.01%
Reports to PLC:	Hertz
Update Time:	1 Sec

### **Count Input Specifications**

Input Channels:	4
Input Voltage Range:	Sine wave: 200 mV peak to 56 V peak (140 mVRMS to 40 VRMS) TTL: (less than 0.8 = "0", greater than 2.4 = "1", max input = 28 VDC)
Input Impedance:	10 K ohms
Input Frequency Range:	17 Hz to 65 KHz
Frequency Roll-Off (3dB):	10 KHz
Digital Filtering:	Available for Modes 0 and 1 only 0.3 Sec Time Constant
Signal Input Isolation:	1500 VDC Channel-to-backplane 1500 VDC Channel-to-channel

### **Control Output Specifications**

Outputs Per Module:	4
Isolation:	500 VDC Channel-to-channel 1500 VDC Channel-to-backplane
Output Voltage:	11 to 140 VDC
Output Source Current Per Circuit:	1.5 Amps max

Maximum Surge Current:	3 Amps for 15 Sec
"ON" State Voltage Drop:	0.3 V @ 2.0 Amps
"OFF" State Leakage Current:	125 $\mu$ A @ 125 VDC
Turn On Time:	1 $\mu$ Sec (nominal)
Turn Off Time:	1 $\mu$ Sec (nominal)

### Control Input Specifications

Inputs Per Channel:	2 (1 gate, 1 reset)
Isolation:	500 VDC Channel-to-channel 1500 VDC Channel-to-backplane
Input Voltage:	TTL to 25 VDC
Input Current:	11 mA @ 25 VDC 0.5 mA @ 2.6 VDC
Minimum "ON" pulse width:	Reset (Level triggered) = One PLC scan Reset (Edge triggered) = 150 $\mu$ s Gate (Level triggered) = 150 $\mu$ s

### Mechanical Specifications

Fuses:	3A, 250V (Littlefuse 2173.15 or Bussman GMA-3A)
Field Wiring Connector:	Removable, accepts 14-26 AWG
Module Size:	Single wide 505
Module Power from Base:	4.0 Watts @ 5 VDC
Operating Temperature:	0° to 60°C (32° to 140°F)
Storage Temperature:	-40° to 85°C (-40° to 185°F)
Relative Humidity:	5 to 95% (non-condensing)
Shipping Weight:	1.5 lbs.
Agency Approvals:	UL, UL for Canada FM (Class I Div 2)

*Specifications subject to change without notice.*

---

## **LIMITED PRODUCT WARRANTY**

---

CTI warrants that this CTI Industrial Product shall be free from defects in material and workmanship for a period of one (1) year after purchase from CTI or from an authorized CTI Industrial Distributor. This CTI Industrial Product will be newly manufactured from new and/or serviceable used parts which are equal to new in the Product.

Should this CTI Industrial Product fail to be free from defects in material and workmanship at any time during this one (1) year warranty period, CTI will repair or replace (at its option) parts or Products found to be defective and shipped prepaid by the customer to a designated CTI service location along with proof of purchase date and associated serial number. Repair parts and replacement Product furnished under this warranty will be on an exchange basis and will be either reconditioned or new. All exchanged parts or Products become the property of CTI. Should any Product or part returned to CTI hereunder be found by CTI to be without defect, CTI will return such Product or part to the customer.

This warranty does not include repair of damage to a part or the Product resulting from: failure to provide a suitable environment as specified in applicable Product specifications, or damage caused by an accident, disaster, acts of God, neglect, abuse, misuse, transportation, alterations, attachments, accessories, supplies, non-CTI parts, non-CTI repairs or activities, or to any damage whose proximate cause was utilities or utility like services, or faulty installation or maintenance done by someone other than CTI.

Control Technology Inc. reserves the right to make changes to the Product in order to improve reliability, function, or design in the pursuit of providing the best possible Product. CTI assumes no responsibility for indirect or consequential damages resulting from the use or application of this equipment.

**THE WARRANTY SET FORTH ABOVE IN THIS ARTICLE IS THE ONLY WARRANTY CTI GRANTS AND IT IS IN LIEU OF ANY OTHER IMPLIED OR EXPRESSED GUARANTY OR WARRANTY ON CTI PRODUCTS, INCLUDING WITHOUT LIMITATION, ANY WARRANTY OF MERCHANTABILITY OR OF FITNESS FOR A PARTICULAR PURPOSE AND IS IN LIEU OF ALL OBLIGATIONS OR LIABILITY OF CTI FOR DAMAGES IN CONNECTION WITH LOSS, DELIVERY, USE OR PERFORMANCE OF CTI PRODUCTS OR INTERRUPTION OF BUSINESS, LOSS OF USE, REVENUE OR PROFIT. IN NO EVENT WILL CTI BE LIABLE FOR SPECIAL, INCIDENTAL, OR CONSEQUENTIAL DAMAGES.**

SOME STATES DO NOT ALLOW THE EXCLUSION OR LIMITATION OF INCIDENTAL OR CONSEQUENTIAL DAMAGES FOR CONSUMER PRODUCTS, SO THE ABOVE LIMITATIONS OR EXCLUSIONS MAY NOT APPLY TO YOU.

THIS WARRANTY GIVES YOU SPECIFIC LEGAL RIGHTS, AND YOU MAY ALSO HAVE OTHER RIGHTS WHICH MAY VARY FROM STATE TO STATE.





---

## ***REPAIR POLICY***

---

In the event that the Product should fail during or after the warranty period, a Return Material Authorization (RMA) number can be requested verbally or in writing from CTI main offices. Whether this equipment is in or out of warranty, a Purchase Order number provided to CTI when requesting the RMA number will aid in expediting the repair process. The RMA number that is issued and your Purchase Order number should be referenced on the returning equipment's shipping documentation. Additionally, if under warranty, proof of purchase date and serial number must accompany the returned equipment. The current repair and/or exchange rates can be obtained by contacting CTI's main office at 1-800-537-8398.

When returning any module to CTI, follow proper static control precautions. Keep the module away from polyethylene products, polystyrene products and all other static producing materials. Packing the module in its original conductive bag is the preferred way to control static problems during shipment. Failure to observe static control precautions may void the warranty. For additional information on static control precautions, contact CTI's main office at 1-800-537-8398.

