

**CTI 2557-A SIXTEEN CHANNEL  
ISOLATED RTD INPUT MODULE  
INSTALLATION AND OPERATION GUIDE**

**Ver. 1.3**

**Copyright © 2023 Control Technology Inc.  
All rights reserved.**

This manual is published by Control Technology Inc., 5734 Middlebrook Pike, Knoxville, TN 37921. This manual contains references to brand and product names which are tradenames, trademarks, and/or registered trademarks of Control Technology Inc. 2500 Series®, Siemens® and SIMATIC® are registered trademarks of Siemens AG. Other references to brand and product names are tradenames, trademarks, and/or registered trademarks of their respective holders.

**DOCUMENT DISCLAIMER STATEMENT**

Every effort has been made to ensure the accuracy of this document; however, errors do occasionally occur. CTI provides this document on an "as is" basis and assumes no responsibility for direct or consequential damages resulting from the use of this document. This document is provided without express or implied warranty of any kind, including but not limited to the warranties of merchantability or fitness for a particular purpose. This document and the products it references are subject to change without notice. If you have a comment or discover an error, please call us toll-free at 1-800-537-8398.

Revision History		
Rev	Date	Description
1.0		Initial Release
1.1		Added Pics
1.2	06/14/2023	Added new Default Configuration for Disabled Digital Filtering. Corrected model number in contents. Multiple correction throughout IOG. Primarily typing errors and wrong symbols.
1.3	07/12/2023	Changed the Default Configuration back to Digital Filtering Enabled

---

## PREFACE

---

This *Installation and Operation Guide* provides installation and operation instructions for the CTI 2557-A Sixteen Channel Isolated RTD Input Module for CTI's 2500 Series 2500® Processors as well as the legacy SIMATIC® 505 programmable controllers. We assume you are familiar with the operation of CTI's 2500 Series 2500® Processors and SIMATIC® Series 505 programmable controllers. Refer to the appropriate CTI's Series 2500® documentation for Processors and I/O module operation.

This *Installation and Operation Guide* is organized as follows:

Chapter 1 provides a description of the module.

Chapter 2 covers installation and wiring.

Chapter 3 is a guide to troubleshooting.

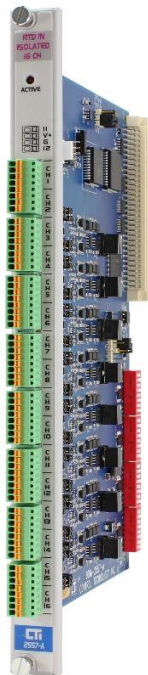

*Figure 1 The 2557-A 16 Channel RTD Input Module*

---

## TABLE OF CONTENTS

---

PREFACE .....	3
TABLE OF CONTENTS .....	4
TABLE OF FIGURES .....	6
USAGE CONVENTIONS .....	9
CHAPTER 1. DESCRIPTION .....	1
1.1 Asynchronous Operation .....	2
1.1.1 Compatibility with Immediate I/O .....	2
1.2 100 Ohm, 10 Ohm, 120 Ohm RTDs, or Millivolt Inputs.....	2
1.3 Digital Word Map.....	2
1.4 RTD Input to Digital Conversion .....	2
1.4.1 Engineering Units .....	3
1.4.2 Scale Units.....	3
1.5 Effect of Out-of-Range Input Signals .....	4
1.6 Resolution.....	5
CHAPTER 2. INSTALLATION .....	6
2.1 Planning the Installation .....	6
2.2 Calculating the I/O Base Power Budget .....	6
2.3 Unpacking the Module .....	6
2.4 Configuring the Module .....	7
2.4.1 Selecting Temperature or Millivolt Input .....	7
2.4.2 Selecting 2 and 3 Wire or 4 Wire Operation.....	8
2.4.3 Selecting 10 Ohm RTD Inputs.....	8
2.4.4 Selecting PLC Login Mode .....	8
2.4.5 Selecting Digital Filtering.....	8
2.4.6 Select Degrees Celsius or Fahrenheit .....	8
2.4.7 Selecting Data Scaling.....	9
2.5 Inserting the Module Into the I/O Base.....	11
2.6 Wiring the Input Connectors .....	12
2.6.1 Connecting the Shield Wiring .....	15
2.7 Checking Module Operation.....	16
CHAPTER 3. TROUBLESHOOTING .....	18
SPECIFICATIONS .....	19
Specifications subject to change without notice. ....	19
JUMPER SETTINGS LOG SHEET.....	20
USER NOTES.....	21

LIMITED PRODUCT WARRANTY .....22

    THE WARRANTY SET FORTH ABOVE IN THIS ARTICLE IS THE ONLY WARRANTY  
    CTI GRANTS AND IT IS IN LIEU OF ANY OTHER IMPLIED OR EXPRESSED  
    GUARANTY OR WARRANTY ON CTI PRODUCTS, INCLUDING WITHOUT  
    LIMITATION, ANY WARRANTY OF MERCHANTABILITY OR OF FITNESS FOR A  
    PARTICULAR PURPOSE AND IS IN LIEU OF ALL OBLIGATIONS OR LIABILITY  
    OF CTI FOR DAMAGES IN CONNECTION WITH LOSS, DELIVERY, USE OR  
    PERFORMANCE OF CTI PRODUCTS OR INTERRUPTION OF BUSINESS, LOSS OF  
    USE, REVENUE OR PROFIT. IN NO EVENT WILL CTI BE LIABLE FOR SPECIAL,  
    INCIDENTAL, OR CONSEQUENTIAL DAMAGES. ....22

REPAIR POLICY .....23

---

## **TABLE OF FIGURES**

---

Figure 1 The 2557-A 16 Channel RTD Input Module .....	iii
Figure 2 2557-A Module Front View.....	1
Figure 3 Word Input to the PLC from the Module.....	2
Figure 4 Example Change Input Level.....	3
Figure 5 Effect of Voltage Input - 100 Ohm Platinum.....	4
Figure 6 Effect of Voltage Input - 120 Ohm Nickel .....	4
Figure 7 Effect of Voltage Input - 10 Ohm Copper .....	5
Figure 8 Effect of Voltage Input - Millivolts .....	5
Figure 9 Input Resolution.....	5
Figure 10 Factory Configuration Jumper Settings .....	9
Figure 11 Configuration Jumper Locations .....	10
Figure 12 2557-A Module PCB Layout .....	11
Figure 13 Copper Wire Table at 25 Degrees Celsius .....	12
Figure 14 Removable Wiring Connector Wiring Diagram .....	13
Figure 15 Wiring Diagram for 2, 3 , 4 Wire RTDs and Millivolt Signals .....	14
Figure 16 Cable Grounding .....	16
Figure 17 Example I/O Configuration Chart .....	17
Figure 18 Troubleshooting Matrix .....	18

---

## **USAGE CONVENTIONS**

---

***NOTE:***

*Notes alert the user to special features or procedures.*

***CAUTION:***

*Cautions alert the user to procedures which could damage equipment.*

***WARNING:***

*Warnings alert the user to procedures which could damage equipment and endanger the user.*





---

## CHAPTER 1. DESCRIPTION

---

This *Installation and Operation Guide* provides installation and operation instructions for the CTI 2557-A 16-Channel Isolated RTD Input Module for CTI 2500 Series® and SIMATIC® 505 programmable controllers. We assume you are familiar with the operation of the CTI 2500 Series® programmable controllers. Refer to the appropriate user documentation for specific information on the CTI programmable controllers and I/O modules.

The Model 2557-A is designed to translate 10 Ohm copper, 100 Ohm platinum and, 120 Ohm nickel RTDs or millivolt input signals into scaled digital words which are then sent to the programmable controller (PLC). The 2557-A RTD Input Module features built-in independent two, three, or four lead compensation for each RTD input. The 2557-A uses 8 8 point removable wiring connectors. The connectors are provided with the module. Support for other RTD types is available through special request from the factory. Call CTI at 1-800-537-8398 to determine if support is available for your special RTD type.

2500 Series®

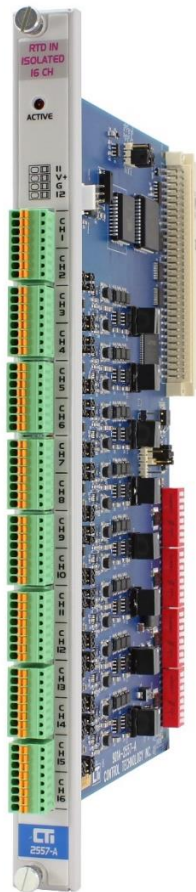

Figure 2 2557-A Module Front View

## 1.1 Asynchronous Operation

The module operates asynchronously with respect to the PLC; a scan of the PLC and input sampling of the module do not occur at the same time. Instead, the module will translate all inputs in one module update (20 milliseconds maximum) and store the translated words in a buffer memory. The PLC retrieves the stored words from the module buffer memory at the start of the I/O scan.

### 1.1.1 Compatibility with Immediate I/O

The Model 2557-A has been tested and is compatible with the Immediate read function of the SIMATIC® 545 and 555 PLC.

## 1.2 100 Ohm, 10 Ohm, 120 Ohm RTDs, or Millivolt Inputs

Each of the module's 16 channels may be configured to receive either a 100 Ohm platinum RTD or a 120 Ohm nickel RTD or a 10 Ohm copper RTD input signal (two, three or four wire) or a DC voltage signal ranging from 0 to 100 millivolts. Selection of 10 Ohm, 100 Ohm or 120 Ohm RTDs or millivolts are made via internal switch and jumper settings.

## 1.3 Digital Word Map

RTD and/or millivolt signals are translated into a 14-bit digital word. Since the PLC requires a 16-bit input word, the 14-bit value from the converter is placed into a 16-bit word for transmittal to the PLC. As shown in the following figure, of the two bits not used for the digital word, one is used to show the sign of the word, while the other is used to note values which are "overrange or underrange."

### 1.4 RTD Input to Digital Conversion

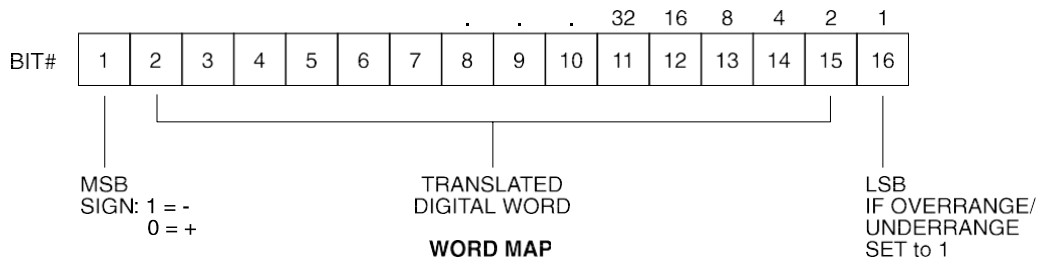

Figure 3 Word Input to the PLC from the Module

### 1.4.1 Engineering Units

The following equations may be used to calculate the digital word in decimal format which will result from a particular RTD input:

$$\begin{aligned} \text{RTD Mode, Digital Word (WX)} &= \text{Degrees} \times 10 \\ \text{Millivolt Mode, Digital Word (WX)} &= \text{Millivolts} \times 100 \end{aligned}$$

As an example, the following figure illustrates the effects of a change in input level going from 0 to 102.4 degrees in the RTD Input Mode.

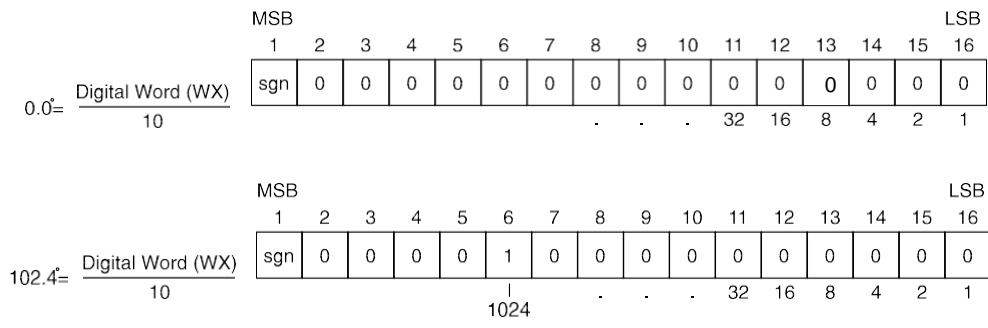

Figure 4 Example Change Input Level

### 1.4.2 Scale Units

When data format is selected as SCALE the full temperature range of the RTD is scaled as an unsigned integer from 0-32000. The following formula may be used to calculate the scaled integer value:

$$\text{Scaled Integer} = (\text{measured temp} - \text{min temp}) \div (\text{max temp} - \text{min temp}) \times 32000$$

For example the scaled integer offset at 0°C for a 100Ω Pt RTD is:

$$\text{Scaled Integer} = 0 - (-199.8) \div (849 - (-199.8)) \times 32000 = 6091$$

### 1.5 Effect of Out-of-Range Input Signals

RTD inputs exceeding 849.8 degrees C for 100 Ohm platinum or 260.0 degrees C for 120 Ohm nickel and 10 Ohm copper will cause the overrange bit to be set. A maximum temperature of 849.9 degrees C for 100 Ohm platinum or 260.1 degrees C for 120 Ohm nickel and 10 Ohm copper will be returned for any positive overrange input.

Similarly an input below -199.8 degrees C for 100 Ohm platinum or -79.8 degrees C for 120 Ohm nickel or -100 degrees C for 10 Ohm copper will cause the under range bit to be set.

**NOTE:**  
The Model 2557-A uses the least significant bit (16) to indicate an open RTD. The value of this bit is set to 1 when this condition occurs.

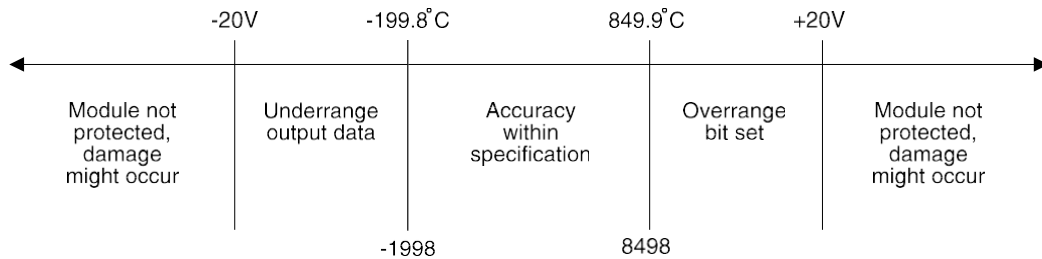

Figure 5 Effect of Voltage Input - 100 Ohm Platinum

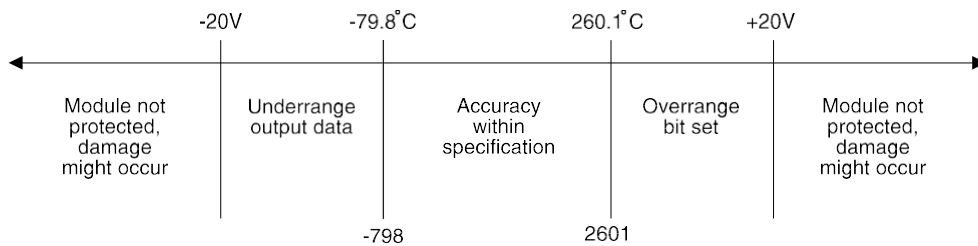
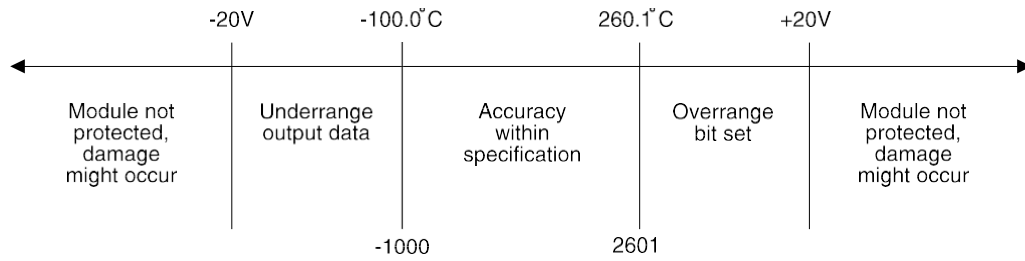
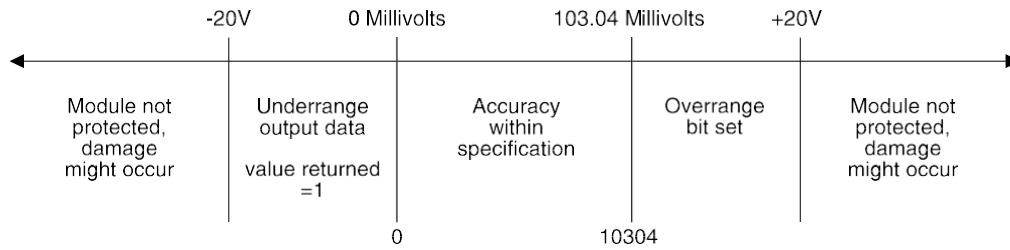

Figure 6 Effect of Voltage Input - 120 Ohm Nickel



*Figure 7 Effect of Voltage Input - 10 Ohm Copper*



*Figure 8 Effect of Voltage Input - Millivolts*

Millivolt inputs exceeding 103.04 millivolts will cause the overrange bit to be set. A reading of 103.05 millivolts will be returned for any positive over-range input.

Similarly, a millivolt input below 0 millivolts will cause the under-range bit to be set. A reading of 1 millivolt will be returned for any negative under-range input.

### ***1.6 Resolution***

The module has a resolution of approximately 0.1 degrees C, 0.2 degrees F or exactly 0.01 millivolts. The chart below shows the corresponding input resolution per step for each of the input configuration modes:

UNITS	DIGITAL COUNTS/STEP	INPUT RESOLUTION PER STEP
Temp Degrees C	2	~ 0.1°C
Temp Degrees F	2	~ 0.2°F
Millivolts	2	0.01 Millivolts

*Figure 9 Input Resolution*

---

## CHAPTER 2. INSTALLATION

---

The installation of the 2557-A Sixteen Channel RTD Input Module involves the following steps:

1. Planning the installation
2. Configuring the module
3. Inserting the module into the I/O base
4. Wiring the module input connector
5. Checking module operation

The steps listed above are explained in detail in the following pages.

### ***2.1 Planning the Installation***

Planning is the first step in the installation of the module. This involves calculating the I/O base power budget and routing the input signal wiring to minimize noise. The following sections discuss these important considerations.

### ***2.2 Calculating the I/O Base Power Budget***

The Model 2557-A requires 5 watts of +5 VDC power from the I/O base. Use this figure to verify that the base power supply capacity is not exceeded.

### ***2.3 Unpacking the Module***

Open the shipping carton and remove the special anti-static bag which contains the module.

**CAUTION:**

**HANDLING STATIC SENSITIVE DEVICES**

*The components on the 2557-A module printed circuit card can be damaged by static electricity discharge. To prevent this damage, the module is shipped in a special anti-static bag. Take the following precautions before removing the module from the bag, when opening the module, and when handling the printed circuit card during configuration.*

*Discharge any static potential by holding the module in its anti-static bag and touch the metal chassis of the PLC. During the configuration step, hold the printed circuit card only by its edges. Do not touch the circuit card pin connectors, or solder connections.*

After discharging any static build-up, remove the module from the static bag. Do not discard the static bag. You will need it for the following configuration procedure.

## 2.4 Configuring the Module

The Model 2557-A must be configured for 10 Ohm copper, 100 Ohm platinum or 120 Ohm nickel RTDs (2, 3 or 4 wire) or millivolt range and digital filtering/no filtering mode before wiring the input connectors and inserting the module into the I/O base.

**NOTE:**  
*As shipped, all input channels are configured 100 Ohm platinum, 3 wire RTDs, degrees Centigrade and digital filtering disabled.*

Configuring the module is a two step process. Hardware jumpers are positioned to provide proper gain and lead wire compensation for either 3 wire or 4 wire RTDs. DIP switches are provided to inform the microprocessor the changes made to the hardware.

Changing the module input channel configuration involves the following steps:

1. Selecting temperature or millivolt measurement via DIP switch
2. Selecting 3 or 4 wire compensation
3. Selecting 100 Ohm platinum, 120 Ohm nickel or 10 Ohm copper input mode for each channel
4. Selecting standard login mode (16WX) or Advanced Operating Mode
5. Selecting digital filtering or no filtering for the module
6. Selecting degrees C or F for the module
7. Selecting Engr units or SCALE units for module
8. Logging the configuration jumper settings for future reference

Each of these steps is described in the following sections.

### 2.4.1 Selecting Temperature or Millivolt Input

No hardware changes are required for millivolt inputs. To select millivolt input mode for an input turn OFF the M and L switch for the input channel. (See Figure 11 and 12.) To select a particular RTD probe for each channel configure the M and L switch.

M	L	
0	0	Millivolt
0	1	10 $\Omega$ Cu
1	0	100 $\Omega$ Pt
1	1	120 $\Omega$ Ni

**NOTE:**  
*Each channel contains a jumper to select between 2, 3 and 4 wire RTD elements. (See Figure 11, JP68). For 2 wire and 3 wire RTDs no change is required. For 4 wire RTDs the jumper should be removed and placed on a single pin for storage.*

### ***2.4.2 Selecting 2 and 3 Wire or 4 Wire Operation***

As shipped the module is ready to accept 2 and 3 wire RTDs. To configure an input channel for 4 wire operation requires the following steps:

1. Remove the 3 wire select jumper JP68-JP83 for the appropriate input channel and store on a single pin.
2. Move 2 input jumpers/channel to the 4 wire position. For example: To configure Channel 1 move JP1 and JP2 to the 4 wire position. (See Figure 11.)

### ***2.4.3 Selecting 10 Ohm RTD Inputs***

If a 10 Ohm RTD is selected the gain of the input amplifier must be increased to process the smaller signal levels. (See Figure 11.) JP49-JP64 are the amplifier gain select jumpers for Channels 1-16. No jumper changes are required to select 100 $\Omega$  or 120 $\Omega$  RTD.

### ***2.4.4 Selecting PLC Login Mode***

Locate JP67 on the printed circuit board to select PLC Login Mode (See Figure 12 2557-A Module PCB Layout). Standard login is 16 WX registers in the PLC. Advanced Operating Mode logs in as 16 X, 16 Y, 32 WX and 32 WY registers. Consult the CTI 255x Sixteen Channel Advanced Function Programming Reference Manual, if the advanced operating mode is to be selected.

### ***2.4.5 Selecting Digital Filtering***

Locate the Digital Filtering Jumper JP65 (see Figures 11 and 12). To enable digital filtering, set the jumper in the ENABLED position. Since many analog input signals contain noise, CTI recommends using digital filtering unless maximum response time is required. The module is shipped with Digital Filtering Disabled. Default configuration is Digital Filtering Enabled.

### ***2.4.6 Select Degrees Celsius or Fahrenheit***

Locate the temperature scaling jumper JP66 on the righthand side of the module (see Figure 11) and select either degrees Fahrenheit or Celsius by positioning the jumper in the DEG F or DEG C position.



### 2.4.7 Selecting Data Scaling

Locate JP90 on the printed circuit board (See Figure 11 and 12). Select DISABLE to present data to the PLC as temperature X10 or millivolts X100. Select ENABLE to scale and present the data as an unsigned integer from 0-32000.

CHANNEL NUMBER	3 WIRE / 4 WIRE RTD COMPENSATION JUMPERS			MODE POSITION		DIP SWITCH RECORD <small>RECORD POSITION OF SWITCH FOR EACH CHANNEL</small>			MEASUREMENT TYPE				
	CHECK JUMPERS FOR CORRECT COMPENSATION			CIRCLE MODE SELECTED		MSB	LSB		MSB <sub>1</sub>	LSB <sub>1</sub>	MSB <sub>0</sub>	LSB <sub>0</sub>	MSB <sub>0</sub>
1	JP1	JP2	JP68	4 WIRE	3 WIRE	ON	1	OFF	120 OHM	100 OHM	10 OHM	Millivolts	
2	JP3	JP4	JP69	4 WIRE	3 WIRE	2			120 OHM	100 OHM	10 OHM	Millivolts	
3	JP5	JP6	JP70	4 WIRE	3 WIRE	3			120 OHM	100 OHM	10 OHM	Millivolts	
4	JP7	JP8	JP71	4 WIRE	3 WIRE	4			120 OHM	100 OHM	10 OHM	Millivolts	
5	JP9	JP10	JP72	4 WIRE	3 WIRE	5			120 OHM	100 OHM	10 OHM	Millivolts	
6	JP11	JP12	JP73	4 WIRE	3 WIRE	6			120 OHM	100 OHM	10 OHM	Millivolts	
7	JP13	JP14	JP74	4 WIRE	3 WIRE	7			120 OHM	100 OHM	10 OHM	Millivolts	
8	JP15	JP16	JP75	4 WIRE	3 WIRE	8			120 OHM	100 OHM	10 OHM	Millivolts	
9	JP17	JP18	JP76	4 WIRE	3 WIRE	9			120 OHM	100 OHM	10 OHM	Millivolts	
10	JP19	JP20	JP77	4 WIRE	3 WIRE	10			120 OHM	100 OHM	10 OHM	Millivolts	
11	JP21	JP22	JP78	4 WIRE	3 WIRE	11			120 OHM	100 OHM	10 OHM	Millivolts	
12	JP23	JP24	JP79	4 WIRE	3 WIRE	12			120 OHM	100 OHM	10 OHM	Millivolts	
13	JP25	JP26	JP80	4 WIRE	3 WIRE	13			120 OHM	100 OHM	10 OHM	Millivolts	
14	JP27	JP28	JP81	4 WIRE	3 WIRE	14			120 OHM	100 OHM	10 OHM	Millivolts	
15	JP29	JP30	JP82	4 WIRE	3 WIRE	15			120 OHM	100 OHM	10 OHM	Millivolts	
16	JP31	JP32	JP83	4 WIRE	3 WIRE	16			120 OHM	100 OHM	10 OHM	Millivolts	

All Channels 1-16	LOGIN MODE JUMPER JP67	DIGITAL FILTERING JUMPER JP65	FAHRENHEIT/CENTRIGRADE SELECTION JP66	ENGR/SCALE UNITS JP90
		LEFT – 16WX RIGHT - Advanced	LEFT – Filtering Disabled RIGHT – Filtering Enabled	LEFT – Degrees C RIGHT – Degrees F

Figure 10 Factory Configuration Jumper Settings

**NOTE:**  
In the sample chart above the standard shipping configuration is indicated as 3 wire 100Ω. Pt, 16 WX, filtering Disabled, degrees C and scaling disabled.



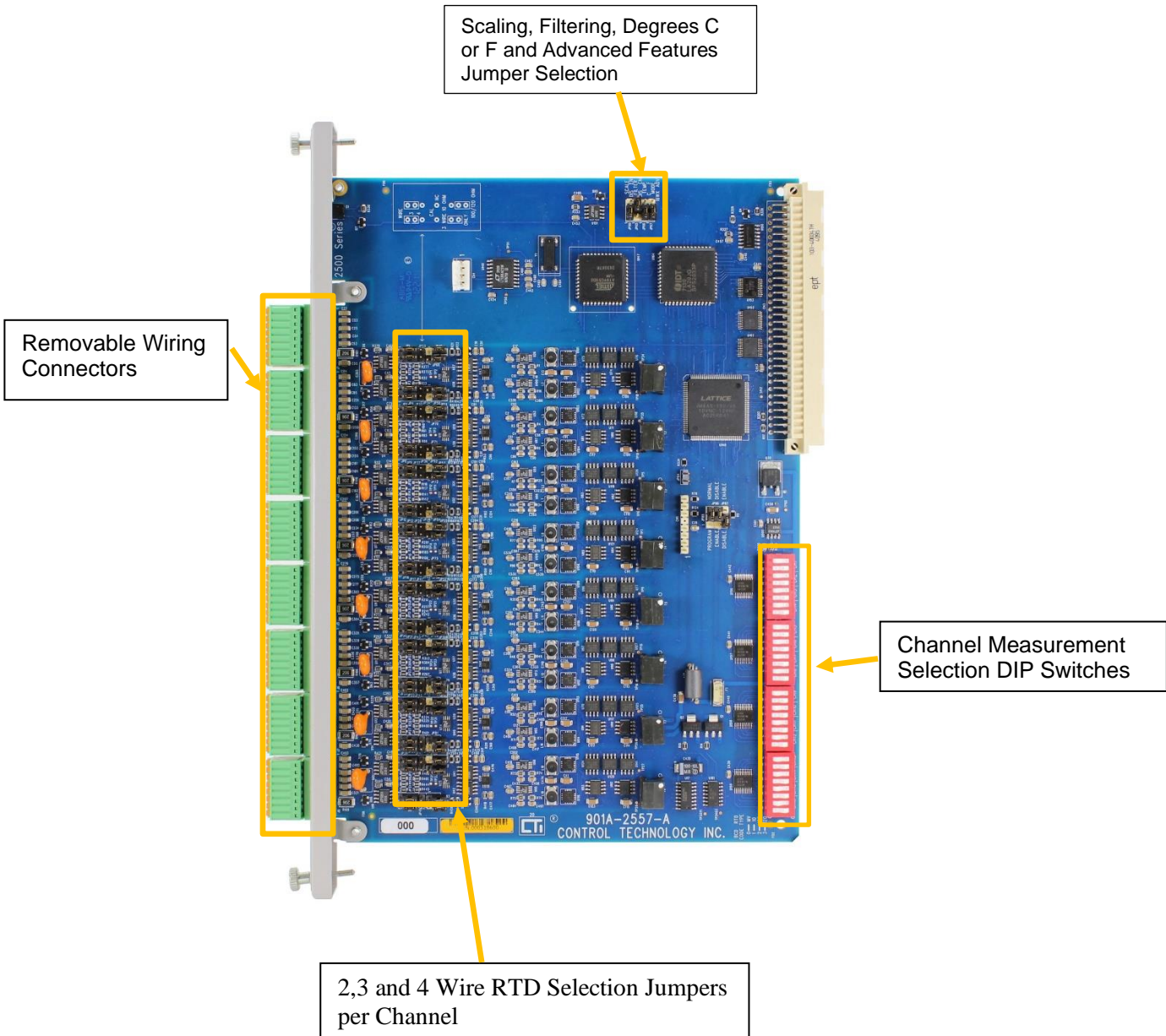

Figure 12 2557-A Module PCB Layout

### 2.5 Inserting the Module Into the I/O Base

Insert the module into the I/O base by carefully pushing the module into the slot. When the module is fully seated in the slot, tighten the captive screws at the top and bottom to hold the module in place. To remove the module from the I/O base, loosen the captive screws, then remove the module from the I/O base. Be careful not to damage the connector card at the back of the module when inserting or removing the module.

**WARNING:**  
 Remove power from the I/O base before inserting or removing a module.

## 2.6 Wiring the Input Connectors

RTD input signals are accepted through a set of 8 pin removable connectors with wire press in terminals located on the front of the module. Consult the RTD manufacturer's recommendations for selecting the input wire type and size. The connector will accept 18 to 30 AWG wire.

Refer to Figure 13 for correct wiring for 2, 3, or 4 wire RTDs to the Model 2557-A. Each channel consists of four press in terminals. Insert wire by using a small screw driver to depress the spring tension lever and then insert the wire. Solid core wires may be pushed in without depressing lever.

Remove wire by depressing spring lever to remove tension and then remove lead wire. (See Figure 12)

The Model 2557-A may compensate for up to 20 Ohm of lead resistance per wire. Use the table in Figure 9 in planning the maximum distance the RTD may be located from the module.

AWG	Ohms/Km	Ohms/Meter	Ohms/Ft	Ohms/1000Ft
18	21.40	0.02140	0.00652	6.52
20	34.10	0.03410	0.01039	10.39
22	54.20	0.05420	0.01652	16.52
24	86.10	0.08610	0.02624	26.24
26	137.00	0.13700	0.04176	41.76
28	218.00	0.21800	0.06645	66.45
30	356.00	0.35600	0.10851	108.51

*Figure 13 Copper Wire Table at 25 Degrees Celsius*

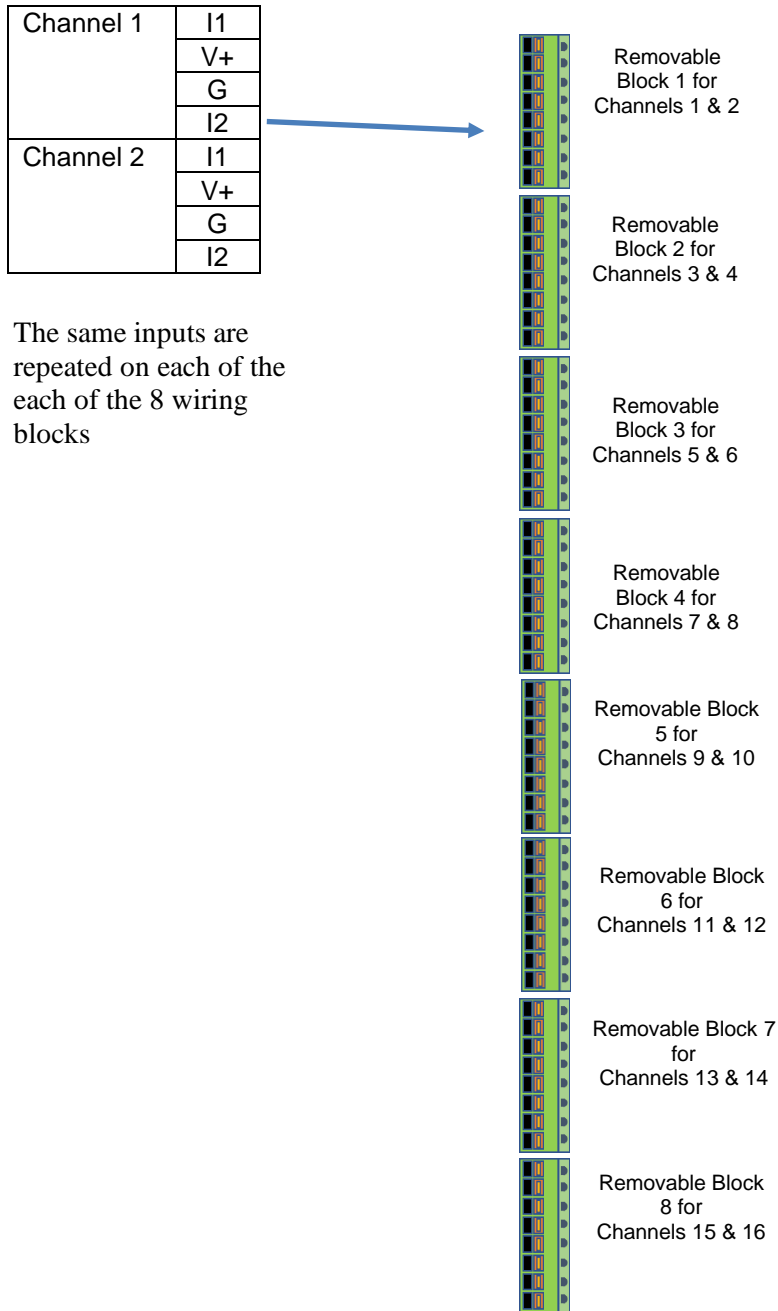

The same inputs are repeated on each of the each of the 8 wiring blocks

*Figure 14 Removable Wiring Connector Wiring Diagram*

**CAUTION:**  
*RTD wires must be of the same gauge for proper lead length compensation.*

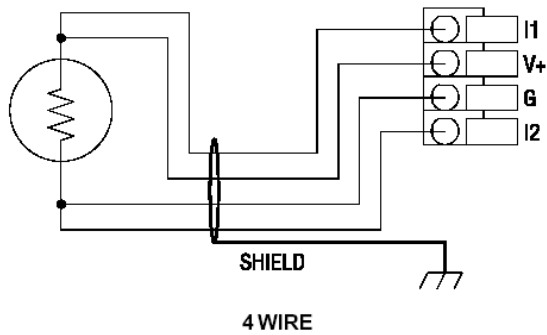
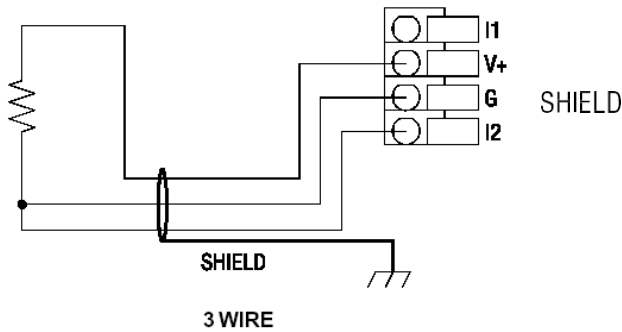
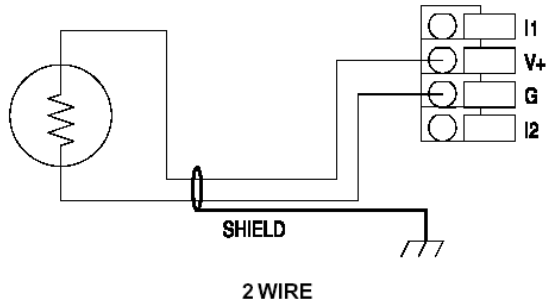
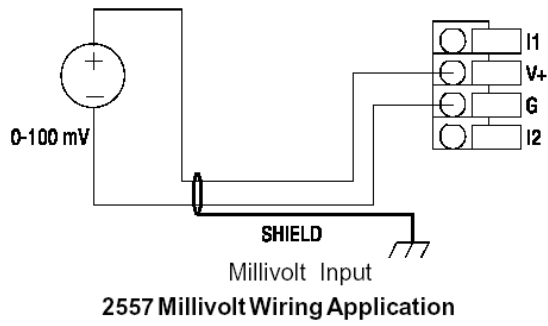

**2557 RTD Wiring Applications**

**CAUTION:**  
 For proper operation, ensure that the 2557-A is not subjected to large temperature gradients during operation.

*Figure 15 Wiring Diagram for 2, 3, 4 Wire RTDs and Millivolt Signals*

### ***2.6.1 Connecting the Shield Wiring***

Control Technology Inc. recommends that all signal wires be shielded twisted-pair with a foil wrap shield and a separate drain wire and that they be installed in a metallic conduit. Use Belden cable 8761 or equivalent which contains foil wrap shield and a separate drain wire. The shield and the foil wrap should be twisted together and should be terminated at only one end. The other end should be left in an open circuit condition. CTI recommends that the shield be terminated at the PLC end of the signal wire. Special components are installed on the module to aid in the rejection of noise.

When entering the industrial cabinet the shield wires should be routed from the main terminal strip all the way to the PLC. Signal leads that do not maintain a shield from the terminal strip to the PLC act as antennas and are susceptible to radiated and conducted emissions in the cabinet. Unprotected cables may introduce measurement errors in the module.

The front connector on the module contains a G terminal which may be used for the shield wire if the installation is in a noise free environment. If the installation is in an extremely noisy environment CTI strongly recommends that the shield wires be terminated to the PLC chassis ground.

CTI has exhaustively tested this product to maximize its ability to reject noise from inductive sources as well as showering arcs, fast transients and other high frequency generators and has determined that the best performance results from connecting all shield wires together at the PLC module and terminating this single wire to the chassis ground with a large current capacity conductor. The PLC chassis should then be wired to earth ground with a large current capacity conductor. CTI recommends using a #8 gauge wire from the PLC chassis to the earth ground connection.

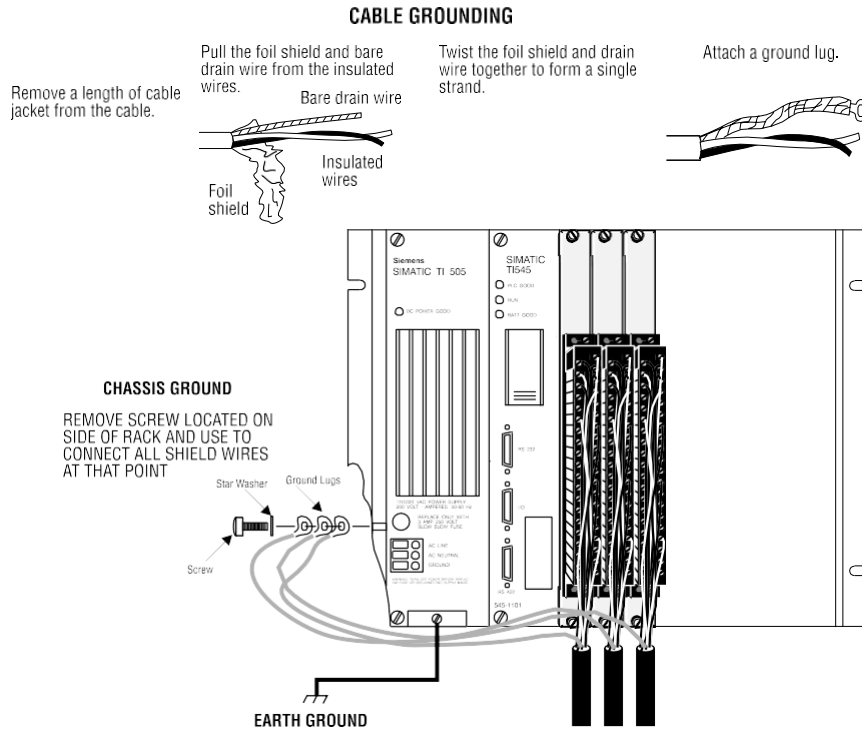

*Figure 16 Cable Grounding*

## 2.7 Checking Module Operation

**NOTE:**

*The 2557-A is isolated channel group to channel group. Each group consist of 2 input channels. Shields within a channel group may be terminated together at either G terminal. CTI recommends that the shield wire be soldered or crimped to the wire connected to the G terminal.*

First turn on the base supply power. If the module diagnostics detect no problems, the status indicator on the front of the module will light. If the status indicator does not light, blinks, (or goes out during operation), the module has detected a failure. For information on viewing failed module status, refer to your Fastrak Workshop user manual. To diagnose and correct a module failure, refer to the next section on troubleshooting.

You must also check that the module is configured in the memory of the PLC. This is important because the module will appear to be functioning regardless of whether it is communicating with the PLC. To view the PLC memory configuration chart listing all slots on the base and the inputs or outputs associated with each slot, refer to your Fastrak Workshop Programming Manual. An example chart is shown in the following figure.



In this example, the 2557-A Module is inserted in slot 1 in I/O base 0. Data for channel 1 appears in word location WX1, data for channel 2 appears in word location WX2, etc. For your particular module, look in the chart for the number corresponding to the slot occupied by the module. If word memory locations appear on this line, then the module is registered in the PLC memory and the module is ready for operation.

I/O MODULE DEFINITION FOR CHANNEL . . . . . 1						BASE . . . . . 00	
I/O SLOT	ADDRESS	X	Y	WX	WY	SPECIAL FUNCTION	
01	0001	00	00	<b>16</b>	00	NO	
02	0000	00	00	00	00	NO	
.	.	.	.	.	.	.	
.	.	.	.	.	.	.	
.	.	.	.	.	.	.	
15	0000	00	00	00	00	NO	
16	0000	00	00	00	00	NO	

*Figure 17 Example I/O Configuration Chart*

If the line is blank or erroneous, re-check the module to ensure that it is firmly seated in the slots. Generate the PLC memory configuration chart again. If the line is still incorrect, contact your local distributor or CTI at 1-800-537-8398 for further assistance.

**NOTE:**

*In advanced Operating Mode the module logs in to the PLC as 16X, 16Y, 32WX and 32WY. Because Profibus will not allow a mixed X,Y,WX, WY slave configuration the Advanced Operating Mode is not supported over Profibus.*

**NOTE:**

*In the event a CTI analog detects an onboard module failure, the module will assert the module fail line and report the module failure in the I/O Status Word, which is reported to the PLC CPU. CTI strongly recommends the user application monitor the **I/O Module Status Words** which are Status Words 11-26 and apply to 2500 Series®. The I/O Module Status Word can be used to report a module failure for an I/O Module in any of the 505 I/O slots. Please refer to 2500 Series® Programming Reference Manual for more information. If a module failure is reported by the status word, the module should be replaced with a working unit and the failed module sent in for repair.*

---

## CHAPTER 3. TROUBLESHOOTING

---

If the module provides improper readings or the status indicator is not on, use the following chart to determine the appropriate corrective action.

SYMPTOM	PROBABLE CAUSE	CORRECTIVE ACTION
Indicator is not lit	Base or PC power is off	Turn base or PC on
	Module not seated	Reseat module in 505 rack
Indicator is blinking	Module is not calibrated	Return module to CTI
Incorrect input values	Wrong addresses for word input	Check program for correct word input addresses
	Not logged-in	Read I/O configuration
	Jumpers and DIP switches not set up	Select correct jumper and DIP switch settings
	Incorrectly calibrated	Return the module to CTI for calibration
	Temperature =WX X10	Adjust scaling in RLL program
Millivolts =WX X100	Select SCALE function with JP90	

*Figure 18 Troubleshooting Matrix*

When it is inconvenient to visually check the status indicator, use the Workshop "Display Failed I/O" or "Show PLC Diagnostics" support functions.

**CAUTION:**  
*The module fuse F1 is not user serviceable. If this fuse is blown, the module has a serious component failure and should be returned to CTI for repair.*

If after consulting the chart above, you are unable to diagnose or solve the problem, contact your local distributor or CTI at 1-800-537-8398 for further assistance.

---

## SPECIFICATIONS

---

**Input Channels:** 16 RTD or Millivolt inputs  
(2 inputs per channel group)

**Module Login:**  
Classic Plus: 16X, 16Y, 32WX, and 32WY  
Classic Mode: 16 WX

**RTD Types:**  
10  $\Omega$  Cu (TCR= 0.00427 W//°)  
100  $\Omega$  Pt (TCR= 0.003850 //°C)  
European DIN 43760  
120 $\Omega$  Ni (TCR= 0.00672 W/W/°C)  
2, 3, and 4 wire modes

**RTD Excitation Current:** 250 micro amp

**Millivolt Input Range:** 0 to 100 mV

**Millivolt Input Impedance:** >1000M $\Omega$ @ DC  
> 10K $\Omega$  @ 16 Hz

**Absolute Millivolt Accuracy:**  
 $\pm$  1.0% full scale or  $\pm$  1.0 mV

**Lead Compensation:** 20  $\Omega$  per lead wire

**Input Overrange Protection:**  
30 VDC or VAC continuous

**Measurement Ranges:**  
10 $\Omega$ Cu -100°C to 260°C (-148°F to 500°F)  
100 $\Omega$ Pt -200°C to 850°C (-328°F to 1562°F)  
120 $\Omega$ Ni -80°C to 260°C (-112°F to 500°F)

**ADC Resolution:** 16 Bits

**Connector:** 8 Removable plug-in connectors  
(Included with the module)

**Wire Gauge:** 18 to 30 AWG

**Module Size:** Single wide

**Backplane Power Consumption:** 4.75 Watts

**Shipping Weight:** 1.5lbs. (0.68kg)

### Additional Product Information:

**Standard Shipping Configuration:**

3 wire 100  $\Omega$  Pt RTD  
Digital Filtering Enabled  
Degrees Centigrade  
Classic Mode 16 WX

Environmental Specifications and UL Agency Certificates of Compliance are available on our website.

Specifications subject to change without notice.

## JUMPER SETTINGS LOG SHEET

CHANNEL NUMBER	3 WIRE / 4 WIRE RTD COMPENSATION JUMPERS			MODE POSITION	DIP SWITCH RECORD <small>RECORD POSITION OF SWITCH FOR EACH CHANNEL</small>		MEASUREMENT TYPE						
							MSB <sub>1</sub>	LSB <sub>1</sub>	MSB <sub>0</sub>	LSB <sub>0</sub>	MSB <sub>0</sub>	LSB <sub>0</sub>	MSB <sub>0</sub>
	CHECK JUMPERS FOR CORRECT COMPENSATION			CIRCLE MODE SELECTED									
1	JP1	JP2	JP68	4 WIRE	3 WIRE	ON	1	OFF	120 OHM	100 OHM	10 OHM	Millivolts	
2	JP3	JP4	JP69	4 WIRE	3 WIRE		2		120 OHM	100 OHM	10 OHM	Millivolts	
3	JP5	JP6	JP70	4 WIRE	3 WIRE		3		120 OHM	100 OHM	10 OHM	Millivolts	
4	JP7	JP8	JP71	4 WIRE	3 WIRE		4		120 OHM	100 OHM	10 OHM	Millivolts	
5	JP9	JP10	JP72	4 WIRE	3 WIRE		5		120 OHM	100 OHM	10 OHM	Millivolts	
6	JP11	JP12	JP73	4 WIRE	3 WIRE		6		120 OHM	100 OHM	10 OHM	Millivolts	
7	JP13	JP14	JP74	4 WIRE	3 WIRE		7		120 OHM	100 OHM	10 OHM	Millivolts	
8	JP15	JP16	JP75	4 WIRE	3 WIRE		8		120 OHM	100 OHM	10 OHM	Millivolts	
9	JP17	JP18	JP76	4 WIRE	3 WIRE		9		120 OHM	100 OHM	10 OHM	Millivolts	
10	JP19	JP20	JP77	4 WIRE	3 WIRE		10		120 OHM	100 OHM	10 OHM	Millivolts	
11	JP21	JP22	JP78	4 WIRE	3 WIRE		11		120 OHM	100 OHM	10 OHM	Millivolts	
12	JP23	JP24	JP79	4 WIRE	3 WIRE		12		120 OHM	100 OHM	10 OHM	Millivolts	
13	JP25	JP26	JP80	4 WIRE	3 WIRE		13		120 OHM	100 OHM	10 OHM	Millivolts	
14	JP27	JP28	JP81	4 WIRE	3 WIRE		14		120 OHM	100 OHM	10 OHM	Millivolts	
15	JP29	JP30	JP82	4 WIRE	3 WIRE		15		120 OHM	100 OHM	10 OHM	Millivolts	
16	JP31	JP32	JP83	4 WIRE	3 WIRE		16		120 OHM	100 OHM	10 OHM	Millivolts	
ALL CHANNELS  1-16	LOGIN MODE JUMPER			DIGITAL FILTERING JUMPER		FAHRENHEIT / CENTIGRADE SELECT		ENGR/SCALE UNITS					
	JP67 LEFT - 16 WX ✓ RIGHT - Advanced			JP65 LEFT - Filtering Disabled ✓ RIGHT - Filtering Enabled ✓		JP66 LEFT - Degrees C ✓ RIGHT - Degrees F		JP90 LEFT - Scale Disabled ✓ RIGHT - Scale Enabled					

Record the configuration jumper settings on this log and circle RTD type selected for future reference. Make additional copies if necessary.

---

***USER NOTES***

---

---

## **LIMITED PRODUCT WARRANTY**

---

CTI warrants that this CTI Industrial Product shall be free from defects in material and workmanship for a period of one (1) year after purchase from CTI or from an authorized CTI Industrial Distributor. This CTI Industrial Product will be newly manufactured from new and/or serviceable used parts which are equal to new in the Product.

Should this CTI Industrial Product fail to be free from defects in material and workmanship at any time during this one (1) year warranty period, CTI will repair or replace (at its option) parts or Products found to be defective and shipped prepaid by the customer to a designated CTI service location along with proof of purchase date and associated serial number. Repair parts and replacement Product furnished under this warranty will be on an exchange basis and will be either reconditioned or new. All exchanged parts or Products become the property of CTI. Should any Product or part returned to CTI hereunder be found by CTI to be without defect, CTI will return such Product or part to the customer.

This warranty does not include repair of damage to a part or the Product resulting from: failure to provide a suitable environment as specified in applicable Product specifications, or damage caused by an accident, disaster, acts of God, neglect, abuse, misuse, transportation, alterations, attachments, accessories, supplies, non-CTI parts, non-CTI repairs or activities, or to any damage whose proximate cause was utilities or utility like services, or faulty installation or maintenance done by someone other than CTI.

Control Technology Inc. reserves the right to make changes to the Product in order to improve reliability, function, or design in the pursuit of providing the best possible Product. CTI assumes no responsibility for indirect or consequential damages resulting from the use or application of this equipment.

**THE WARRANTY SET FORTH ABOVE IN THIS ARTICLE IS THE ONLY WARRANTY CTI GRANTS AND IT IS IN LIEU OF ANY OTHER IMPLIED OR EXPRESSED GUARANTY OR WARRANTY ON CTI PRODUCTS, INCLUDING WITHOUT LIMITATION, ANY WARRANTY OF MERCHANTABILITY OR OF FITNESS FOR A PARTICULAR PURPOSE AND IS IN LIEU OF ALL OBLIGATIONS OR LIABILITY OF CTI FOR DAMAGES IN CONNECTION WITH LOSS, DELIVERY, USE OR PERFORMANCE OF CTI PRODUCTS OR INTERRUPTION OF BUSINESS, LOSS OF USE, REVENUE OR PROFIT. IN NO EVENT WILL CTI BE LIABLE FOR SPECIAL, INCIDENTAL, OR CONSEQUENTIAL DAMAGES.**

SOME STATES DO NOT ALLOW THE EXCLUSION OR LIMITATION OF INCIDENTAL OR CONSEQUENTIAL DAMAGES FOR CONSUMER PRODUCTS, SO THE ABOVE LIMITATIONS OR EXCLUSIONS MAY NOT APPLY TO YOU.

THIS WARRANTY GIVES YOU SPECIFIC LEGAL RIGHTS, AND YOU MAY ALSO HAVE OTHER RIGHTS WHICH MAY VARY FROM STATE TO STATE.

---

## **REPAIR POLICY**

---

In the event that the Product should fail during or after the warranty period, a Return Material Authorization number (RMA) can be requested verbally or in writing from CTI main offices. Whether this equipment is in or out of warranty, a Purchase Order number provided to CTI when requesting the RMA number will aid in expediting the repair process. The RMA number that is issued and your Purchase Order number should be referenced on the returning equipment's shipping documentation. Additionally, if under warranty, proof of purchase date and serial number must accompany the returned equipment. The current repair and/or exchange rates can be obtained by contacting CTI's main office at 1-800-537-8398.

When returning any module to CTI, follow proper static control precautions. Keep the module away from polyethylene products, polystyrene products and all other static producing materials. Packing the module in its original conductive bag is the preferred way to control static problems during shipment. **Failure to observe static control precautions may void the warranty.** For additional information on static control precautions, contact CTI's main office at 1-800-537-8398.