

**CTI 2556 / 2556-A / 2557 / 2557-A
SIXTEEN CHANNEL ADVANCED FUNCTION
PROGRAMMING REFERENCE MANUAL**

**Version 1.6
CTI Part #062-00177-016**



**Copyright © 2005-2020 Control Technology Inc.
All rights reserved.**

This manual is published by Control Technology Inc., 5734 Middlebrook Pike, Knoxville, TN 37921. This manual contains references to brand and product names which are tradenames, trademarks, and/or registered trademarks of Control Technology Inc. Siemens® and SIMATIC® are registered trademarks of Siemens AG. Other references to brand and product names are tradenames, trademarks, and/or registered trademarks of their respective holders.

DOCUMENT DISCLAIMER STATEMENT

Every effort has been made to ensure the accuracy of this document; however, errors do occasionally occur. CTI provides this document on an "as is" basis and assumes no responsibility for direct or consequential damages resulting from the use of this document. This document is provided without express or implied warranty of any kind, including but not limited to the warranties of merchantability or fitness for a particular purpose. This document and the products it references are subject to change without notice. If you have a comment or discover an error, please call us at +1.865.584.0440

PREFACE

This *Programming and Reference Manual* is provided to document the advanced software functionality available in the sixteen channel single-wide analog and temperature modules for the SIMATIC® 505 PLC family. These products feature an advanced operating mode that allows for preprocessing of the analog and temperature measurements directly on the module before being transferred to the PLC. The functions supported include scaling to engineering units, low and high alarms, peak and valley hold, process averaging and digital filtering. This manual covers the following products:

Model 2556 / 2556-A Thermocouple Input
Model 2557 / 2557-A RTD Input

IMPORTANT NOTE: In the remainder of this Manual, where we refer to 2556, it should be understood to apply to 2556 and 2556-A. Where we refer to 2557, it should be understood to apply to 2557 and 2557-A.

This *Programming and Reference Manual* is organized as follows:

Chapter 1 provides a description of the advanced features as well as the hardware configuration changes required on the module and in the PLC I/O configuration.

Chapter 2 details the I/O configuration structure and the configuration of data to program the advanced features in the 2556/2557 module.

Chapter 3 provides sample relay ladder programs that may be used to set up the module in the PLC.

Chapter 4 includes timing constraints and additional information for each function enabled.

Chapter 5 is a guide to troubleshooting.

USAGE CONVENTIONS

NOTE:

Notes alert the user to special features or procedures.

CAUTION:

Cautions alert the user to procedures which could damage equipment.

WARNING:

Warnings alert the user to procedures which could damage equipment and endanger the user.

STATEMENT OF PRODUCT COMPATIBILITY:

The 2556 and 2557 16-point I/O modules are compatible with all of the SIMATIC® PLCs including the 535, 545 and 555 except for the Model 525. The Model 525 will not support the high density mode that is required for the advanced software functions.

TABLE OF CONTENTS

PREFACE.....	v
USAGE CONVENTIONS.....	vii
TABLE OF FIGURES.....	xi
CHAPTER 1. Advanced Software Functions 2556/2557 I/O Modules.....	1
1.1 Overview of the Advanced Functions.....	1
1.2 Setting the Module Configuration Jumper.....	3
1.3 Logging the Module in the PLC I/O Configuration Memory.....	4
CHAPTER 2. The Internal Register Structures.....	5
2.1 A Description of the I/O Registers.....	5
2.2 The Input Registers.....	5
2.3 The Output Registers.....	6
2.4 The Control Registers.....	7
2.4.1 Inputs.....	8
2.4.2 Outputs.....	9
2.5 Loading the Data into the 2556/2557 Module.....	11
CHAPTER 3. Loading the Programs into the I/O Module.....	15
3.1 A Sample Relay Ladder Program for Loading the Data.....	15
CHAPTER 4. Timing Considerations and Additional Information.....	17
4.1 Timing Constraints When Using Advanced Functions.....	17
4.2 Additional Information about Each Function.....	18
4.2.1 Default Values.....	18
4.2.2 Degrees Centigrade or Degrees Fahrenheit.....	19
4.2.3 Scaling.....	19
4.2.4 Alarm Setpoints.....	19
4.2.5 Digital Filtering.....	20
4.2.6 Averaging.....	21
4.2.7 Peak and Valley Hold.....	21
4.2.8 Peak and Valley Hold Reset.....	22
4.2.9 Flag Bits.....	22
4.2.10 Advanced Function Precedence.....	23
CHAPTER 5. Troubleshooting.....	25
5.1 Troubleshooting the System.....	25

APPENDIX A. I/O Register Quick Reference.	27
APPENDIX B. V or K Memory Configuration Tables.	29
APPENDIX C. Addressing Worksheet	31
APPENDIX D. Items Unique to the Model 2556.	33
APPENDIX E. Items Unique to the Model 2557.	35
LIMITED PRODUCT WARRANTY	39
REPAIR POLICY.	41

TABLE OF FIGURES

Figure 1	<i>Configuring the Model 2556 Module for Advanced Features.</i>	3
Figure 2	<i>Configuring the Model 2557 Module for Advanced Features.</i>	3
Figure 3	<i>Model 2556/2557 I/O Configuration Chart.</i>	4
Figure 4	<i>Input and Output Register Offsets.</i>	5
Figure 5	<i>Input Channel Data.</i>	5
Figure 6	<i>Input Flag Bits.</i>	6
Figure 7	<i>Peak/Valley Hold Input Words.</i>	6
Figure 8	<i>Output Data Registers.</i>	7
Figure 9	<i>Function Enable Bits.</i>	7
Figure 10	<i>Discrete Handshake Inputs.</i>	8
Figure 11	<i>Data Identification Bits.</i>	9
Figure 12	<i>Data Transfer Control Bits.</i>	10
Figure 13	<i>Data Loading Process.</i>	11
Figure 14	<i>Sample Low and High Alarm Setpoints.</i>	12
Figure 15	<i>The Module_Ready Bit.</i>	12
Figure 16	<i>Identifying the Data Being Transferred.</i>	13
Figure 17	<i>The Data_Ready Bit.</i>	13
Figure 18	<i>Enabling the Functions Loaded.</i>	14
Figure 19	<i>Loading the Enable Bits.</i>	14
Figure 20	<i>Startup Relay Ladder Logic.</i>	15
Figure 21	<i>Timing Overhead for Functions Enabled.</i>	17
Figure 22	<i>Default Function Values.</i>	18
Figure 23	<i>Default Function Values for Models 2556 and 2557.</i>	18
Figure 24	<i>Peak/Valley Truth Table.</i>	21
Figure 25	<i>Peak/Valley Reset Truth Table.</i>	22
Figure 26	<i>Mapping Bit Position to Channel Number.</i>	22
Figure 27	<i>Troubleshooting Flow Diagram.</i>	26
Figure 32	<i>Open Thermocouple Bits.</i>	33
Figure 33	<i>Open RTD Status Bits.</i>	35

CHAPTER 1. Advanced Software Functions 2556/2557 I/O Modules

As PLC control systems become more complex, the need for real-time processing of analog signals is needed at the I/O level. Current implementations using the SIMATIC® 505 PLCs utilize analog alarm blocks and/or special function programs within the controller. The 2556/2557 series of analog input modules from Control Technology Inc. can reduce the program complexity and scan time by performing this signal processing in the module. Scaling, alarming, peak/valley hold, digital filtering, and averaging are available on a per-channel basis and are selected through a simple PLC configuration routine. The module logs in as 16X / 16Y / 32WX / 32WY when these advanced functions are enabled. A jumper on the module selects the standard 16 WX login or the high-density advanced function interface.

STATEMENT OF PRODUCT COMPATIBILITY:

The 2556 and 2557 16-point I/O module is compatible with all of the SIMATIC® PLCs including the 535, 545 and 555 except for the Model 525. The Model 525 will not support the high density mode that is required for the advanced software functions.

1.1 Overview of the Advanced Functions

Each of these functions can be selected on a per-channel basis, and each channel can have any function in any combination, e.g. alarming on a scaled value which is digitally filtered and set for peak hold. (See Chapter 4 for timing considerations.)

Scaling - Each channel can be configured with low and/or high scale value. A flowmeter that outputs 0mA @ 5cfm and 20mA @ 50cfm would have a low scale of 5 and a high scale of 50. An operator interface attached to the PLC could then read the analog values directly in engineering units without having to run a Special Function program to Scale the input.

Alarming - Each channel can be assigned a low and/or high alarm value. No analog alarm blocks are needed in the PLC. Alarming occurs real-time as the signal is processed by the module. Two WX words are used to indicate high and low alarm conditions (bit 1 = channel 16, etc.). A third WX word is the logical OR of the high and low alarms.

Peak/valley hold - The peak or valley of a rapidly changing analog signal has been impossible to detect unless an external circuit was used. The 2556/2557 module makes possible the detection of a peak or valley and holds that value until reset by the PLC. The peak/valley measurement is available to the PLC at the same time as the currently measured analog value.

Averaging - This option is used to "clean up" a signal that is at a steady state, e.g. a sensor riding on a liquid tank with ripples. The user specifies how many signals scans to average and this value is presented to the PLC.

Digital filtering - This has the effect of a moving average operation (actually it is an Infinite Impulse Response filter), and is useful to smooth out the high frequency noise on a changing analog signal. Chapter 4 gives the details.

All of these advanced function options are designed to be stored in the PLC in a V-memory or K-memory table and downloaded to the module. The advantages of this method vs. a communications port on the module are greater flexibility, easier maintenance procedures and reduced documentation. The PLC can change any function "on the fly" if changing process conditions require, e.g. a process needs tighter control therefore narrower alarm limits. Any replacement module can be downloaded from the PLC which eliminates finding a cable, laptop computer and the most recent documentation.

1.2 Setting the Module Configuration Jumper

Before beginning to use the advanced mode of the 2556/2557 module, all of the hardware functions such as voltage range input levels, current input mode, unipolar or bipolar level etc. should be set up with the appropriate Installation and Operations Guide.

Model #	Part #
2556	062-00178
2557	062-00179

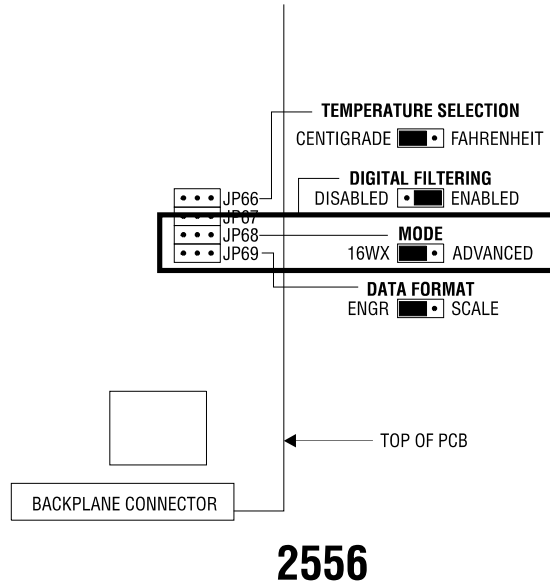

Figure 1 *Configuring the Model 2556 Module for Advanced Features*

1.3 Logging the Module in the PLC I/O Configuration Memory

First turn on the base power supply. If the module diagnostics detect no problems, the status indicator on the front of the module will light. If the status indicator does not light, blinks (or goes out during operation), the module has detected a failure. For information on viewing failed module status, refer to your SIMATIC® TISOFT user manual. To diagnose and correct a module failure, refer to the section on troubleshooting.

You must also check that the module is configured in the memory of the PLC. This is important because the module will appear to be functioning regardless of whether it is communicating with the PLC. To view the PLC memory configuration chart listing all slots on the base and the inputs or outputs associated with each slot, refer to your SIMATIC® TISOFT Programming Manual. An example chart is shown in the following figure. When the module is properly logged in to the PLC as a high density discrete and analog module the configuration will be 16X, 16Y, 32WX, and 32WY registers.

In this example, the Model 2556/2557 module is inserted in slot 1 in I/O base 0. The first X point is assigned the first I/O address. In this example the I/O assignments are: X1 . . X16, Y17 . . Y32, WX33 . . WX64, WY65 . . WY96. For your particular module, look in the chart for the number corresponding to the slot occupied by the module. If word memory and discrete locations appear on this line, then the module is registered in the PLC memory and the module is ready for operation.

If the line is blank or erroneous, re-check the module to ensure that it is firmly seated in the slots. Generate the PLC memory configuration chart again. If the line is still incorrect, contact your local distributor or CTI at 1-800-537-8398 for further assistance.

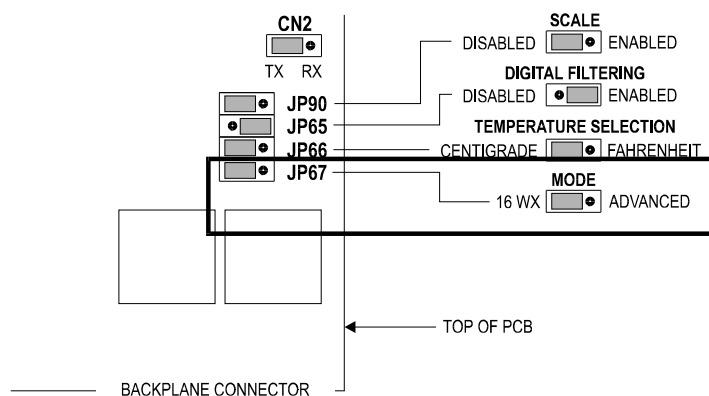

2557

Figure 2 Configuring the Model 2557 Module for Advanced Features

CHAPTER 2. The Internal Register Structures

2.1 A Description of the I/O Registers

The 2556/2557 series of modules in the high density mode login to the PLC as 32 WX input registers, 32 WY output registers and 16 X and 16 Y discrete inputs and outputs. This high density configuration will provide support for reading the raw data, the processed data and writing the configuration data to the module. Refer to Appendix A for a one-page summary of I/O assignments.

Depending on the starting login address, the location of the corresponding registers will be as follows:

I/O MODULE DEFINITION FOR CHANNEL ... 1 BASE 00						
SLOT	ADDRESS	X	Y	WX	WY	SPECIAL FUNCTION
01	... 0001	16	16	32	32	NO
02	... 0000	00	00	00	00	NO
15	... 0000	00	00	00	00	NO
16	... 0000	00	00	00	00	NO

Figure 3 Model 2556/2557 I/O Configuration Chart

2.2 The Input Registers

The word input content of the module consists of 32 WX input registers. These registers will present the raw measured data and the processed data to the PLC.

WX 33 - WX 48 contains the converted data in engineering units for the sixteen input channels.

Starting PLC Address	1	105
X registers begin	1	105
Y registers offset 16	17	121
WX registers offset 32	33	137
WY registers offset 64	65	169

Figure 4 *Input and Output Register Offsets*

WX 33	Channel 1	Conversion data
.		
WX 48	Channel 16	Conversion data

Figure 5 *Input Channel Data*

For Alarms:	WY 65	Channel 1	Low alarm setpoint
	.	.	.
	WY 80	Channel 16	Low alarm setpoint
	WY 81	Channel 1	High alarm setpoint
For Scaling:	.	.	.
	WY 96	Channel 16	High alarm setpoint
	WY 65	Channel 1	Scaling low setpoint
	.	.	.
Digital Filtering:	WY 80	Channel 16	Scaling low setpoint
	WY 81	Channel 1	Scaling high setpoint
	.	.	.
	WY 96	Channel 16	Scaling high setpoint
Averaging:	WY 65	Channel 1	Settling time
	.	.	.
Averaging:	WY 80	Channel 16	Settling time
	.	.	.
Averaging:	WY 81	Channel 1	Average sample counts
	.	.	.
Averaging:	WY 96	Channel 16	Average sample counts
	.	.	.

Figure 8 *Output Data Registers*

After the values are loaded to the 2556/2557 module then, WY registers are used as follows:

WY 65	Channel 1-16	Low alarm enable bits
WY 66	Channel 1-16	High alarm enable bits
WY 67	Channel 1-16	Scaling enable bits
WY 68	Channel 1-16	Digital filtering enable bits
WY 69	Channel 1-16	Averaging enable bits
WY 70	Channel 1-16	Peak hold enable bits
WY 71	Channel 1-16	Valley hold enable bits
WY 72	Channel 1-16	Fahrenheit/Centigrade select bits
WY 73	Channel 1-16	Peak hold reset bits
WY 74	Channel 1-16	Valley hold reset bits
WY 75	Channel 1-16	Averaging reset with new value bits
WY 76-96		Not used

Figure 9 *Function Enable Bits*

2.4 The Control Registers

The control registers (X and Y discrete I/O points) are the handshake bits and steering logic used to load data into the 2556/2557 module and to request special operations from the 2556/2557 module. These registers consist of the discrete inputs and outputs of the module.

2.4.1 Inputs

The 2556/2557 input module uses a total of 5 discrete inputs in advanced mode. Four of the inputs are used as handshake bits from the module to the PLC to indicate that alarm levels, scaling data, filter and averaging values and function enable bits have been transferred successfully to the module.

The remaining input X16 is used by the 2556/2557 module to inform the PLC that the module is ready to accept data.

Before any transfers are made to the 2556/2557 module the relay ladder program should examine the state of this input. When the input is true, the loading operation may begin.

	Input #	
X	1	Alarm_Acknowledge
1		No alarm levels loaded
0		Alarm levels loaded
X	2	Scaling_Acknowledge
1		No scaling values loaded
0		Scaling values loaded
X	3	Filter/Sample_Acknowledge
1		No filter or sample values loaded
0		Filter/sample values loaded
X	4	Function Bits_Acknowledge
1		No functions enabled
0		Functions enabled
X	5	Module_Relay Flag
1		Busy
0		Ready for transfer

Figure 10 *Discrete Handshake Inputs*

2.4.2 Outputs

The output discrete points consist of Y 17 - Y 32.

Y 17 - Y 19 are used to identify the data being transferred. As data is loaded to the 2556/2557 module, the state of these bits identifies the type of data being transferred. The 2556/2557 module decodes these bits and processes the data accordingly.

Y 19	Y 18	Y 17	Data Transfer Type
0	0	0	No operation
0	0	1	Function enable bits
0	1	0	Low/High alarm setpoint values
0	1	1	Scaling low/high values
1	0	0	Filtering time constant/Number of averages

Figure 11 *Data Identification Bits*

In addition Y 27 - Y 32 are used to reset averaging, reset valley hold values, reset peak hold values, read peak or valley values, read flags, and to write data to the 2556/2557 module.

Y 27	Averaging reset
1	Resets averaging on all channels to new values loaded
Y 28	Valley hold reset
1	Reset valley hold
Y 29	Peak hold reset
1	Reset peak hold
Y 30	Read peak hold/valley hold
0	Read valley hold values
1	Read peak hold value
Y 31	Read peak hold/valley hold or Read flags
0	Read flags
1	Read peak hold/valley hold values
NOTE: In operation the state of Y 31 determines whether WX 49- WX 64 return peak/valley data or the flag bits defined in Section 2.3. If Y 31 is turned on then the type of data (valley hold or peak hold) is then selected with Y 30.	
Y 32	Data_Ready , PLC to module data ready flag
0	no data
1	data ready to transfer

Figure 12 *Data Transfer Control Bits*

2.5 Loading the Data into the 2556/2557 Module

The process by which data is loaded into the 2556/2557 series module consist of the following:

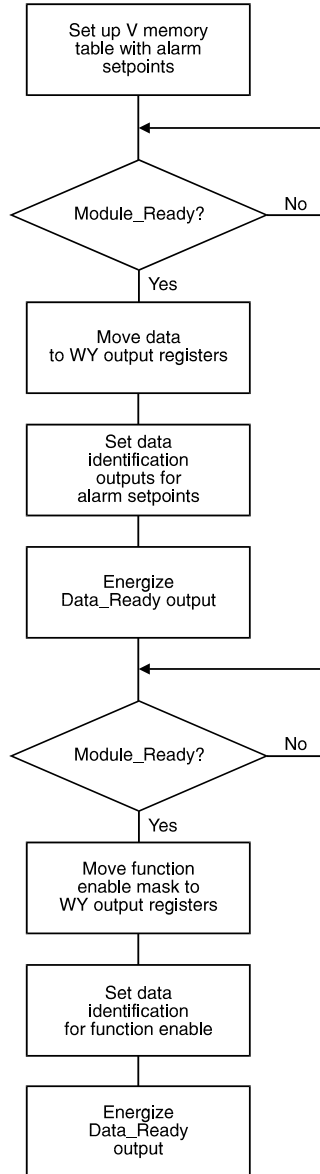

Figure 13 *Data Loading Process*

1. V or K memory tables are constructed with the scaling, alarm setpoints, filtering and averaging units. In the example below low alarm and high alarm setpoints are loaded for each channel from V1 through V32. V1 - V16 contain the low alarm setpoints for channels 1-16 and V17 - V32 contain the

V 1	100	V 17	20,100
V 2	200	V 18	20,200
V 3	300	V 19	20,300
V 4	400	V 20	20,400
V 5	500	V 21	20,500
V 6	600	V 22	20,600
V 7	700	V 23	20,700
V 8	800	V 24	20,800
V 9	900	V 25	20,900
V 10	1000	V 26	21,000
V 11	1100	V 27	22,000
V 12	1200	V 28	23,000
V 13	1300	V 29	24,000
V 14	1400	V 30	25,000
V 15	1500	V 31	26,000
V 16	1600	V 32	27,000

Figure 14 *Sample Low and High Alarm Setpoints*

high alarm setpoints for channels 1-16.

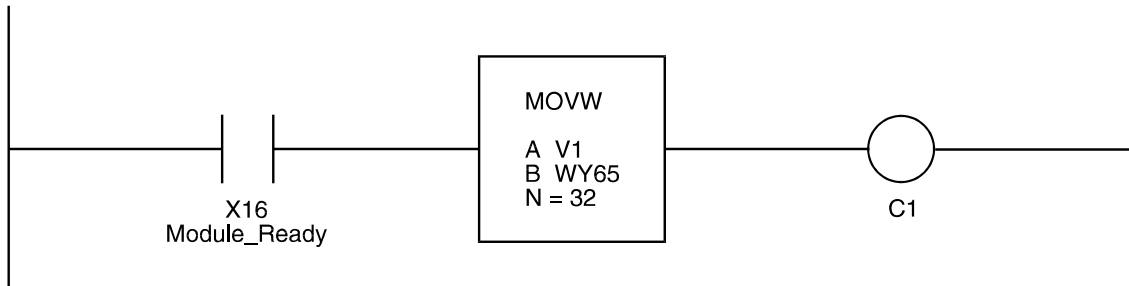

Figure 15 *The Module_Ready Bit*

2. By monitoring the state of the Module_Ready flag, data is moved to the WY output registers.

3. The data identification outputs Y 19 - Y 17 are set according to the data being transferred. These

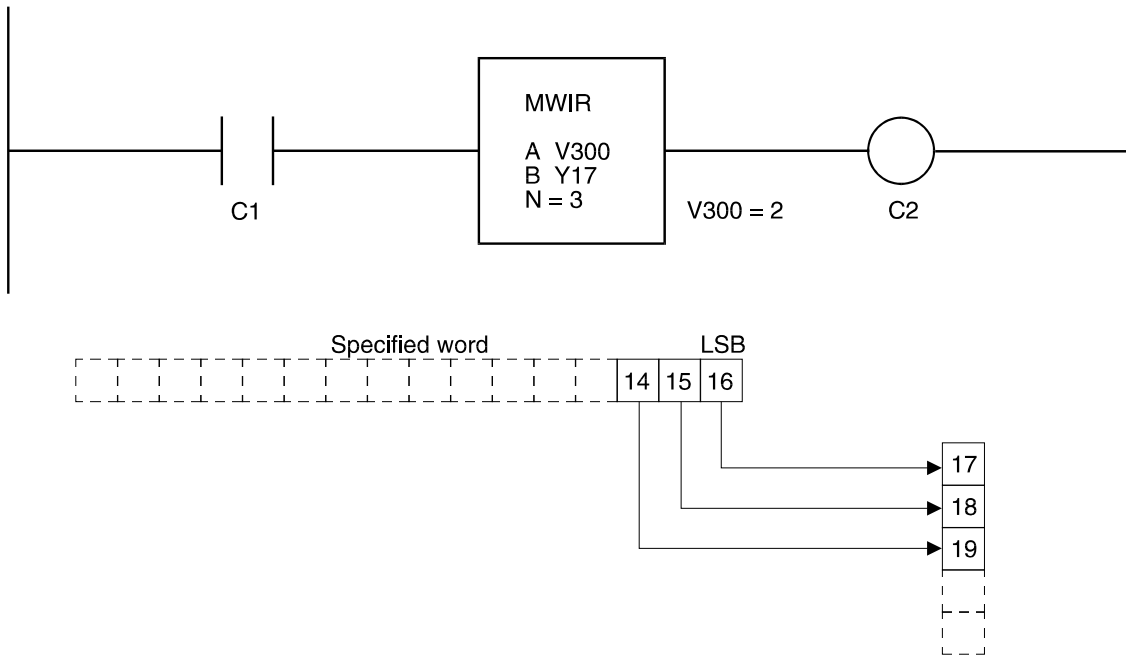

Figure 16 *Identifying the Data Being Transferred*

are decoded by the module in order to distinguish the type of data being loaded.



Figure 17 *The Data_Ready Bit*

4. Y 32 Data_Ready is energized to transfer the word data into the module.

5. The functions are enabled with the enable bits. WY 65 and WY 66 are set to all 1's with a MOVW

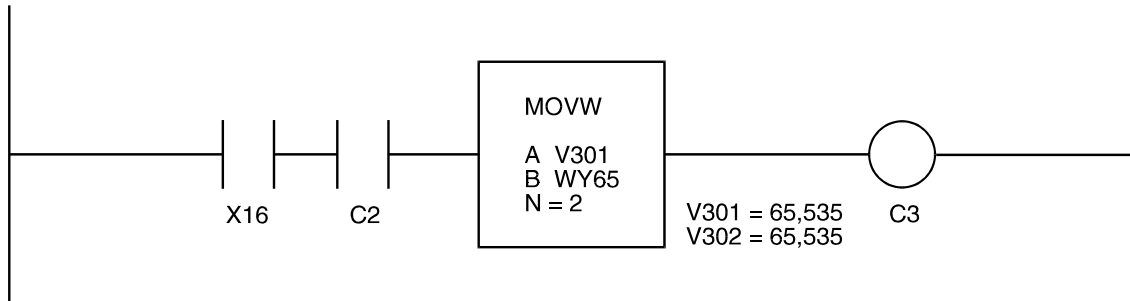

Figure 18 *Enabling the Functions Loaded*

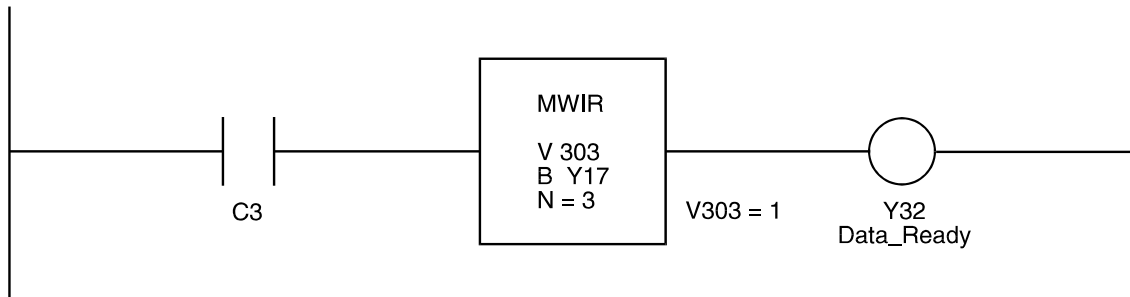

Figure 19 *Loading the Enable Bits*

instruction.

6. With the Data_Ready bit, data is transferred with Y 32.

CHAPTER 3. Loading the Programs into the I/O Module

Before entering relay ladder logic in the PLC, utilize the worksheets included in Appendix B and C to ensure a successful installation and start-up.

The following sample ladder programs are provided to demonstrate how the data is loaded into the 2556/2557 module. Each channel is enabled for all functions supported.

This sample RLL loads the module with alarm, scaling, filtering, averaging, and function enable bits. V200 manipulation is left to the programmer.

3.1 A Sample Relay Ladder Program for Loading the Data

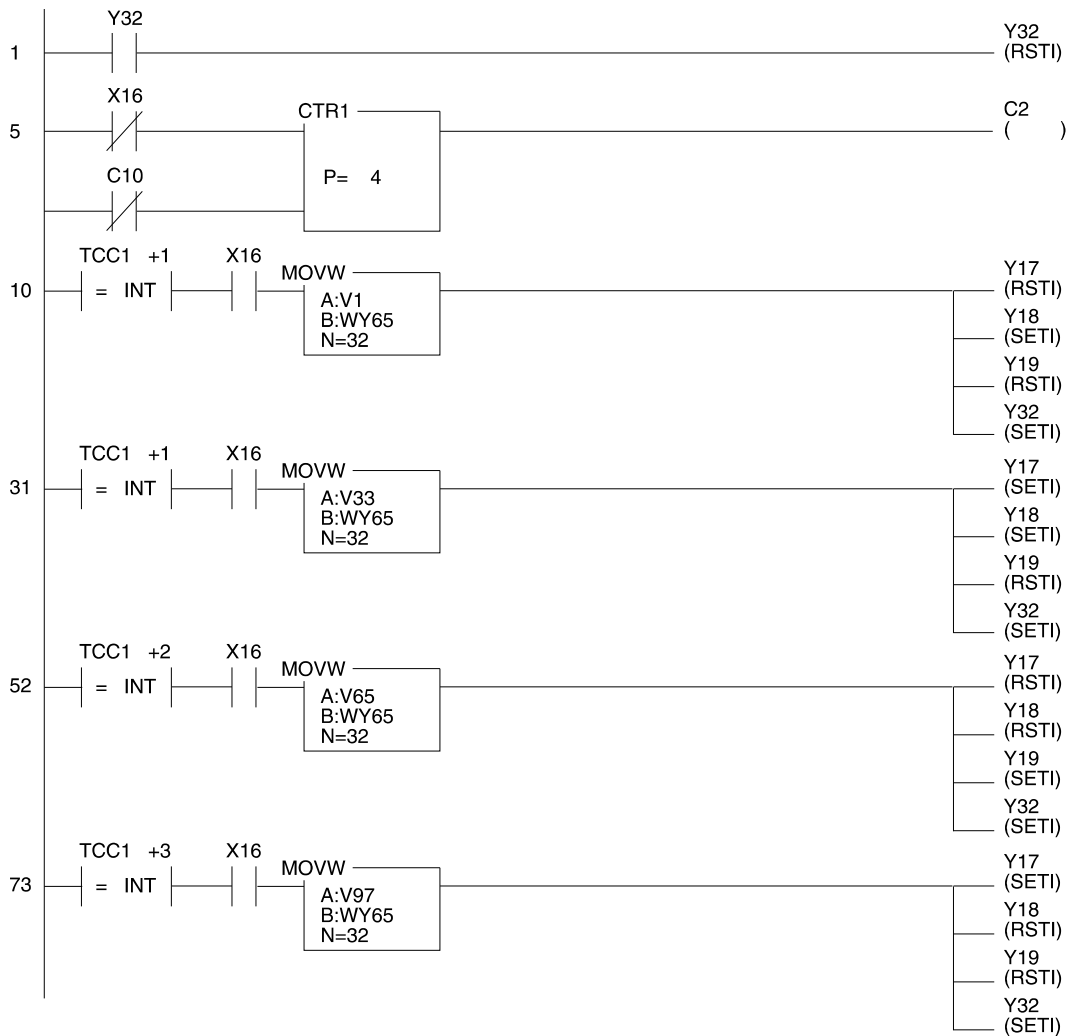

Figure 20 Startup Relay Ladder Logic

The configuration example ladder program sequences through the transfer of all configuration data to the module.

The first rung in the example resets Y32 if Y32 was turned ON on the previous scan. This should be done at the beginning of the ladder scan.

The second rung is a counter that controls loading of the WY registers with configuration data.

When the counter is reset, the current count is equal to zero. If X16 is ON, the WY registers are loaded with Low and High Alarm data from V1 through V32. Y12, Y18, and Y19 are set to the appropriate bit pattern to identify Low/High Alarms Values and Y32 is set ON.

After the WY registers have been read by the module, X16 is turned OFF which bumps the counter current value to 1. When the module has finished processing the Low/High Alarm data, X16 is turned ON and the next MOVW instruction is executed. This rung moves Low/High Scaling values from V33 through V64.

After this data is processed by the module, the next MOVW instruction is executed which loads the WY registers with Filtering Time Constants and Average Sample Counts from V65 through V96.

After this data is processed by the module, the last MOVW instruction is executed which loads the Function Enable Bits into the WY registers from V Memory beginning at V97.

When this transfer is complete, the counter current value is now equal to 4 which is the preset value and the configuration sequence is complete. Another configuration sequence can be initiated by toggling the counter reset bit to reset the counter.

CHAPTER 4. Timing Considerations and Additional Information

Without enabling any of the advanced features the 2556/2557 module will update all 16 points in less than 6 mSec. With all functions enabled for all 16 points the 2556/2557 will update all 16 channels in less than 56 mSec. Each function has a specific overhead associated with it and your application should consider the time delays to ensure that there is adequate time allowed for the processing of data.

4.1 Timing Constraints When Using Advanced Functions

Below is a chart of the overhead required for all 16 channels when each of the advanced functions is

Functions Enabled 32 WX and 32 WY mode 16 X and 16 Y	Time for all 16 Channels	
None	6.5	msec
Low alarm	7.73	msec
High alarm	7.73	msec
Scaling	27.1	msec
Offset mode	27.1	msec
Filtering	8.97	msec
Averaging	7.85	msec
Averaging reset (16 channels)	41.8	msec
Peak hold	7.65	msec
Valley hold	7.65	msec
16 WX mode		
No digital filtering	5.80	msec
Filtering enabled	8.20	msec

Figure 21 *Timing Overhead for Functions Enabled*

enabled. Operations such as scaling and offset mode require the most amount of time due to the multiplications and division in the microcomputer.

4.2 Additional Information about Each Function

4.2.1 Default Values

There are default values for every function that is supported. If no data is transferred to the module and the enable bits for a function are set and written to the module then the default values will be used.

NOTE:
No matter what functions are enabled the actual hardware data from the I/O channel is always present in WX 33 - WX 48.

Function Enabled	Low Default Value	High Default Value
Alarm Setpoints	1000	31,000
Scaling engineering units	0	32,000
Offset mode 4-20 mA	6400	32,000
Filtering time constants	250 msec	
Averaging	20 averages	
Peak hold	0	0
Valley hold	0	0

Figure 22 *Default Function Values*

Function Enabled	Low Default Value	High Default Value
Alarm Setpoints	50	200
Scaling engineering units	0	100
Filtering time constants	250 msec	
Averaging	20 averages	
Peak hold	0	0
Valley hold	0	0

Figure 23 *Default Function Values for Models 2556 and 2557*

4.2.2 Degrees Centigrade or Degrees Fahrenheit

In advanced mode the selection of degrees C or F is controlled by the information stored and transferred to the module at WY72. The default parameters are all zeroes, which will cause the 2556/2557 module to return the value in degrees Centigrade x10. To select degrees F for the module write a value of FFFF Hex to WY72 and use the documented transfer procedure setting the data identification bits Y17, Y18 and Y19 to 1, 0, 0, (See Appendix A). The corresponding indication as to the reported units (°C or °F) selected is found in WX57. Once the user has selected °C or °F in WY72, WX57 confirms the selected unit of measurement. In WX57 a bit value of 0 equals units in °C and a bit value of 1 indicates units are in °F.

NOTE:

Temperature is reported in °Cx10 or °Fx10, depending on user selection.

4.2.3 Scaling

Numerical Range:

All numbers used for scaling are expressed as signed integers.

The numerical range for scaling is ± 32767 . If a value of -32768 is loaded into the module then the value will be adjusted in the module to -32767.

Arithmetic Overflow:

Scaling operations may result in arithmetic overflow. Errors of this kind for each channel may be detected with the WX 54 Arithmetic overflow bits.

Overflow conditions can occur during normalization of the input value. If the input word reaches +32767 or -32767 before the ADC (analog to digital converter) saturates then an overrange condition will occur and the overrange bit for that channel will be set.

In a scaling operation if the result of scaling forces the value to the PLC to exceed 32767 the overrange bit for that channel will be set.

During an overflow condition the value to the PLC will default to ± 32767 and there will be no rollover of data. That is the data will not return to zero and beyond.

4.2.4 Alarm Setpoints

Numerical Range:

All numbers used for alarm setpoints are expressed as signed integers. The numerical range for scaling is ± 32767 . If a value of -32768 is loaded into the module then the value will be adjusted in the module to -32767.

4.2.5 Digital Filtering

Digital filtering time is the settling time to within 1 LSB of the analog to digital converter on the module. (Often digital filtering is specified as a time constant in milliseconds. With a time constant specification it will take the input 4 to 5 time constants to reach 99% of the final value.) The value entered is the actual settling time.

NOTE:

In the 2556/2557 modules the value used in digital filtering is not a time constant but is the settling time for the system to reach the full resolution of the ADC converter.

When filtering is enabled the actual resolution of the module is a full 16 bits. The filtering function performs a dithering operation for the least significant bits.

Default Filter Settling Time:

If the digital filtering bits are enabled via the WY register and the Y 32 output and no settling time values are written to the module then the default digital filter settling time of 250 mSec will automatically be used.

Filtering and Alarms:

If filtering is enabled then the filtered data will be used for alarm comparisons; that is data will first pass through the digital filter and its associated settling time and then be compared to any low or high alarm setpoint. This will prevent alarm conditions that are attributable to noise.

Changing the Settling Time:

When new filter data is written to the 2556/2557 module, the microcomputer must be recompute the filter time constants. This operation takes 25 mSec and no new data is written to the PLC during this time.

Numerical Range:

Values loaded into the 2556/2557 module for digital filtering are expressed as 16 bit unsigned

NOTE:

Signed integers will be interpreted as unsigned values.

integers

0-65535 in units of milliseconds.

4.2.6 Averaging

Exclusivity:

If averaging and filtering are both enabled, alarming is exclusive of averaging. This means that after the data is filtered it is compared against alarm setpoints and then averaged.

Numerical Range:

Values loaded into the 2556/2557 module for averaging are expressed as 16 bit unsigned integers 1-65535 in units of number of samples. Signed integers will be interpreted as unsigned values.

NOTE:
A value of zero will be ignored and the default value of 20 will be used if zero is loaded and enabled.

Averaging Reset:

Y 27 is used to reset all 16 channels to begin the averaging process again. The previously loaded averaging sample number will be used or the default value of 20 if no data is loaded and the averaging function is enabled.

Averaging Reset with New Value:

In the event a very large number for averaging is inadvertently loaded into the module and enabled, the input channel will appear to not be working correctly. The input channel requires a reset with a smaller number of samples. To initiate a reset with a new averaging value, the number of samples is loaded as previously described and then each channel may be individually reset and enabled for the new value with WY 75.

4.2.7 Peak and Valley Hold

Peak or valley hold data is returned in locations WX 49 - WX 64 provided that Y 30 and Y 31 are set accordingly.

Data Read	Y 30	Y 31
Peak	1	1
Valley	0	1
Flags	X	0

Figure 24 *Peak/Valley Truth Table*

NOTE:

Upon power up and the enabling of peak and valley hold, peak values returned will be the actual value at input. Valley values must go below zero which is the default value before data is returned. This is not the case if a reset is issued to the valley function. On reset the valley threshold is the current value.

4.2.8 Peak and Valley Hold Reset

Outputs Y 28 and Y 29 are used to reset the valley or peak hold functions. The operation during reset is dependent on whether the hold function is enabled for each individual channel.

During reset of the peak value or the valley value the following occurs:

4.2.9 Flag Bits

Peak or Valley Hold Function	
Enabled	Reset to current input value
Disabled	Reset to zero

Figure 25 Peak/Valley Reset Truth Table

When not using peak or valley hold WX 49 - WX 54 returns flag bits for each of the functions and each of the channels may be interrogated with ladder logic instructions.

The flag bits correspond to the 16 channels in the module. The LSB or bit 16 corresponds to channel 1 and the MSB or bit 1 corresponds to channel 16.

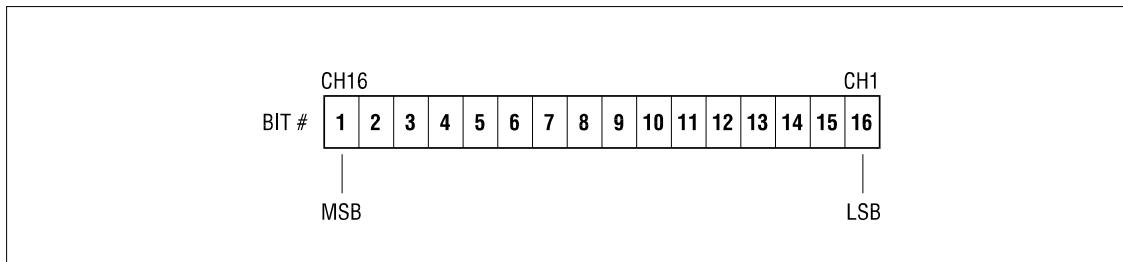

Figure 26 Mapping Bit Position to Channel Number

Alarm flags (WX 49):

The alarm flag bit is the logical OR of the low alarm bit (WX 5) and the high alarm bit (WX 50) for each channel. This allows one simple check to determine if an alarm exists on a channel. These alarm bits reset automatically when the alarm condition is no longer true. In the event that an alarm exists on a channel the ladder logic then may determine whether the alarm has reached the low alarm or the high alarm.

Overrange/Underrange flags:

The overrange (WX 52) and underrange (WX 53) flag bits are set any time that the analog to digital converter saturates and cannot produce any higher value for positive inputs or lower value for a negative input.

NOTE:

A zero input value is a reasonable input level of signal. It is not uncommon for the input to go below zero and the sign bit to change. The ADC will function below a value of Zero until saturation.

4.2.10 Advanced Function Precedence

When using more than one of the advanced functions it is necessary to understand the order in which these functions are performed in the 2556/2557 hardware. The order of precedence for these functions is as follows:

1. Scaling for low and high engineering units
2. Filtering
3. Alarm processing
4. Peak and Valley hold measurements
5. Averaging

CHAPTER 5. Troubleshooting

5.1 Troubleshooting the System

First examine your V or K memory tables to ensure that the data to be loaded into the module makes sense.

Utilize the worksheets in Appendix B and C to calculate key address locations.

Examine the relay ladder program to verify that the V memory tables are being loaded into the correct WY 65 - WY 96 output registers.

Examine the starting address of the module and ensure that the offsets for the X 16 input Module_Ready = (starting address + 15) and that the Y outputs = (starting address + 16), that the WX registers = (starting address + 32) and the WY registers = (starting address + 64).

Examine the relay ladder logic to verify that the addresses used match the offsets as described above and as those from the worksheets.

Verify that the data identification outputs Y 19 - Y 17 properly reference the data that is being loaded.

Use the TISOFT status and chart functions to debug the program and to verify that the X 16 Module_Ready input does indeed turn on. If this input does not turn on there is a problem with the module. See the section on RMA return policy.

Verify that the Y 32 Data_Ready output does indeed turn on to load the data into the 2556/2557 module.

Place a known input value on the module channel and verify that the channel is producing the correct results.

Symptom	Probable Cause	Corrective Action
wrong values	not logged in	login to PLC
no functions working	not logged in correctly	verify login
	ladder program did not execute	debug ladder program verify V memory tables
	offsets incorrect	calculate offsets starting address
	functions never enabled	ladder program must enable function after loading data

Figure 27 *Troubleshooting Flow Diagram*

APPENDIX A. I/O Register Quick Reference

X1	reserved	
thru		
X15		
X16	Module Ready (2556/2557 to PLC)	
Y17		
	0 1 0 1 0	
Y18	0 0 1 1 0	
Y19	0 0 0 0 1	
	filtering time constants/number of averages low /high scaling values low /high alarm values function enable no operation	
Y20		
thru	not used	
Y26		
Y27	Averaging reset (all channels)	
Y28	Valley hold reset (all channels)	
Y29	Peak hold reset (all channels)	
Y30	0 = read valley hold values; 1 = read peak hold values	
Y31	0 = read flags; 1 = read peak/valley hold values	
Y32	Data ready (PLC to 2556/2557)	
WX32		
	Channel 1 conversion data (in engineering units)	
thru		
WX48	Channel 16	
WX49	Alarm flag bits	
WX50	High alarm flags	
WX51	Low alarm flags	
WX52	Overrange flags	←-OR-→
WX53	Underrange flags	(ref Y31)
WX54	Overflow flags	
WX55	Open thermocouple/RTD flag	
WX56		
thru	reserved	
WX64		
		WX49 Channel 1 peak/valley hold thru WX64 Channel 16
WY65		
	Channel 1 low alarm setpoint (in engineering units)	if
thru		Y17=0
WY80	Channel 16	Y18=1
WY81	Channel 1 high alarm setpoint (in engineering units)	Y19=0
thru		
WY96	Channel 16	
WY65		
	Channel 1 scaling low setpoint (in engineering units)	if
thru		Y17=1
WY80	Channel 16	Y18=1
WY81	Channel 1 scaling high setpoint (in engineering units)	Y19=0
thru		
WY96	Channel 16	
WY65		
	Channel 1 filtering time constant (in milliseconds)	if
thru		Y17=0
WY80	Channel 16	Y18=0
WY81	Channel 1 averaging (number of samples)	Y19=1
thru		
WY96	Channel 16	
WY65		
	Low alarm enable (LSB = Ch 1, MSB = Ch 16)	
WY66	High alarm enable	if
WY67	Scaling enable	Y17=1
WY68	Digital filtering enable	Y18=0
WY69	Averaging enable	Y19=0
WY70	Peak hold enable	
WY71	Valley hold enable	
WY72	Degrees F or C select 1 = F	
WY73	Peak hold reset	
WY74	Valley hold reset	
WY75	Averaging reset with new sample counts	
WY76		
thru	reserved	
WY96		

APPENDIX B. V or K Memory Configuration Tables

Alarm Setpoints

Table address _____	
Channel #	Setpoint
1 _____	Low _____
	High _____
2 _____	Low _____
	High _____
3 _____	Low _____
	High _____
4 _____	Low _____
	High _____
5 _____	Low _____
	High _____
6 _____	Low _____
	High _____
7 _____	Low _____
	High _____
8 _____	Low _____
	High _____
9 _____	Low _____
	High _____
10 _____	Low _____
	High _____
11 _____	Low _____
	High _____
12 _____	Low _____
	High _____
13 _____	Low _____
	High _____
14 _____	Low _____
	High _____
15 _____	Low _____
	High _____

Scaling Units

Table address _____	
Channel #	Units
1 _____	Low _____
	High _____
2 _____	Low _____
	High _____
3 _____	Low _____
	High _____
4 _____	Low _____
	High _____
5 _____	Low _____
	High _____
6 _____	Low _____
	High _____
7 _____	Low _____
	High _____
8 _____	Low _____
	High _____
9 _____	Low _____
	High _____
10 _____	Low _____
	High _____
11 _____	Low _____
	High _____
12 _____	Low _____
	High _____
13 _____	Low _____
	High _____
14 _____	Low _____
	High _____
15 _____	Low _____
	High _____

Number of Averages

Table address _____	
Channel #	Number of Averages
1	_____
2	_____
3	_____
4	_____
5	_____
6	_____
7	_____
8	_____
9	_____
10	_____
11	_____
12	_____
13	_____
14	_____
15	_____
16	_____

Filtering Settling Time

Table address _____	
Channel #	Settling Time (milliseconds)
1	_____
2	_____
3	_____
4	_____
5	_____
6	_____
7	_____
8	_____
9	_____
10	_____
11	_____
12	_____
13	_____
14	_____
15	_____
16	_____

Function Enable Bits

Start of Enable block WY _____	
	Value
Low alarm	_____
High alarm	_____
Scaling	_____
Digital Filtering	_____
Averaging	_____
Peak Hold	_____
Valley Hold	_____
Fahrenheit/Centigrade	_____

APPENDIX C. Addressing Worksheet

PLC start login address (Start)	X _____
Module_Ready (Start +15)	X _____
Data Identification Bits (Y 17- Y 19)(Start +16)	Y _____
Data_Ready (Start +31)	Y _____
Averaging Reset (Start +26)	Y _____
Peak Hold Reset (Start + 27)	Y _____
Valley Hold Reset (Start +28)	Y _____
Start of WX registers (Start +32)	WX _____
Start of WY registers (Start +64)	WY _____
Peak/Valley Select Bit (Start +29)	Y _____
Flag Bits or Peak/Valley Select (Start +30)	Y _____

APPENDIX D. Items Unique to the Model 2556

Items unique to the Model 2556 Thermocouple Input Module.

Open Thermocouple Status Bits: WX55

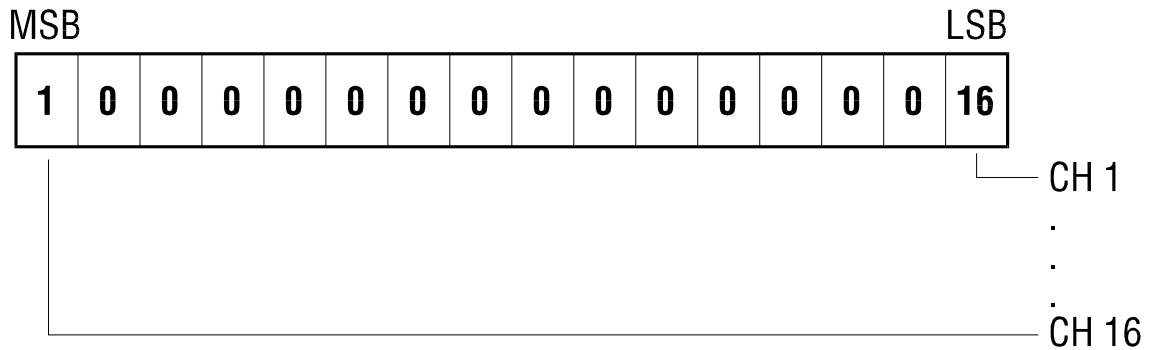

Figure 32 *Open Thermocouple Bits*

The bits returned in WX 55 indicate if there is an open thermocouple.

Front Panel Temperature: WX56

The measured temperature value of the front connector is reported in WX 56. The value is returned in tenths of degrees C.

EXAMPLE:

The front panel temperature is 25°C. The value returned in WX 56 is 250. (Temperature X10).

APPENDIX E. Items Unique to the Model 2557

Items unique to the Model 2557 RTD Input Module.

Open RTD Status Bits: WX55

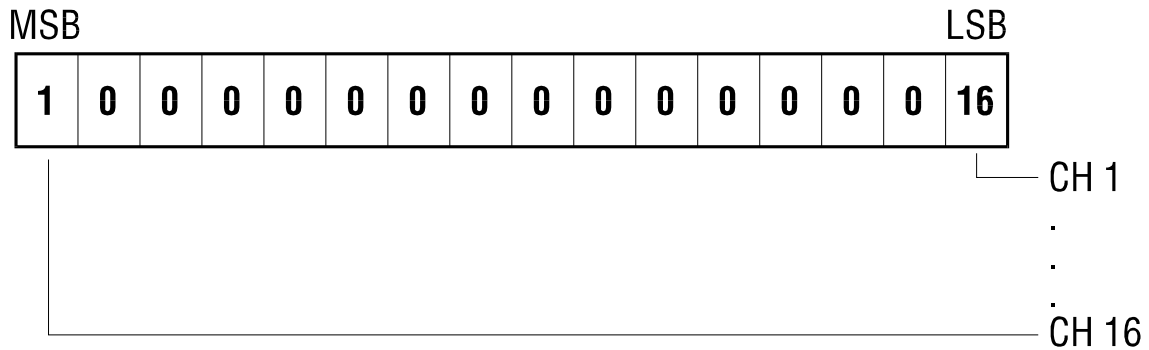

Figure 33 *Open RTD Status Bits*

The bits returned in WX 55 indicate an open RTD for a particular channel.

Floating Inputs:

If no RTD is connected to an input channel the value returned to the PLC is unpredictable.

The inputs on the Model 2557 are floating; that is there are no internal pull up or pull down circuits to force the input to either a maximum or minimum temperature value. Unused inputs therefore should be terminated by shorting the V+ and G terminals together.

USER NOTES

LIMITED PRODUCT WARRANTY

CTI warrants that this CTI Industrial Product shall be free from defects in material and workmanship for a period of one (1) year after purchase from CTI or from an authorized CTI Industrial Distributor. This CTI Industrial Product will be newly manufactured from new and/or serviceable used parts which are equal to new in the Product.

Should this CTI Industrial Product fail to be free from defects in material and workmanship at any time during this one (1) year warranty period, CTI will repair or replace (at its option) parts or Products found to be defective and shipped prepaid by the customer to a designated CTI service location along with proof of purchase date and associated serial number. Repair parts and replacement Product furnished under this warranty will be on an exchange basis and will be either reconditioned or new. All exchanged parts or Products become the property of CTI. Should any Product or part returned to CTI hereunder be found by CTI to be without defect, CTI will return such Product or part to the customer.

This warranty does not include repair of damage to a part or the Product resulting from: failure to provide a suitable environment as specified in applicable Product specifications, or damage caused by an accident, disaster, acts of God, neglect, abuse, misuse, transportation, alterations, attachments, accessories, supplies, non-CTI parts, non-CTI repairs or activities, or to any damage whose proximate cause was utilities or utility like services, or faulty installation or maintenance done by someone other than CTI.

Control Technology Inc. reserves the right to make changes to the Product in order to improve reliability, function, or design in the pursuit of providing the best possible Product. CTI assumes no responsibility for indirect or consequential damages resulting from the use or application of this equipment.

THE WARRANTY SET FORTH ABOVE IN THIS ARTICLE IS THE ONLY WARRANTY CTI GRANTS AND IT IS IN LIEU OF ANY OTHER IMPLIED OR EXPRESSED GUARANTY OR WARRANTY ON CTI PRODUCTS, INCLUDING WITHOUT LIMITATION, ANY WARRANTY OF MERCHANTABILITY OR OF FITNESS FOR A PARTICULAR PURPOSE AND IS IN LIEU OF ALL OBLIGATIONS OR LIABILITY OF CTI FOR DAMAGES IN CONNECTION WITH LOSS, DELIVERY, USE OR PERFORMANCE OF CTI PRODUCTS OR INTERRUPTION OF BUSINESS, LOSS OF USE, REVENUE OR PROFIT. IN NO EVENT WILL CTI BE LIABLE FOR SPECIAL, INCIDENTAL, OR CONSEQUENTIAL DAMAGES.

SOME STATES DO NOT ALLOW THE EXCLUSION OR LIMITATION OF INCIDENTAL OR CONSEQUENTIAL DAMAGES FOR CONSUMER PRODUCTS, SO THE ABOVE LIMITATIONS OR EXCLUSIONS MAY NOT APPLY TO YOU.

THIS WARRANTY GIVES YOU SPECIFIC LEGAL RIGHTS, AND YOU MAY ALSO HAVE OTHER RIGHTS WHICH MAY VARY FROM STATE TO STATE.

REPAIR POLICY

In the event that the Product should fail during or after the warranty period, a Return Material Authorization (RMA) number can be requested verbally or in writing from CTI main offices. Whether this equipment is in or out of warranty, a Purchase Order number provided to CTI when requesting the RMA number will aid in expediting the repair process. The RMA number that is issued and your Purchase Order number should be referenced on the returning equipment's shipping documentation. Additionally, if under warranty, proof of purchase date and serial number must accompany the returned equipment. The current repair and/or exchange rates can be obtained by contacting CTI's main office at +1-800-537-8398.

When returning any module to CTI, follow proper static control precautions. Keep the module away from polyethylene products, polystyrene products and all other static producing materials. Packing the module in its original conductive bag is the preferred way to control static problems during shipment. **Failure to observe static control precautions may void the warranty.** For additional information on static control precautions, contact CTI's main office at +1-800-537-8398.