

**CTI 2555-A SIXTEEN CHANNEL
DIFFERENTIAL ANALOG INPUT MODULE
INSTALLATION AND OPERATION GUIDE**

Version 1.3

**Copyright © 2022 Control Technology Inc.
All rights reserved.**

This manual is published by Control Technology Inc., 5734 Middlebrook Pike, Knoxville, TN 37921. This manual contains references to brand and product names which are tradenames, trademarks, and/or registered trademarks of Control Technology Inc. 2500 Series® and Siemens SIMATIC® are registered trademarks of Siemens AG. Other references to brand and product names are tradenames, trademarks, and/or registered trademarks of their respective holders.

DOCUMENT DISCLAIMER STATEMENT

Every effort has been made to ensure the accuracy of this document; however, errors do occasionally occur. CTI provides this document on an "as is" basis and assumes no responsibility for direct or consequential damages resulting from the use of this document. This document is provided without express or implied warranty of any kind, including but not limited to the warranties of merchantability or fitness for a particular purpose. This document and the products it references are subject to change without notice. If you have a comment or discover an error, please call us toll-free at 1-800-537-8398.

REVISION HISTORY

Version 1.0	3/17/98	Updated product name revision from 2555 to 2555-A.pdb
Version 1.1	3/27/2020	Converted old file to new .docx file. Added new product pics.pdb
Version 1.2	8/24/2020	Added references to CTI 2500 Series in document and noted the connector and part number is sold separately. pdb
Version 1.3	5/2/2022	Added Reference to Low/Density Section 2.3.6 and updated Figure 14. Also added reference to CTI 2500 Series®.pdb

PREFACE

This *Installation and Operation Guide* provides installation and operation instructions for the CTI 2555-A Sixteen Channel Differential Analog Input Module for CTI 2500 Series® Classic Systems and the SIMATIC® Series 505 programmable controllers. We assume you are familiar with the operation of CTI 2500 Series® Classic Systems programmable controllers. Refer to the appropriate CTI 2500 Series® Classic Systems user documentation for specific information on the CTI 2500 Series® Classic Systems programmable controllers and I/O modules.

This *Installation and Operation Guide* is organized as follows:

Chapter 1 provides a description of the module.

Chapter 2 covers installation and wiring.

Chapter 3 is a guide to troubleshooting.



Figure 1 The Model 2555-A 16-Channel Differential Analog Input Module

USAGE CONVENTIONS

NOTE:

Notes alert the user to special features or procedures.

CAUTION:

Cautions alert the user to procedures which could damage equipment.

WARNING:

Warnings alert the user to procedures which could damage equipment and endanger the user.

STATEMENT OF PRODUCT COMPATIBILITY:

The 255X 16-point I/O module is compatible with all of the SIMATIC® PLCs including 535, 545 and 555 except for the Model 525. The Model 525 will not support the high density WX 16 mode that is required for operation.

Table of Contents

CHAPTER 1. DESCRIPTION	1
1.1 Front Panel Description	1
1.1.1 Active LED.....	1
1.1.2 Input Connector for Channels 1-16	2
1.2 Asynchronous Operation	2
1.3 Immediate I/O.....	2
1.4 Unipolar or Bipolar Mode	2
1.5 Voltage or Current Mode.....	2
1.6 Digital Word Map	2
1.6.1 Unipolar Presentation	3
1.6.2 Bipolar Presentation	3
1.7 Analog to Digital Conversion.....	4
1.7.1 Unipolar Mode Conversion	4
1.7.2 Bipolar Mode Conversion.....	4
1.7.3 Example Conversion.....	5
1.8 Effect of Out-of-Range Input Signals	6
1.8.1 Unipolar Mode	6
1.8.2 Bipolar Mode.....	6
1.9 Using the Module with 20% Offset	8
1.10 Resolution.....	8
CHAPTER 2. INSTALLATION	10
2.1 Planning the Installation	10
2.1.1 Calculating the I/O Base Power Budget	10
2.1.2 Input Signal Wiring	10
2.2 Unpacking the Module	11
2.3 Configuring the Module	11
2.3.1 Selecting Voltage or Current Input Mode (JP1, JP2, JP3, JP4).....	12
2.3.2 Selecting Voltage Range JP5-JP20.....	14
2.3.3 Selecting Unipolar or Bipolar Input Mode	14
2.3.4 Selecting Digital Filtering.....	14
2.3.5 Selecting Advanced Programming Features Mode	14
2.3.6 Logging the Configuration Jumper Settings	14
2.4 Inserting the Module Into the I/O Base	15
2.5 Wiring the Input Connectors	15
2.5.1 Connecting Voltage Input Wiring.....	15
2.5.2 Connecting Current Input Wiring.....	16
2.6 Inserting the Screw Terminal Connector.....	17
2.7 Checking Module Operation	18
CHAPTER 3. TROUBLESHOOTING.....	19
SPECIFICATIONS.....	20
JUMPER SETTINGS LOG SHEET	21

TABLE OF FIGURES

Figure 1 The Model 2555-A 16-Channel Differential Analog Input Module	3
Figure 2 Front Panel Description	1
Figure 3 Word Input to the PLC from the Module (Unipolar)	3
Figure 4 Word Input to the PLC from the Module (Bipolar).....	3
Figure 5 Example of Change in Input Level.....	5
Figure 6 Voltage Input Limits (Unipolar)	6
Figure 7 Voltage Input Limits (Bipolar)	6
Figure 8 Typical Unipolar Overrange Word Value	7
Figure 9 Typical Unipolar Underrange Word Value	7
Figure 10 Typical Bipolar Overrange Word Value	7
Figure 11 Typical Bipolar Underrange Word Value	8
Figure 12 Input Resolution.....	9
Figure 13 Factory Configuration Jumper Settings.....	11
Figure 14 Configuration Jumper Locations.....	13
Figure 15 Screw Terminal Plug Wiring	15
Figure 16 Typical Internal Circuit - Voltage Mode.....	16
Figure 17 Typical Internal Circuit - Current Mode	16
Figure 18 Input Connector Assembly	17
Figure 19 Example I/O Configuration Chart.....	18
Figure 20 Troubleshooting Matrix	19
Figure 21 Jumper Settings Log	21

CHAPTER 1. DESCRIPTION

The Sixteen Channel Analog Input Module is a member of the Control Technology Inc. (CTI) family of Input/Output (I/O) modules for CTI 2500 Series® Classic Systems programmable controllers. The Model 2555-A is designed to translate an analog input signal into an equivalent digital word which is then sent to the programmable controller (PLC).

STATEMENT OF PRODUCT COMPATIBILITY:

All 16-point I/O modules including the 2555-A, 2556-A and 2557-A are compatible with all of the CTI 2500 Series® CPUs and SIMATIC® TI PLCs including 535, 545 and 555 except for the Model 525. The Model 525 will not support the high density WX 16 mode that is required for operation.

1.1 Front Panel Description

1.1.1 Active LED

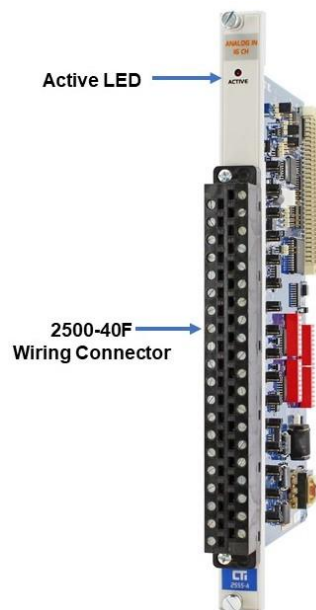

Figure 2 Front Panel Description

The active LED will be illuminated when the module is functioning normally. If the Active LED is not lit, refer to Chapter 3 for troubleshooting.

1.1.2 Input Connector for Channels 1-16

This connector provides wiring terminals for channels 1-16. Note: The connector is sold separately. The part number is 2500-40F

1.2 Asynchronous Operation

The module operates asynchronously with respect to the PLC (a scan of the PLC and input sampling of the module do not occur at the same time). Instead, the module will translate all analog inputs in one module update (approximately 6 milliseconds) and store the translated words in buffer memory. The PLC retrieves the stored words from the module buffer memory at the start of the I/O scan.

1.3 Immediate I/O

The Model 2555-A Differential Analog Input Module is fully compatible with the Immediate Input function in the SIMATIC® 545 and 555 PLC.

1.4 Unipolar or Bipolar Mode

The module may be configured to accept either bipolar or unipolar input signals. Selection of unipolar or bipolar mode is made via one internal jumper per channel (see Section 2.3.3).

1.5 Voltage or Current Mode

Each of the module's sixteen channels may be configured to receive either voltage or current analog input signals. For unipolar input signals, the range is 0 to 5 VDC, 0 to 10 VDC or 0 to +20 mA. For bipolar input signals, the signal range is -5 to +5 VDC, -10 to +10 VDC or -20 to +20 mA. Selection of voltage or current mode and voltage range are made via internal jumpers (see Sections 2.3.1 and 2.3.2).

1.6 Digital Word Map

A unipolar analog input signal is translated into a 14-bit digital word. A bipolar input signal is translated into a 13-bit digital word plus 1-bit for the polarity sign. Since the PLC requires a 16-bit input word, the 14-bit value from the converter is placed into a 16-bit word for transmittal to the PLC.

1.6.1 Unipolar Presentation

As shown in the following figure, of the two bits not used for the digital word, one is used to show the sign of the word, one is used to note values which are “overrange/underrange”.

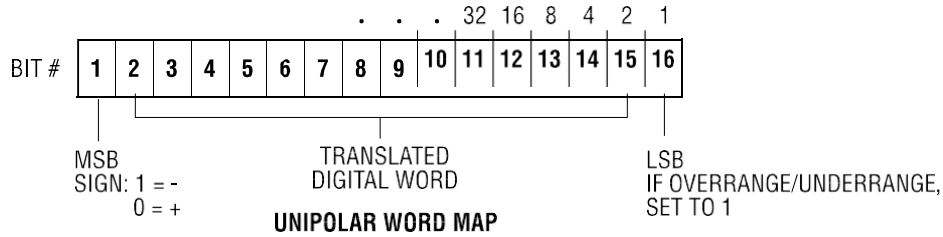

Figure 3 Word Input to the PLC from the Module (Unipolar)

1.6.2 Bipolar Presentation

As shown in the following figure, of the three bits not used for the digital word, one is used to show the sign of the word, one is used to note values which are “overrange”, and the remaining bit is not used and set to zero.

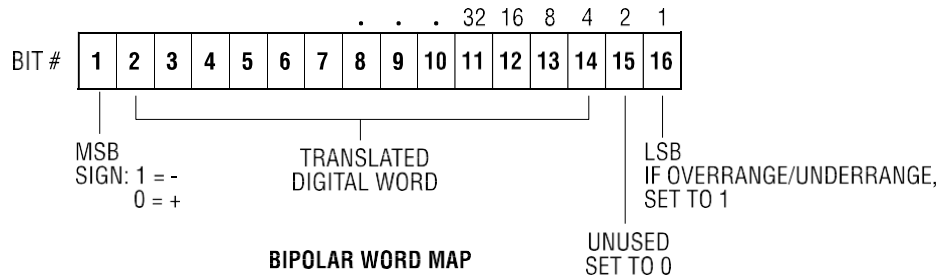

Figure 4 Word Input to the PLC from the Module (Bipolar)

NOTE:

In the Bipolar Word Map bit 15 is unused. There will however be cases where bit 15 will not be zero as indicated. Bipolar Mode consists of 13 bits plus a sign bit. When this data is transformed to a 16 bit word space to the PLC some codes will result that will include bit 15.

1.7 Analog to Digital Conversion

1.7.1 Unipolar Mode Conversion

The following equations may be used to calculate the digital word which will result from a particular voltage or current input in the Unipolar Input Mode:

$$\text{0 to 5 V Input Range Mode, Digital Word (WX)} = \frac{+\text{Input voltage (V)} \times 32000}{5 \text{ volts}}$$

$$\text{0 to 10 V Input Range Mode, Digital Word (WX)} = \frac{+\text{Input voltage (V)} \times 32000}{10 \text{ volts}}$$

$$\text{0 to 20 mA Input Range Mode, Digital Word (WX)} = \frac{+\text{Input current (mA)} \times 32000}{20 \text{ mA}}$$

1.7.2 Bipolar Mode Conversion

The following equations may be used to calculate the digital word which will result from a particular voltage or current input in the Bipolar Input Mode:

$$\text{-5 to +5 V Input Range Mode, Digital Word (WX)} = \frac{\pm\text{Input voltage (V)} \times 32000}{5 \text{ volts}}$$

$$\text{-10 to +10 V Input Range Mode, Digital Word (WX)} = \frac{\pm\text{Input voltage (V)} \times 32000}{10 \text{ volts}}$$

$$\text{-20 to +20 mA Input Range Mode, Digital Word (WX)} = \frac{\pm\text{Input current (mA)} \times 32000}{20 \text{ mA}}$$

1.7.3 Example Conversion

As an example, the following figure illustrates the effects of a change in input level going from .3125 to .625 mV in the 0 to 5V Unipolar Input Mode. (For the 0 to 10V and 0 to 20mA Unipolar Input Modes, or the Bipolar Modes, refer to the formulas given in Sections 1.7.1 and 1.7.2 to determine the digital word which results from a particular input.)

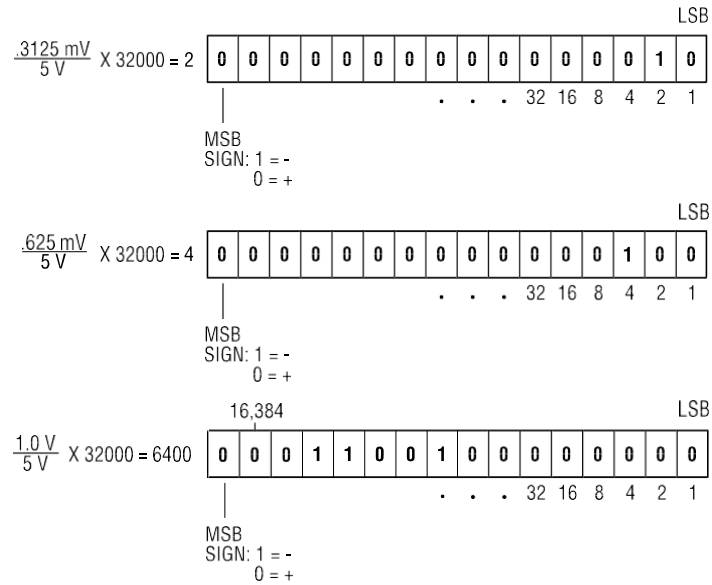

Figure 5 Example of Change in Input Level

1.8 Effect of Out-of-Range Input Signals

The Model 2555 utilizes the overrange and underrange bit to indicate when a channel has reached individual limits. The value of the overrange or underrange condition varies from channel to channel. The reason for this is that as a channel is calibrated all of the gains and offsets and dynamic ranges of the analog to digital converter of the system are compensated for in each analog input channel. Therefore the point at which the analog to digital converter reaches a saturation point and can no longer produce a change in counts for a corresponding change in input signal is called the overrange or underrange limit of the channel. This level is different for every channel. In the figures below the limits for the overrange and underrange values are the minimum limits for a given channel. The actual limits for an individual channel may be greater.

1.8.1 Unipolar Mode

Signals falling above or below the upper and lower limits in 0 to 5V Input Mode or 0 to 10V Input Mode are translated into a digital word that includes the addition of bit 16 to indicate an overrange or underrange condition. Note that although the digital word may approach zero as the analog input signal approaches the minimum for a given range, the digital word will never actually be zero. In fact the underrange capability of any channel in Unipolar Mode may produce a negative value to the PLC for a number of counts before the underrange bit is set.

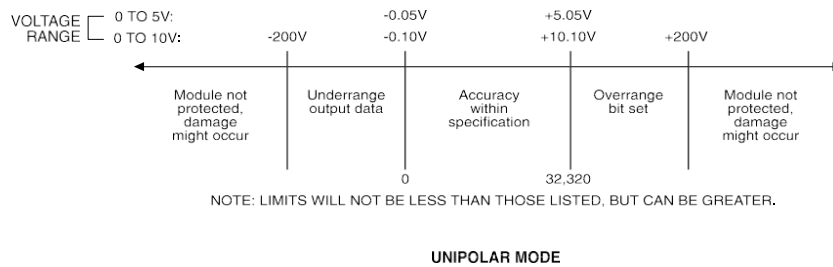

Figure 6 Voltage Input Limits (Unipolar)

1.8.2 Bipolar Mode

In Bipolar Mode signals above or below the upper and lower limits in the -5 to +5VDC or -10 to +10VDC range are translated to a digital word and also utilize the overrange or underrange bit. The actual limit for each channel will vary from channel to channel as described above.

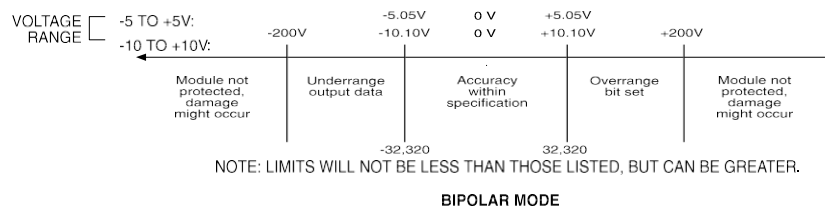

Figure 7 Voltage Input Limits (Bipolar)

Figures 8 and 9 show the binary values of typical overrange and underrange conditions for Unipolar mode.

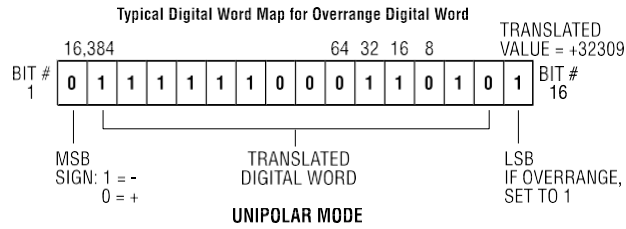

Figure 8 Typical Unipolar Overage Word Value

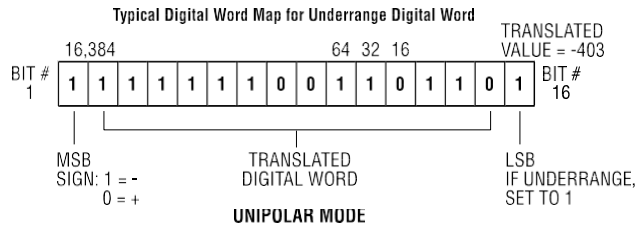

Figure 9 Typical Unipolar Underrange Word Value

Figures 10 and 11 show the binary values of typical overrange and underrange conditions for Bipolar mode.

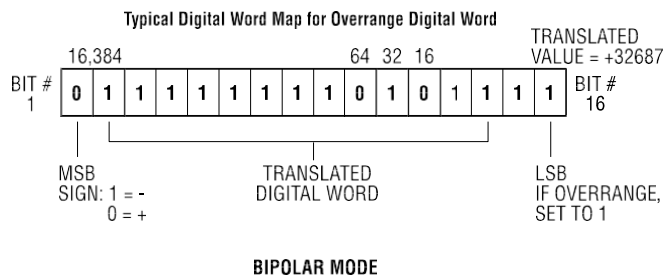

Figure 10 Typical Bipolar Overage Word Value

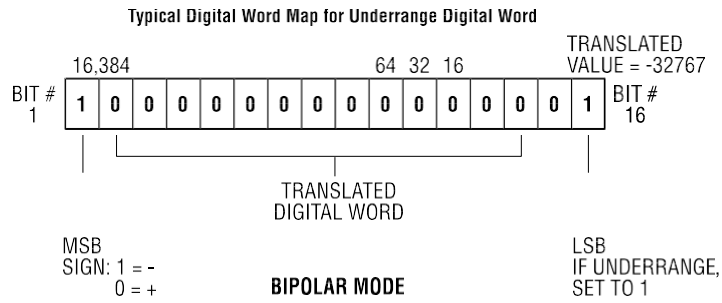

Figure 11 Typical Bipolar Underrange Word Value

1.9 Using the Module with 20% Offset

Most applications use transducers that provide 1 to 5 volt or 4 to 20 mA input signals instead of 0 to 5 volt or 0 to 20 mA input signals. You can allow for this 20% offset by including some additional instructions in your RLL (Relay Ladder Logic) program.

First, subtract 6400 from the input data word (WX). Then, multiply the result by 125 and divide the product by 100. This yields the following equation:

$$\frac{(WX-6400) \times 125}{100} = 20\% \text{ offset data word}$$

Consult your PLC programming manual (or program design guide) for information about the RLL instructions used in the conversion.

1.10 Resolution

In the Unipolar Input Mode, the module has a resolution of 2 counts out of 32000. That is the smallest unit into which the module will divide an input is 1 part out of 16000. This relationship can be shown as:

$$\frac{2 \text{ counts per step}}{32000 \text{ counts full scale}} = \frac{1}{16000}$$

In Bipolar Mode, the resolution is 4 counts out of 32000, so that the smallest unit into which the module will divide an input is 1 part out of 8000. This relationship can be shown as:

$$\frac{4 \text{ counts per step}}{32000 \text{ counts full scale}} = \frac{1}{8000}$$

When using the module with 20% offset, module resolution remains at 2 counts out of 32000, but offset resolution becomes 4 counts out of 32000 as a result of the multiplication and division of the incoming data word.

The chart below shows the corresponding input resolution per step for each of the input configuration modes:

	RANGE CONFIGURATION	DIGITAL COUNTS / STEP	INPUT RESOLUTION PER STEP
UNIPOLAR	0 - 5 VDC	2	0.3125 mV
	0 - 10 VDC	2	0.625 mV
	0 - 20 mA	2	1.25 μ A
UNIPOLAR WITH 20% OFFSET	1 - 5 VDC	4	0.625 mV
	4 - 20 mA	4	2.50 μ A
BIPOLAR	-5 TO +5 VDC	4	0.625 mV
	-10 TO +10 VDC	4	1.25 mV
	0 - 20 mA	4	2.50 μ A

Figure 12 Input Resolution

CHAPTER 2. INSTALLATION

The installation of the Sixteen Channel Analog Input Module involves the following steps:

1. Planning the installation
2. Configuring the module
3. Inserting the module into the I/O base
4. Wiring and connecting the module input connectors
5. Checking module operation

The steps listed above are explained in detail in the following pages.

2.1 Planning the Installation

Planning is the first step in the installation of the module. This involves calculating the I/O base power budget and routing the input signal wiring to minimize noise. The following sections discuss these important considerations.

2.1.1 Calculating the I/O Base Power Budget

The Model 2555-A requires 5.0 watts of +5 VDC power from the I/O base. Use this value to verify that the base power supply capacity is not exceeded.

2.1.2 Input Signal Wiring

Input signal wiring must be shielded twisted-pair cable. The shielding for the cable should always be terminated at the Model 2555-A. Each group of four input channels contain two termination points for the shield wire.

The shield wire should be terminated at the designated shield terminals only to minimize the effects of noise on the measuring system.

Note the following general considerations when wiring the module:

- Always use the shortest possible cables
- Avoid placing low voltage wire parallel to high energy wire (if the two wires must meet, cross them at a right angle)
- Avoid bending the wire into sharp angles Use wireways for wire routing
- Avoid placing wires on any vibrating surface

2.2 Unpacking the Module

Open the shipping carton and remove the special anti-static bag which contains the module.

CAUTION:
HANDLING STATIC SENSITIVE DEVICES

The components on the Model 2555-A module printed circuit card can be damaged by static electricity discharge. To prevent this damage, the module is shipped in a special anti-static bag. Static control precautions should be followed when removing the module from the bag, when opening the module, and when handling the printed circuit card during configuration.

After discharging any static build-up, remove the module from the static bag. **Do not discard the static bag. Always use this bag for protection against static damage when the module is not inserted into the I/O backplane.**

2.3 Configuring the Module

The Model 2555-A must be configured for voltage or current inputs, voltage range, unipolar/bipolar mode, and digital filtering/no filtering mode before wiring the input connector and inserting the module into the I/O base. **As shipped, all input channels are configured for current inputs, 5V range (see Note below), unipolar mode, and digital filtering enabled (see Figure 13).**

NOTE:

The 5V input signal range configuration is used for both 0 to 5 VDC and 1 to 5 VDC or 4 to 20 mA and 0 to 20 mA input signal ranges.

CHANNEL NUMBER	VOLTAGE JUMPER	JUMPER POSITION V or I	VOLTAGE RANGE JUMPER	JUMPER POSITION 5V or 10V	UNIPOLAR BIPOLAR JUMPER	JUMPER POSITION UNI or BIP
1	JP 1		JP 5	5V	JP 5	UNI
2		2	JP 6	5V	JP 6	UNI
3		3	JP 7	5V	JP 7	UNI
4		4	JP 8	5V	JP 8	UNI
5	JP 2	5	JP 9	5V	JP 9	UNI
6		6	JP 10	5V	JP 10	UNI
7		7	JP 11	5V	JP 11	UNI
8	JP 3	8	JP 12	5V	JP 12	UNI
9		9	JP 13	5V	JP 13	UNI
10		10	JP 14	5V	JP 14	UNI
11		11	JP 15	5V	JP 15	UNI
12	JP 4	12	JP 16	5V	JP 16	UNI
13		13	JP 17	5V	JP 17	UNI
14		14	JP 18	5V	JP 18	UNI
15		15	JP 19	5V	JP 19	UNI
16			JP 20	5V	JP 20	UNI

ALL CHANNELS	UNIPOLAR BIPOLAR SWITCHES	VOLTAGE RANGE SWITCHES	DIGITAL FILTERING JUMPER	JUMPER POSITION FIL/none
1-16	SW 7	SW 5	JP 121	FIL
	SW 8	SW 6		

Figure 13 Factory Configuration Jumper Settings

Changing the module input channel configuration involves the following steps:

1. Selecting voltage (V) or current (I) input mode for each channel
2. Selecting 0 to 5V or 0 to 10V voltage range for each channel
3. Selecting unipolar or bipolar input mode for each channel
4. Selecting digital filtering or no filtering for the module

Logging the configuration jumper settings for future reference Each of these steps is described in the following sections.

2.3.1 Selecting Voltage or Current Input Mode (JP1, JP2, JP3, JP4)

Locate the 16 Voltage/Current Jumpers corresponding to input channels 1 through 16. See Figure 14 for the location of these jumpers. For each input channel, select current mode by placing the jumper in the “Current” position or voltage mode by placing the jumper in the “Voltage” position. For each input channel set to current mode, you must set the corresponding Voltage Range Jumper to the 5V position as described in the following section. (The silkscreen on the printed circuit board is marked to indicate the voltage or current position for each channel.)

NOTE:

Each channel utilizes jumpers to configure the hardware and DIP switches to configure the microcomputer.

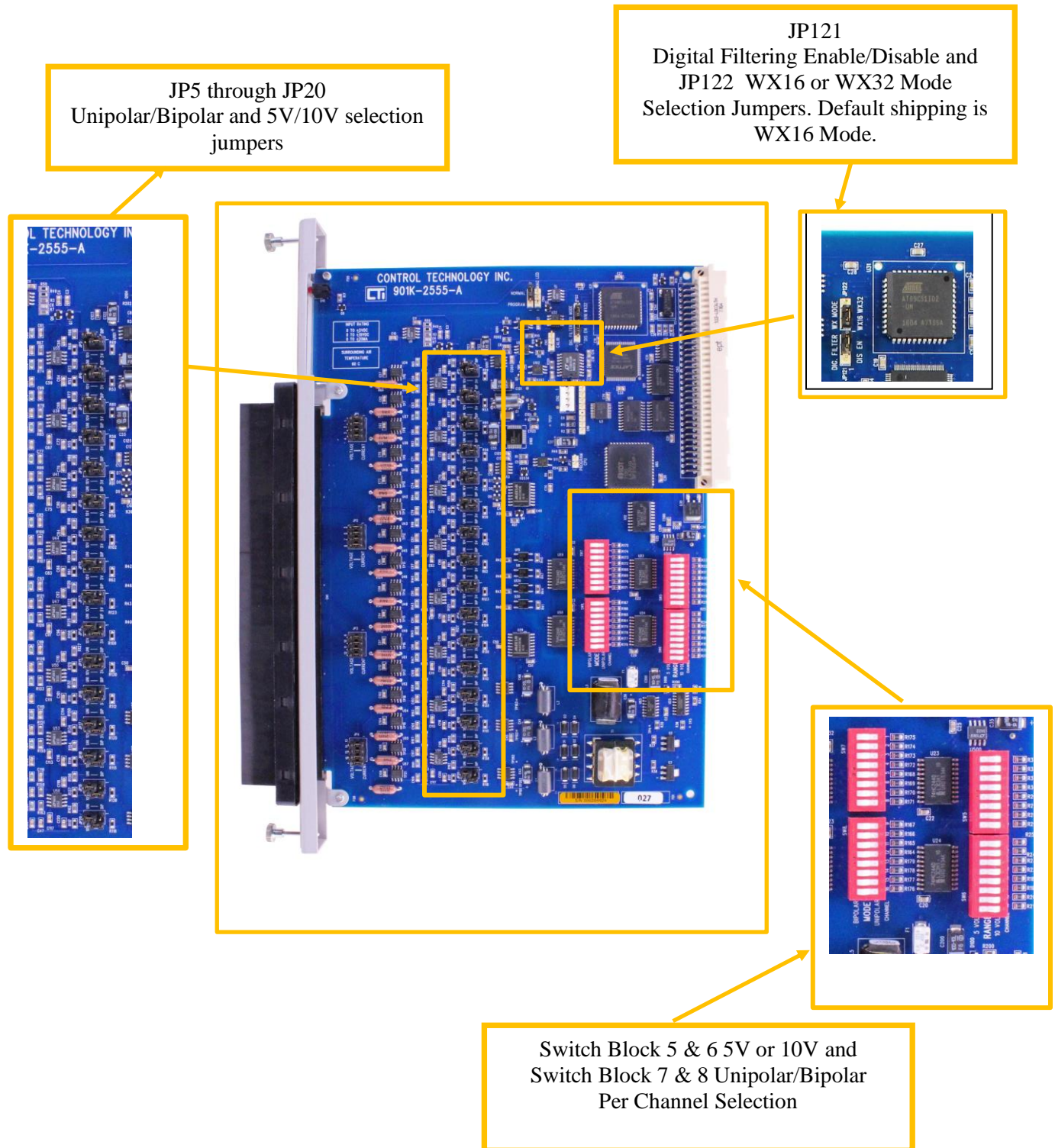

Figure 14 Configuration Jumper Locations

2.3.2 Selecting Voltage Range JP5-JP20

Locate the Voltage Range Jumpers corresponding to input channels 1 through 16 (see Figure 14). For each input channel operating in current mode, set the corresponding Voltage Range Jumper to 5V.

CAUTION:

For each input channel configured for current mode, the corresponding Voltage Range Jumper must be set to 5V or damage will result to the module.

For each input channel operating in voltage mode, set the corresponding Voltage Range Jumper to 5V for 0 to +5VDC input range or 10V for 0 to 10VDC or -10 to +10VDC input range. Locate DIP switches SW5 and SW6 and for each channel select the voltage range as previously selected with the jumpers.

2.3.3 Selecting Unipolar or Bipolar Input Mode

Locate the Unipolar/Bipolar Jumpers JP5 through JP20 (see Figure 14). For each channel select UNI or BIP for Unipolar or Bipolar mode. Next set DIP switches SW7 and SW8 for each channel to the same selection as the corresponding jumpers JP5-JP20.

2.3.4 Selecting Digital Filtering

Locate the Digital Filtering/No Filtering Jumper JP121 (see Figure 14). To enable digital filtering, set the jumper in the FIL position. Since many analog input signals contain noise, CTI recommends using digital filtering unless maximum response time is required.

Digital Filter Time Constant:

The time constant for the Model 2555-A is 25 milliseconds. An input signal from zero to full scale will require 4 to 5 time constants to reach a final value. Therefore the effect of digital filtering will slow the response of the module to 100 milliseconds.

2.3.5 Selecting Advanced Programming Features Mode

Jumper JP122 on the module selects the standard 16 WX login or the high-density advanced function interface. When the High Density mode is selected Scaling, alarming, peak/valley hold, digital filtering, and averaging are available on a per-channel basis and are selected through a simple PLC configuration routine. The module logs in as 16X / 16Y / 32WX / 32WY when these advanced functions are enabled. See the [“255x Advanced Function Programming Reference Manual”](#) for more information.

2.3.6 Logging the Configuration Jumper Settings

For future reference, it is advisable to log the configuration jumper settings. Record this configuration in the section labeled “Jumper Settings Log Sheet” after the Specifications page toward the end of this manual.

2.4 Inserting the Module Into the I/O Base

WARNING:

The module must not be inserted into the I/O rack while rack power is applied.

Insert the module into the I/O base by carefully pushing the module into the slot. When the module is fully seated in the slot and backplane connector, tighten the captive screws at the top and bottom to hold the module in place. To remove the module from the I/O base, loosen the captive screws, then remove the module from the I/O base. Be careful not to damage the DIN connector at the back of the module when inserting or removing the module.

2.5 Wiring the Input Connectors

Input signals are accepted through a connector assembly located on the front of the module. The connector assembly consists of a standard CTI 2500 Series® wiring connector (see Figure 18). Wiring is connected through the screw terminal plug. The screw terminals can accept wire sizes up to single stranded 14 gauge wire. The actual size wire used depends on the external device providing the input signal. Consult the device manufacturer's recommendations for selecting the input wire size.

To assign an input to a specific channel, locate the appropriate channel position on the screw terminal plug as shown in the following figure:

2.5.1 Connecting Voltage Input Wiring

For voltage input circuits, connect the signal wire to the + (positive) screw terminal, and the return wire to the - (negative) screw terminal. The ground terminals labeled SHIELD provide a convenient location to terminate the shield. Insert the wires in the appropriate holes on the front of the connector adjacent to the corresponding screw. When the wires are inserted, tighten the screws. Repeat this procedure for the remaining voltage input channels. The 2555-A inputs are full differential input amplifiers that may be driven in a differential or single ended mode.

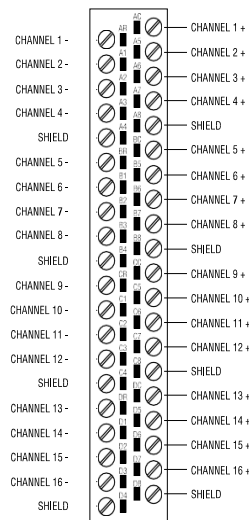

Figure 15 Screw Terminal Plug Wiring

For voltage input circuits, connect the signal wire to the + (positive) screw terminal, and the return wire to the - (negative) screw terminal. The ground terminals labeled SHIELD provide a convenient location to terminate the shield. Insert the wires in the appropriate holes on the front of the connector adjacent to the corresponding screw. When the wires are inserted, tighten the screws. Repeat this procedure for the remaining voltage input channels. The 2555-A inputs are full differential input amplifiers that may be driven in a differential or single ended mode.

2.5.2 Connecting Current Input Wiring

For current input circuits, connect the signal wire to the + (positive) screw terminal, and the return wire to the - (negative) screw terminal. The ground terminals labeled SHIELD provide a convenient location to terminate the shield. Insert the wires in the appropriate holes on the front of the connector adjacent to the corresponding screw. When the wires are inserted, tighten the screws. Repeat this procedure for the remaining current input channels.

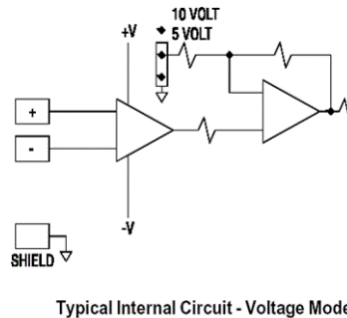

Figure 16 Typical Internal Circuit - Voltage Mode

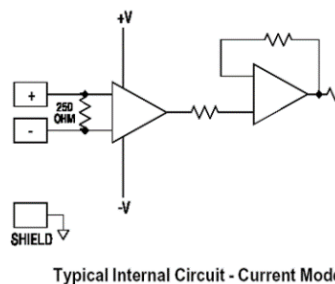

Figure 17 Typical Internal Circuit - Current Mode

NOTE:
No external current resistor is required in current mode.

2.6 Inserting the Screw Terminal Connector

When all the input signal wires are connected to the screw terminal align the edge of the printed circuit board with the corresponding edge of the wiring connector and press the connector on the circuit board until the connector is fully seated. Next align the captive screws on the top and bottom of the connector with the front panel and tighten until the module connector is fully seated.

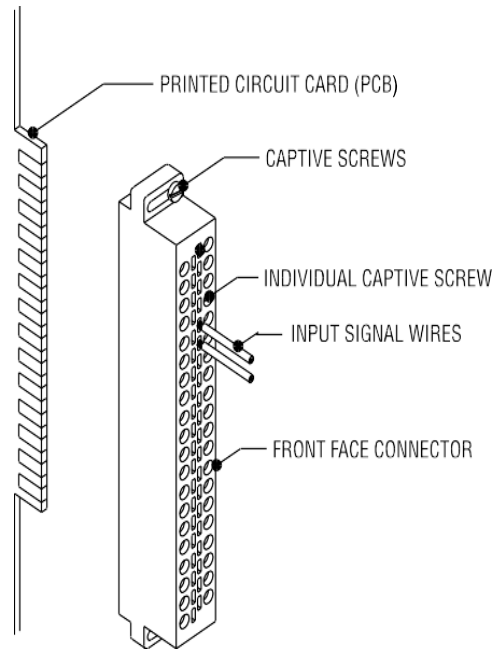

Figure 18 Input Connector Assembly

NOTE:

The connector is sold separately. The part number is 2500-40F

2.7 Checking Module Operation

First turn on the base power supply. If the module diagnostics detect no problems, the status indicator on the front of the module will light. If the status indicator does not light, blinks, (or goes out during operation), the module has detected a failure. For information on viewing failed module status, refer to your Fastrak Workshop user manual. To diagnose and correct a module failure, refer to the next section on troubleshooting.

You must also check that the module is configured in the memory of the PLC. This is important because the module will appear to be functioning regardless of whether it is communicating with the PLC. To view the PLC memory configuration chart listing all slots on the base and the inputs or outputs associated with each slot, refer to your SIMATIC® TISOFT Programming Manual. An example chart is shown in the following figure. The Model 2555-A logs in to the PLC as 16 WX inputs.

```

I/O MODULE DEFINITION FOR CHANNEL ... 1  BASE ..... 00

      I/O  NUMBER OF BIT AND WORD I/O SPECIAL
SLOT ADDRESS      X  Y  WX  WY  FUNCTION
01 .... 0001 ..... 00..00.. 16..00 ..... NO
02 .... 0000 ..... 00..00.. 00..00 ..... NO
      .
      .
15 .... 0000 ..... 00..00..00..00 ..... NO
16 .... 0000 ..... 00..00..00..00 ..... NO
  
```

Figure 19 Example I/O Configuration Chart

In this example, the Model 2555-A module is inserted in slot 1 in I/O base 0. Data for channel 1 appears in word location WX1, data for channel 2 appears in word location WX2, etc. For your particular module, look in the chart for the number corresponding to the slot occupied by the module. If word memory locations appear on this line, then the module is registered in the PLC memory and the module is ready for operation.

If the line is blank or erroneous, re-check the module to ensure that it is firmly seated in the slots. Generate the PLC memory configuration chart again. If the line is still incorrect, contact your local distributor or CTI at 1-800-537-8398 for further assistance.

CHAPTER 3. TROUBLESHOOTING

If the module provides improper readings or the status indicator is not on, use the following chart to determine the appropriate corrective action.

SYMPTOM	PROBABLE CAUSE	CORRECTIVE ACTION
Indicator is not lit	Base or PLC power is off	Turn base or PLC on
	Defective module	Return the module to CTI for repair
Blinking indicator	EEPROM failure	Return the module to CTI for repair
Incorrect inputs	Blown fuse	Return the module to CTI for repair
	Wrong addresses for word input	Check program for correct word input addresses
	Not logged-in	Read I/O configuration
	Incorrect jumper settings	Refer to proper section of this Installation & Operation guide for jumper settings
	Incorrectly calibrated	Return the module to CTI for recalibration
	Noisy signal	Check for proper shield termination at input connectors

Figure 20 Troubleshooting Matrix

When it is inconvenient to visually check the status indicator, use the TISOFT “Display Failed I/O” or “Show PLC Diagnostics” support functions. Note that if the module power supply fails, the module will still be logged into the PLC even though it is not operating. In this case, “Display Failed I/O” will not provide the information to accurately diagnose the problem.

CAUTION:

The module fuse (F1) is not user serviceable. If this fuse is blown, the module has a serious component failure and should be returned to CTI for repair.

If after consulting the chart above, you are unable to diagnose or solve the problem, contact your local distributor or CTI at 1-800-537-8398 for further assistance.

SPECIFICATIONS

Input Channels:	16 differential input channels (140 VRMS channel-to-channel common mode rejection CMR)
Signal Range:	Unipolar: 0 to 5 VDC, 0 to 10 VDC, or 0 to 20 mA Bipolar: -5 to +5 VDC, -10 to +10 VDC, or -20 to +20 mA
Update Time:	5.9 mSec no filtering 8.2 mSec digital filtering enabled
Digital Filtering Time Constant:	25 mSec
DC Input Resistance:	Voltage Mode: 680 k Ω Current Mode: 250 Ω
Repeatability:	0.008%
Accuracy:	Voltage Mode: 0.10% of full scale at 25°C 0.30% of full scale at 0-60°C Current Mode: 0.20% of full scale at 25°C 0.40% of full scale at 0-60°C
Resolution:	Unipolar: 14 bit plus sign 0-5 VDC range=0.3125 mV/step 0-10 VDC range=0.625 mV/step 0-20 mA range=1.25 μ A/step Bipolar: 13 bit plus sign +5 to -5 VDC=0.625 mV/step +10 to -10 VDC range=1.25 mV/step -20 to +20 mA range=2.5 μ A/step
Common Mode Rejection:	>86db @ 60Hz (digital filtering disabled)
Normal Mode Rejection:	>45db @ 60Hz (digital filtering enabled)
Input Protection:	Input ESD Protection: 4,000 V Overrange Protection: 500 V
Isolation:	1500 VDC channel-to-PLC
Module Size:	Single wide
Backplane Power Consumption:	5.0 Watts
Humidity, Relative:	5% to 95% (non-condensing)
Shipping Weight:	1.5 lbs. (0.68 Kg)
Agency Approvals:	UL, UL for Canada, FM (Class I, Div 2)

Specifications subject to change without notice.

JUMPER SETTINGS LOG SHEET

CHANNEL NUMBER	VOLTAGE CURRENT JUMPER	JUMPER POSITION V or I	VOLTAGE RANGE JUMPER	JUMPER POSITION 5V or 10V	UNIPOLAR BIPOLAR JUMPER	JUMPER POSITION UNI or BIP
1	JP 1	1	JP 5		JP 5	
2		2	JP 6		JP 6	
3		3	JP 7		JP 7	
4		4	JP 8		JP 8	
5	JP 2	5	JP 9		JP 9	
6		6	JP 10		JP 10	
7		7	JP 11		JP 11	
8		8	JP 12		JP 12	
9	JP 3	9	JP 13		JP 13	
10		10	JP 14		JP 14	
11		11	JP 15		JP 15	
12		12	JP 16		JP 16	
13	JP 4	13	JP 17		JP 17	
14		14	JP 18		JP 18	
15		15	JP 19		JP 19	
16		16	JP 20		JP 20	

ALL CHANNELS	UNIPOLAR BIPOLAR SWITCHES	VOLTAGE RANGE SWITCHES	DIGITAL FILTERING JUMPER	JUMPER POSITION FIL/none
1-16	SW 7 SW 8	SW 5 SW 6	JP 121	FIL

Figure 21 Jumper Settings Log

Record the configuration jumper settings on this log for future reference. Make additional copies if necessary.

USER NOTES

LIMITED PRODUCT WARRANTY

CTI warrants that this CTI Industrial Product shall be free from defects in material and workmanship for a period of one (1) year after purchase from CTI or from an authorized CTI Industrial Distributor. This CTI Industrial Product will be newly manufactured from new and/or serviceable used parts which are equal to new in the Product.

Should this CTI Industrial Product fail to be free from defects in material and workmanship at any time during this one (1) year warranty period, CTI will repair or replace (at its option) parts or Products found to be defective and shipped prepaid by the customer to a designated CTI service location along with proof of purchase date and associated serial number. Repair parts and replacement Product furnished under this warranty will be on an exchange basis and will be either reconditioned or new. All exchanged parts or Products become the property of CTI. Should any Product or part returned to CTI hereunder be found by CTI to be without defect, CTI will return such Product or part to the customer.

This warranty does not include repair of damage to a part or the Product resulting from: failure to provide a suitable environment as specified in applicable Product specifications, or damage caused by an accident, disaster, acts of God, neglect, abuse, misuse, transportation, alterations, attachments, accessories, supplies, non-CTI parts, non-CTI repairs or activities, or to any damage whose proximate cause was utilities or utility like services, or faulty installation or maintenance done by someone other than CTI.

Control Technology Inc. reserves the right to make changes to the Product in order to improve reliability, function, or design in the pursuit of providing the best possible Product. CTI assumes no responsibility for indirect or consequential damages resulting from the use or application of this equipment.

THE WARRANTY SET FORTH ABOVE IN THIS ARTICLE IS THE ONLY WARRANTY CTI GRANTS AND IT IS IN LIEU OF ANY OTHER IMPLIED OR EXPRESSED WARRANTY OR WARRANTY ON CTI PRODUCTS, INCLUDING WITHOUT LIMITATION, ANY WARRANTY OF MERCHANTABILITY OR OF FITNESS FOR A PARTICULAR PURPOSE AND IS IN LIEU OF ALL OBLIGATIONS OR LIABILITY OF CTI FOR DAMAGES IN CONNECTION WITH LOSS, DELIVERY, USE OR PERFORMANCE OF CTI PRODUCTS OR INTERRUPTION OF BUSINESS, LOSS OF USE, REVENUE OR PROFIT. IN NO EVENT WILL CTI BE LIABLE FOR SPECIAL, INCIDENTAL, OR CONSEQUENTIAL DAMAGES.

SOME STATES DO NOT ALLOW THE EXCLUSION OR LIMITATION OF INCIDENTAL OR CONSEQUENTIAL DAMAGES FOR CONSUMER PRODUCTS, SO THE ABOVE LIMITATIONS OR EXCLUSIONS MAY NOT APPLY TO YOU.

THIS WARRANTY GIVES YOU SPECIFIC LEGAL RIGHTS, AND YOU MAY ALSO HAVE OTHER RIGHTS WHICH MAY VARY FROM STATE TO STATE.

REPAIR POLICY

In the event that the Product should fail during or after the warranty period, a Return Material Authorization (RMA) number can be requested verbally or in writing from CTI main offices. Whether this equipment is in or out of warranty, a Purchase Order number provided to CTI when requesting the RMA number will aid in expediting the repair process. The RMA number that is issued and your Purchase Order number should be referenced on the returning equipment's shipping documentation. Additionally, if under warranty, proof of purchase date and serial number must accompany the returned equipment. The current repair and/or exchange rates can be obtained by contacting CTI's main office at 1-800-537-8398.

When returning any module to CTI, follow proper static control precautions. Keep the module away from polyethylene products, polystyrene products and all other static producing materials. Packing the module in it's original conductive bag is the preferred way to control static problems during shipment. **Failure to observe static control precautions may void the warranty.** For additional information on static control precautions, contact CTI's main office at 1-800-537-8398.