

CTI 2500 Series[®] Controller
INSTALLATION AND OPERATION GUIDE

Version 2.15

CTI Part # 062-00370

**Copyright 2022 Control Technology Inc.
All rights reserved.**

This manual is published by Control Technology Inc. (CTI) 5734 Middlebrook Pike, Knoxville, TN 37921. This manual contains references to brand and product names which are tradenames, trademarks, and/or registered trademarks of Control Technology Inc. Siemens®, SIMATIC®, and Series 505®, and 505® are registered trademarks of Siemens AG. Other references to brand and product names are tradenames, trademarks, and/or registered trademarks of their respective holders.

DOCUMENT DISCLAIMER STATEMENT

Every effort has been made to ensure the accuracy of this document; however, errors do occasionally occur. CTI provides this document on an “as is” basis and assumes no responsibility for direct or consequential damages resulting from the use of this document. This document is provided without express or implied warranty of any kind, including but not limited to the warranties of merchantability or fitness for a particular purpose. This document and the products it references are subject to change without notice. If you have a comment or discover an error, please call us toll-free at 1-800-537-8398 or email us at sales@controltechnology.com.

REVISION HISTORY		
V 1.0	6/28/07	Initial Release
V 1.1	10/30/07	Defined additional Profibus status bits for STW231. Added fatal error code for hardware watchdog event. Added information regarding the IPSET utility. Added a caution to avoid duplicate IP addresses. Changed fatal error section to reflect that the fatal error code will be displayed on the MSD.
V1.2		Corrected error describing STW162 bit 12.
V1.3	4/29/08	Documented STW 455 – STW 501. Revised Section regarding Ethernet TCP/IP to improve clarity. Revised Appendix C to improve clarity. Revised description of SW6 usage to improve clarity.
V1.4	6/30/08	Added section for user flash operation
V1.5	10/8/08	Corrected erroneous status word bit reference in non-fatal error table. Added instructions for selecting PRINT jumper Added STW191 use for serial port print error reporting.
V1.6	12/1/08	Changed error codes containing a B or D to lower case b or d to correspond to multi-segment display. Added firmware update status code table.
V1.7	2/25/09	Added a comment requiring all reserved switches to be set to the closed position.
V1.8	5/11/09	Added specification of serial port parity, data bits, and stop bits. Added instructions for upgrading firmware using the SD card. Added description of the duplicate IP detection feature.
V1.9	6/11/09	Added specifications and handling instructions for the lithium battery

REVISION HISTORY		
V1.10	9/16/09	Revised Profibus DP cabling specifications to be expressed in meters rather than feet. Added Belden Hi-Flex cable to recommended Profibus DP cabling. Added specifications for maximum number of DP Profibus slaves and maximum number of slots per slave.
V1.11	11/10/09	Added specifications for the amount of data per Profibus slave and slots per Profibus slave supported by the 2500 controller.
V1.12	11/30/09	Corrected specifications for STW191.
V1.13	2/15/10	Added warning for use of USB port in hazardous environments. Added section describing system restart options.
V1.14	3/16/10	Revised text to reflect new features introduced in firmware V6.07. <ul style="list-style-type: none"> • new status bits in STW244 and STW245, • fatal error code in STW246, • automatic IP address assignment, • capability to change IP address in Run mode, • expansion of modular slave slots supported from 64 to 128, Added a section on Profibus operation to explain Profibus operational and synchronization modes and to highlight diagnostic capabilities. Corrected serial port pinout diagram in Appendix E.
V1.15	9/21/10	Revised text to reflect new Profibus slave status bit in STW321 (added in firmware V6.11).
V1.16	11/17/10	Provided more detail regarding startup errors E9 – E14
V1.17	1/10/10	Corrected error specifying status words for product serial number.
V1.18	5/5/11	Added new error code 102 to the list of fatal errors. Corrected a corrupted cross-reference on page 47.
V1.19	9/20/11	Added documentation for dual RBC support Revised remote I/O topology drawings to better illustrate dual RBC connectivity. Updated product pictures to reflect latest front panel overlay. Enhanced battery specifications in Appendix B. Deleted battery specification in product model table.
V1.20	4/21/13	Added documentation for new functionality enabled by Switch 7 and 8. Revised text regarding switches and jumpers to improve clarity.
V1.21	4/25/14	Modified switch drawing to include SW7 and SW8 Revised text to correct typographic errors and improve clarity Updated SD card documentation
V1.22	6/26/14	Added documentation regarding support of additional control relays. Added table indicating retentive and non-retentive control relay addresses. Modified installation instructions to reflect that the controller battery is now shipped with the battery installed. Created a Battery Replacement appendix.
V1.23	7/28/14	Clarified SD card requirements. Added an SD Requirements appendix.
V1.24	4/8/15	Added a list of all task code errors.
V1.25	6/23/15	Revised the description of the serial port (section 7.2) to include use as a printer port.
V1.26	9/10/15	Revised documentation to include new features added in firmware version 8.02. (Ethernet port IP address change, embedded web server IP configuration page, reset to factory default, display subnet in CIDR format). Added sections to Installation chapter regarding setting IP address and automatic IP address assignment.

REVISION HISTORY		
V1.27	9/17/15	Corrected error in Appendix C; CIDR notation for subnet mask 255.255.240.0.
V1.28	11/30/15	Corrected error in firmware update error table for error E30 Revised text for firmware update error E31 to improve clarity.
V1.29	3/1/2016	Expanded firmware update status codes to include Profibus FPGA (Rev G and above) Expanded firmware update error codes to include Profibus FPGA (Rev G and above)
V2.0	8/25/2016	Added compact PLC (2500C-Cxxx) Implemented table of contents hyperlinks
V2.1	1/3/2017	Corrected version support for TISOFT.
V2.2	1/26/17	Corrected illustration of user jumper (p26) Updated copyright date
V2.3	2/6/2017	Modified properties of user jumper illustration to correct text positioning. Added caption to open Jumper illustration.
V2.4	2/14/2017	Added inline SFP to the potential causes of fatal error 113 in Section 9.3.2.
V2.5	2/27/2017	Revised description for error E30.
V2.6	8/23/2017	Replaced dipswitch position picture for compact controller models
V2.7	12/11/2017	Added documentation for STW300 – STW330
V2.8	4/24/2018	Added a note to Appendix B stating that status words 243 and above are not supported by Siemens 505 controllers. Revised note in Firmware Update section that appeared to limit supported SD cards to 4GB and below
V2.9	10/8/2018	Changed description of STW 1, bit 13 to unused.
V2.10	12/3/2018	Added description of STW267
V2.11	8/25/2020	Added caution regarding use of battery specified for Janus controller instead of the battery specified for the 2500 Series PLC
V2.12	11/12/2020	Added description for STW332-STW335
V2.13	1/13/2021	Updated warnings for USB port and battery
V2.14	11/15/2021	Updated firmware update error table to indicate that error E74 could be caused by a bad SD card.
V2.15	11/1/2022	Added a note to section 4.4.3 indicating that Profibus alarms are not supported by 2500 Series controllers.

PREFACE

This ***Installation and Operation Guide*** provides reference information for CTI 2500 Series Classic controllers and CTI 2500 Series Compact controllers. The information in this manual is directed to individuals who will be installing and operating the controller as well as those who will be designing systems that use the controller.

For comprehensive programming information, you should also obtain the *CTI 2500 Programming Reference Manual* (CTI Part # 062 -00371).

USAGE CONVENTIONS

NOTE

Notes alert the user to special features or procedures.

CAUTION

Cautions alert the user to procedures that could damage equipment.

WARNING

Warnings alert the user to procedures that could damage equipment and endanger the user.

TABLE OF CONTENTS

CHAPTER 1 OVERVIEW	11
1.1 Introduction	11
1.2 Controller Features	11
1.3 User Program Support.....	11
1.4 I/O Support.....	12
1.5 Ethernet TCP/IP Connectivity	12
1.6 Programming Support	12
1.7 Serial and USB Connectivity	13
1.8 2500 Series Classic Controller Front Panel.....	14
1.9 2500 Series Compact Controller Front Panel.....	15
1.10 Operational Status LEDs.....	16
1.11 Multi-Segment Display.....	16
1.12 Battery Holder	16
1.13 SD Flash Card Slot.....	16
1.14 USB Port	16
1.15 Ethernet Status Indicators	17
1.16 Ethernet Port.....	17
1.17 RS-232/ RS-422 Serial Port	17
1.18 Profibus-DP Port.....	17
1.19 I/O Port.....	17
1.20 Product Models.....	18
CHAPTER 2 INSTALLATION.....	19
2.1 Installation Planning.....	19
2.2 Unpacking the Controller	21
2.3 Setting the User Switches	22
2.4 Setting the User Jumpers or Auxiliary Switches.....	26
2.5 Physical Installation	28
2.6 Initial Power On.....	28
2.7 Setting the Controller IP Parameters	29
2.8 Automatic IP Address Assignment.....	29
CHAPTER 3 USER PROGRAMMING	31
3.1 Overview	31
3.2 Relay Ladder Programming	31
3.3 Special Function Programs and Subroutines	32
3.4 Analog Loops.....	33
3.5 Analog Alarms.....	33
CHAPTER 4 I/O SUPPORT	35
4.1 I/O Concepts	35
4.2 I/O Support.....	36
4.3 Dual RBC Support	39
4.4 Profibus DP I/O	41

CHAPTER 5 CONTROLLER MEMORY	47
5.1 Overview	47
5.2 User Program RAM	47
5.3 Flash Memory	49
5.4 High Speed DRAM	49
CHAPTER 6 SCAN TIMELINE	51
6.1 Scan Overview	51
6.2 PLC Scan Types	53
6.3 Scan Modes	54
CHAPTER 7 COMMUNICATIONS.....	57
7.1 Overview	57
7.2 Serial Communications.....	57
7.3 USB Communications	57
7.4 Ethernet Communications	58
CHAPTER 8 SYSTEM RESTART OPTIONS	63
8.1 Overview	63
8.2 Restart Options	63
8.3 System Restart Table	64
CHAPTER 9 TROUBLESHOOTING.....	65
9.1 Troubleshooting Aids	65
9.2 Startup Errors.....	65
9.3 Fatal Errors	66
9.4 Non-Fatal Errors	70
CHAPTER 10 UPDATING FIRMWARE.....	73
10.1 Overview	73
10.2 Serial Port Method	73
10.3 SD Card Method	77
10.4 Firmware Update Status Codes	78
10.5 Firmware Update Errors	79
CHAPTER 11 USER PROGRAM FLASH STORAGE.....	81
11.1 Overview	81
11.2 Using Flash Memory	82
11.3 Power-On Start Operation	83
11.4 Restrictions When the Program Source is Flash.....	83
APPENDIX A. - ERROR CODES	85
Startup Error Codes.....	85
Fatal Error Codes	86
Task Code Errors.....	88
APPENDIX B. – SYSTEM STATUS WORDS	91
APPENDIX C. – IP ADDRESS INFORMATION.....	101
IP Address Nomenclature	101
Selecting IP Addresses	102

APPENDIX D. – COMPATIBILITY	105
Overview	105
Relay Ladder Logic.....	105
Special Function Programs	105
User Configuration.....	106
I/O Support.....	106
APPENDIX E. – BATTERY REPLACEMENT	107
APPENDIX F. – PRODUCT SPECIFICATIONS.....	109
Hardware Specifications.....	109
Serial Port Pinout.....	109
I/O Port Pinout	110
Profibus Port Pinout.....	110
APPENDIX G. – SD CARD REQUIREMENTS.....	111
CTI 2500 Series Classic Controller SD Card Requirements	111
CTI 2500 Series Compact Controller SD Card Requirements	111
Data Storage Capacity	111
Physical Size.....	111
Speed	111
LIMITED PRODUCT WARRANTY	113
REPAIR POLICY	115

CHAPTER 1 OVERVIEW

1.1 Introduction

Providing the capabilities of a programmable logic controller and a loop controller, the CTI 2500 Series® controllers offer solutions for a wide range of process control applications. The CTI 2500 Series includes two families, CTI 2500 Series Classic and CTI 2500 Series Compact.

- **Classic:** 2500 Series Classic controllers (2500-Cxxx) are physically compatible with the Siemens SIMATIC 505 product line and may be installed in a CTI 2500 Series base or a Siemens SIMATIC 505 base, along with CTI 2500 Series Classic I/O and SIMATIC 505 I/O.

CTI 2500 Series Classic controllers are also operationally compatible. They can run most user programs that were originally developed for Siemens SIMATIC 505 controllers (see APPENDIX D. – COMPATIBILITY for exceptions) and can communicate with remote bases using SIMATIC 505 or CTI 2500 Series remote base controllers.

- **Compact:** CTI 2500 Series Compact controllers (2500C-Cxxx) are physically smaller than the Classic controllers but are otherwise operationally identical to the 2500 Series Classic controllers.

1.2 Controller Features

1.3 User Program Support

User Program components include Relay Ladder Logic (RLL), Special Function programs, Analog Loops, and Analog Alarms. The User Program is stored in battery backed RAM and is preserved when power is removed from the controller, assuming the battery is good. See CHAPTER 3 for more information about user programming.

Relay Ladder Logic

CTI 2500 Series controllers incorporate a powerful RLL programming language that is compatible with the RLL used in the Siemens SIMATIC® 505 PLC. The RLL program is compiled in the controller before execution.

Special Function Programs and Subroutines

Special Function programs and subroutines introduce the capability to program in a procedural language, similar to Basic or Structured Text. This capability can be used to implement control processes that would be difficult or impossible to program in RLL.

All Special Function programs and subroutines are compiled on the controller. Where applicable, they make use of the double-precision floating point unit provided by the CTI 2500 hardware.

Special Function programs and subroutines may be called from RLL for in-line execution or queued for subsequent execution in the analog portion of the scan. Special Function programs can also be called from PID loops or Analog alarms or executed on a cyclic basis.

Analog Loops

CTI 2500 Series controllers incorporate a comprehensive, parameter-driven PID loop algorithm. PID loop calculations make use of a double-precision floating point processor. Loop calculations can be automatically executed on a specified time interval or called directly from RLL (Models 300 and 400 only). The number of PID loops supported depends on the controller model. See Section 1.20.

Coupled with the loop processing is an extensive alarm reporting capability.

Analog Alarms

The CTI 2500 controller includes analog alarm functions that can monitor the process variable and the set point. Absolute values, deviation, and rate of change can be monitored. The number of analog alarms supported varies with the controller model. See Section 1.20

1.4 I/O Support

The CTI 2500 Series controller supports CTI 2500 Series Classic I/O, CTI 2500 Series Compact I/O, Siemens SIMATIC® 505 compatible I/O and Profibus DP I/O.

SIMATIC® 505 Compatible I/O

The CTI 2500 controller supports all CTI 2500 series modules and most Siemens SIMATIC® 505 discrete and analog modules. In addition, the controller will communicate with designated Siemens SIMATIC® 505 Special Function modules. See the CTI Web site (www.controltechnology.com) for a list of supported Siemens modules.

The CTI 2500 controller also permits the attachment of remote bases using CTI 2500-RIO or CTI 2500C-RIO remote base controllers or Siemens Series 505® or Series 500® remote base controllers. See Section 4.2 for more information.

Profibus DP I/O

The CTI 2500 controller supports I/O that conforms to the Profibus DP standard, including the CTI 2500-RBC and the Siemens® 505-6870. The Profibus network can be configured using software tool shipped with your programming software.

1.5 Ethernet TCP/IP Connectivity

The CTI 2500 controller provides a local 10/100 Mb Ethernet port, allowing it to be connected to plant floor networks. Programming software that supports the TCP/IP protocol, such as FasTrak Softworks Workshop®, can be used to program the CTI 2500 via the network.

Although the primary purpose of the Ethernet port is to provide network access for programming and operating the controller, it also may be used by Supervisory Control and Data Access (SCADA) applications. Software with drivers that support the CTI 2572 or 2572-A network modules can be used with the local Ethernet port. See CHAPTER 7 for additional information.

1.6 Programming Support

To access all the features of the CTI 2500 controller, you must use PLC Workshop Version 4.11 or greater. Contact FasTrak Softworks, Inc. (262) 238-8088 to obtain this software.

The following programming software can be used; however, certain features, such as additional memory, may not be accessible:

- Siemens TISOFT® V7.1
- Siemens APT® V1.9

See the *CTI 2500 Programming Reference Manual* for additional details.

Using suitable programming software, you may edit directly the User Program stored in the controller memory. Alternately, you can program off-line and then download the program to the controller.

1.7 Serial and USB Connectivity

The CTI 2500 controller provides a traditional 9 pin serial port and a USB (Universal Serial Bus) port which may be used to program the controller and control its operation. See CHAPTER 7 for more information.

1.8 2500 Series Classic Controller Front Panel

1. Operational Status LEDs

CPU GOOD

RUN

BATTERY GOOD

2. Multi-Segment Display` (MSD)

3. Battery Holder

4. SD Card Slot

5. USB Port

6. Network LEDs

LS – Link Status

NS- Network Status

7. Ethernet Port

XMT LED – Flashes when transmitting

RCV LED – Flashes when receiving

8. Serial Communications Port

RS-232/RS-422)

9. Profibus DP Port

10. Remote I/O Port

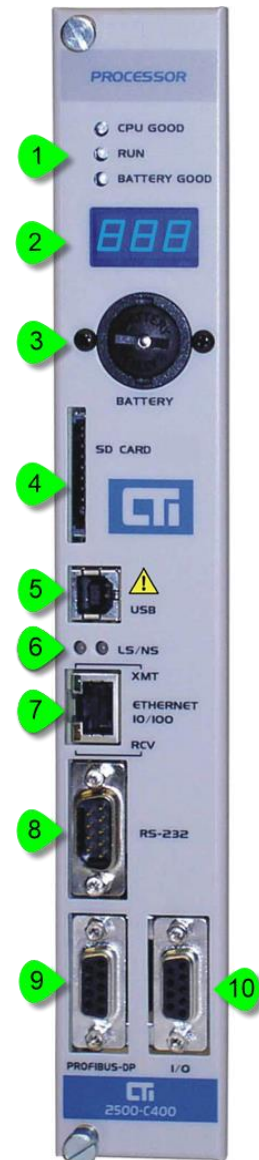

1.9 2500 Series Compact Controller *Front Panel*

1. Status LEDs

CPU GOOD

RUN

BATTERY GOOD

2. Multi-Segment Display` (MSD)

3. USB Port

4. SD Card Slot

5. Network LEDs

LS – Link Status

NS- Network Status

6. Battery Holder

7. Ethernet Port

XMT LED – Flashes when transmitting

RCV LED – Flashes when receiving

8. Serial Communications Port

RS-232/RS-422)

9. Profibus DP Port

10. Remote I/O Port



1.10 Operational Status LEDs

The following LEDs provide status information:

CPU Good	When this LED is on, the controller is operational. When this LED is off, power is not present or a startup or fatal error exists. See CHAPTER 9.
Run	When this LED is on, the controller is in RUN mode. When this LED is off, the controller is in PROGRAM mode. When this LED is blinking, the RLL execution is in PROGRAM mode and the Analog execution is in RUN mode.
Battery Good	When this LED is on, the battery is good. When this LED is off, the battery is bad or missing or the battery switch is Off. When this LED is blinking, this LED indicates that the battery is marginal and should be replaced.

1.11 Multi-Segment Display

The Multi-Segment Display (MSD) is used to display status and error codes (see CHAPTER 9). During normal operation it will display the TCP/IP address, one octet at a time. Firmware Version 8.02 and above firmware also displays the network mask in CIDR (Classless Inter-Domain Routing) format following the IP Address. See APPENDIX C. – IP ADDRESS INFORMATION for more information about CIDR format.

1.12 Battery Holder

The battery holder contains the battery that maintains the User Program and related data when the controller is not powered. The battery may be replaced while the controller is installed and powered, eliminating the need to re-program the controller after swapping the battery.



WARNING

See APPENDIX E. – BATTERY REPLACEMENT regarding replacement.

1.13 SD Flash Card Slot

2500 Series Classic controllers accommodate a standard SD or SDHC card. 2500 Series Compact controllers accommodate a micro SD or micro SDHC card. The SD card may be used to upgrade the controller firmware. See APPENDIX G. – SD CARD REQUIREMENTS.

1.14 USB Port

The CTI 2500 controller provides a type B USB (Universal Serial Bus) connector. The port can be used to program the controller. A special PC driver that emulates a standard COM port is required. See Section 7.3 for additional information.



WARNING

The USB Port is for temporary connection only.

Do not use, connect, or disconnect the USB cable unless area is known to be non-hazardous. Connection or disconnection in an explosive atmosphere could result in an explosion.

1.15 Ethernet Status Indicators

LS – Link Status	When this LED is on, an Ethernet link has been established.
NS – Network Status	When the network is operating normally, the LED color will be GREEN. If a network device with the same IP address as the Ethernet port is detected, this LED will be RED.

1.16 Ethernet Port

The Ethernet port allows you to connect the controller directly to an Ethernet network using a standard RJ-45 connector. The port automatically selects between 10bT and 100bTX Ethernet and between half or full duplex, depending on speed of the device to which it is connected. Two status indicators that display Ethernet traffic are embedded into the connector.

TX- Transmit	Flashes when the port transmits an Ethernet packet.
RX- Receive	Flashes when the port receives an Ethernet packet. *

**Ethernet packets received by the port do not necessarily contain data for the controller.*

See Section 7.4 for information regarding use of the Ethernet port.

1.17 RS-232/ RS-422 Serial Port

The serial port can support either an RS-232 or an RS-422 electrical interface. When the RS-232 electrical interface is selected, you can connect to the RS-232 serial port on your PC using a standard null modem cable or cables that are currently used with the Siemens Series 505[®] controllers. For longer cable runs, you can select the RS-422 electrical interface, which is supported by some operator interface equipment.

The electrical interface and port baud rate via a set of user switches on the controller circuit board. See Section 2.3 for further information regarding the user switches. The other port parameters have constant values: Parity = Odd, Data Bits = 7, and Stop Bits = 1.

Normally, the serial port is used for programming and data access. However, you can change the function of the port to a printer port (output only) by repositioning a jumper on the printed circuit board (see Section 2.4). You can then use the PRINT statement to send a character string to the printer our output device. See the *CTI 2500 Series Programming Reference Manual* for additional information.

If your application requires a custom cable, see APPENDIX F. – PRODUCT SPECIFICATIONS for the port pinout.

1.18 Profibus-DP Port

This port allows you to connect the controller to a standard Profibus-DP network. See CHAPTER 4 for more information on using Profibus and APPENDIX F. – PRODUCT SPECIFICATIONS for the port pinout.

1.19 I/O Port

The I/O port enables you to connect CTI 2500 Series and SIMATIC Series 505[®] Remote I/O. See CHAPTER 4 for additional information regarding remote I/O support and APPENDIX F. – PRODUCT SPECIFICATIONS for the port pinout.

1.20 Product Models

The CTI 2500 Classic controller (2500-Cxxx) is available in four models. The CTI 2500 Compact (2500C-Cxxx) controller is available in three models. The following table lists the model characteristics.

Feature	2500-C100 2500C-C100	2500-C200 2500C-C200	2500-C300 2500C-C300	2500-C400
User Program RAM	128K	256K	512K	3072K
Discrete I/O Points	1024	2048	8192	8192
Word I/O Points	1024	1024	8192	8192
Control Relays	4096	32,768	32,768	32,768 ^{See Note 1}
Retentive Control Relays	1024	4096	4096	4096
Timers/Counters	1024	20,480	20,480	20,480
Compiled SF	Yes	Yes	Yes	Yes
Cyclic PID Loops	16	64	128	128
RLL Initiated PID Loops (Fast Loops)	0	0	384	384
Analog Alarms	32	128	512	512
Special Function Programs	64	1023	1023	1023
Special Function Subroutines	64	1023	1023	1023
Remote IO	None	15 bases	15 bases	15 bases
Profibus I/O	None	Up to 112 devices	Up to 112 devices	Up to 112 devices
Maximum Serial Port Data Rate	115,200 baud	115,200 baud	115,200 baud	115,200 baud
Flash O/S	Yes	Yes	Yes	Yes
Removable User Storage	SDHC Card - Up to 32GB	SDHC Card - Up to 32GB	SDHC Card - Up to 32GB	SDHC Card - Up to 32GB
On Board User Flash	Yes	Yes	Yes	Yes
Local Ethernet Port	Yes	Yes	Yes	Yes
USB Port	Yes	Yes	Yes	Yes
Remote I/O	No	Yes	Yes	Yes
Profibus I/O	No	Yes	Yes	Yes

Note 1: CTI 2500 Classic controller model C400 with firmware version 8.01 and above support 56,320 control relays. See Section 5.2.3 for more information.

CHAPTER 2 INSTALLATION

The installation of the CTI 2500 Controller consists of the following steps:

- 1) Reading this Chapter
- 2) Planning the installation,
- 3) Unpacking and configuring the module,
- 4) Physical installation,
- 5) Connecting cables,
- 6) Checking the controller operation.

2.1 Installation Planning

2.1.1 Safety Considerations

Before installing the controller, you must identify the personnel hazards that may be created in the event of a system failure and provide interlocks and safety switches to prevent operation during a system failure. Refer to the NEMA ICS 3-304 Programmable Control Standards.

WARNING

As a system designer, you should be aware that Control devices can fail in an unsafe condition. Unless you incorporate proper safeguards, malfunction of the controller or associated devices, such as operator interface equipment, could cause sudden equipment startup, shutdown, or other unexpected operation. Such startup or shutdown or unexpected operation could result in death or serious injury to personnel, and/or damage to equipment.

If you or your company are using CTI controllers with equipment that requires the presence of a person (such as an operator or attendant), you should be aware of this potential safety hazard and take appropriate precautions.

The precautions below conform to the National Electrical Manufacturers Association guidelines for installation of programmable controllers as recommended in the NEMA ICS 3–304 Programmable Control Standards.

ICS 3-304.81 Safety Recommendations:

Consideration should be given to the use of an emergency stop function which is independent of the programmable controller. Where the operator is exposed to the machinery, such as in loading or unloading a machine tool, or where the machine cycles automatically, consideration should be given to the use of an electromechanical override or other redundant means, independent of the programmable controller, for starting and interrupting the cycle. If provision is required for changing programs while the equipment is in operation, consideration should be given to the use of locks or other means of assuring that such changes can be made only by authorized personnel. These recommendations are intended as safeguards against the failure of critical components and the effects of such failures or the inadvertent errors that might be introduced if programs are changed while the equipment is in operation.

Operator Safety Switches

Power should be configured so that it can be manually removed from all output devices. You must provide a method that is independent of the control system for disconnecting power from the outputs when a machine is not operating or the operator must reach into the machine. A non-electronic switch or directly wired relay must be used to disconnect the power.

Emergency Stop Switch

You must provide a method for disconnecting power from the outputs if an emergency situation is encountered with the machine operation. Use a non-electronic switch or relay that is wired external to the controller and that is easily accessible.

2.1.2 Electrical Interference

Electrical interference can adversely affect the operation of control equipment. The major sources of electrical interference in an industrial environment are devices that use high voltages and current, such as motors and welders. Electrical interference can be conducted directly through wiring or inducted via electromagnetic coupling.

To ensure a reliable control system, you will need to determine the source of the electrical interference and employ suitable techniques to eliminate it.

2.1.3 Grounding

It is very important that the all equipment is properly grounded. Lack of proper grounding may cause intermittent or erratic operation or may cause the control system to fail. A properly installed grounding system will provide a low-impedance path to earth ground, which will give all PLC internal filtering devices a good ground return for reference. The earth ground of the building site typically provides reliable grounding; however, if excessive ground current is present, a separate grounding electrode should be installed.

A common practice is to provide a central ground bus bar as a single point of reference within each enclosure, connecting all chassis and power supply components to the bus bar. The bus bar is then connected to earth ground. When connecting to the bus bar, use 1 inch copper braid or No. 8 AWG wire. To ensure good connections, scrape paint or other non-conductive coatings away from mounting studs and from enclosure surfaces where mounting bolts and washers make contact.

In addition to connecting the controller rack and power supply to earth ground, you must ensure that the power supply, controller and all modules installed in the base are installed securely and that the thumbscrews are tightened.

2.1.4 Choosing the IP Address and related Parameters

Before you can use the Ethernet port, you must set the IP address, network mask, and the default router. If you already have a network installed, you should contact your network administrator to determine the values to be used. See APPENDIX C. – IP ADDRESS INFORMATION for more information on choosing an IP address. The IP address can be set via the serial or USB port using PLC Workshop (version 4.11 and above) or by IPSET, a utility program provided by CTI. Firmware version 8.02 and above allows you to set the IP address via the Ethernet port using PLC workshop or the controller embedded web server. See Section 7.4 for additional information.

2.1.5 Power Requirements

The CTI 2500 module consumes 5.5 watts of +5 VDC power. To calculate the total power required for the base, you need to add the power requirements for the other modules you will install in the base.

2.2 Unpacking the Controller

Open the shipping carton and remove the special anti-static bag that contains the controller. After discharging any static build-up, remove the unit from the static bag. Do not discard the static bag; use it for protection against static damage when the module is not inserted into the I/O base.

CAUTION

The components on the CTI 2500 controller printed circuit card can be damaged by static electricity discharge. To prevent this damage, the module is shipped in a special anti-static bag. Static control precautions should be followed when removing the module from the bag and when handling the printed circuit card during configuration.

2.3 Setting the User Switches

The switchblock containing the user switches is located on the circuit board as shown in the picture below.

2.3.1 User Switch Locations

CTI 2500 Classic Controller

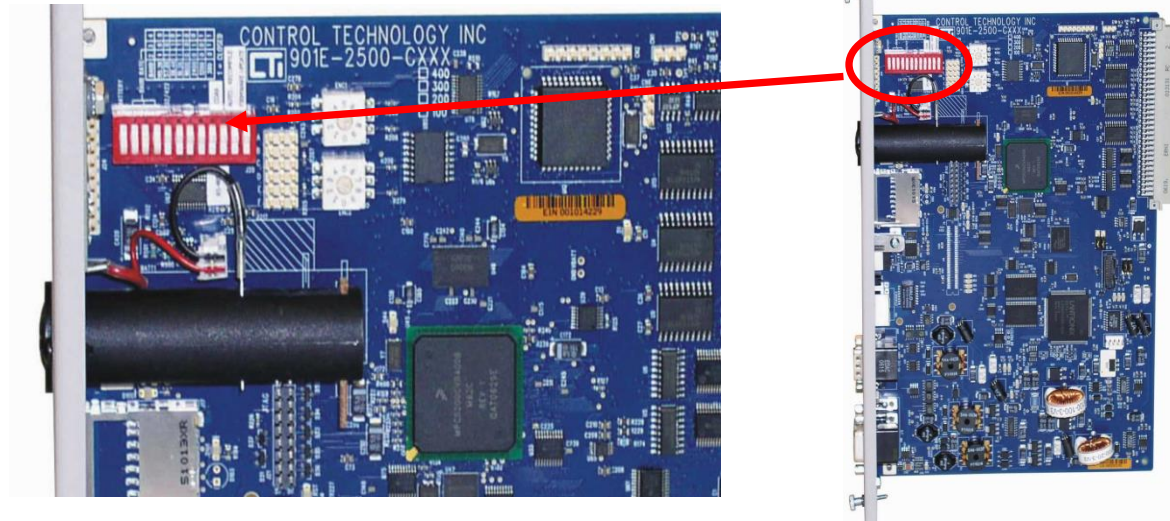

CTI 2500 Compact Controller

The switchblock containing the user switches is on the display board behind the front panel on the switchblock labelled ENC1. See accompanying picture.

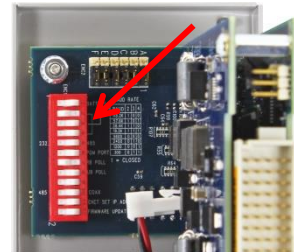

2.3.2 User Switch Functions

SW1: Battery Switch

The battery switch is used to connect and disconnect the battery. The battery is connected when the switch is in the **CLOSED (ON)** position and disconnected when the switch is in the **OPEN (OFF)** position.

NOTE:

*2500 Series controllers are shipped with the battery switch in the **Open** (disconnected) position. To enable battery backup, you must place the battery switch in the **Closed** (connected) position.*

SW2 - SW4: Serial Port Baud Rate.

Switches 2 through 4 are used to set the baud rate for the serial port as indicated in the table below.

Baud Rate	Switch Position		
	SW2	SW3	SW4
115,200	Closed (On)	Open (Off)	Open (Off)
57,600	Closed (On)	Open (Off)	Closed (On)
38,400	Closed (On)	Closed (On)	Open (Off)
19,200	Closed (On)	Closed (On)	Closed (On)
9,600	Open (Off)	Open (Off)	Open (Off)
2400	Open (Off)	Closed (On)	Open (Off)
1200	Open (Off)	Open (Off)	Closed (On)
300	Open (Off)	Closed (On)	Closed (On)

SW5: Serial Port Electrical Interface

This switch selects whether the RS-232 electrical interface or RS-422 electrical interface is used. For typical programming applications you should select RS-232. The **OPEN (OFF)** position selects RS-232. The **CLOSED (ON)** position selects RS-422.

SW6: Program Port Selection

This switch selects whether only TCP port 4452 can be used for programming or whether TCP ports 1505 and 4450 can also be used for this purpose.

When the switch is in the **OPEN (OFF)** position, only TCP Port 4452 can be used to modify the user program via the local Ethernet port. Requests from TCP ports 1505 or 4450 can display the user program but attempts to modify the User Program will be rejected.

When the switch is in **CLOSED (ON)** position, TCP ports 4452, 1505, or 4450 can be used for all programming functions, including modifying the User Program.

This switch is provided because some Ethernet programming interfaces, such as APTNet use a fixed port number of 1505 and cannot use port 4452 for programming.

NOTE:

The switch setting applies to the local Ethernet port only and does not affect programming via Special Function modules, such as the 2572- A or 2572.

When possible, you should use set the switch to the **OPEN (OFF)** position. This setting allows you to block other users from concurrently modifying the user program by enabling Port Lockout while you are programming on this port. Port Lockout will prevent users connected to other physical ports (such as the serial port or a Special Function module) from modifying the User Program. Other users connected to Port 1505 or 4450 on the local Ethernet port cannot modify the user program because attempts to modify the user program will be rejected.

If you choose to allow port 1505 and 4450 to be used for programming (switch in the closed position), the CTI 2500 controller cannot prevent concurrent network programming. Even if Port Lockout is enabled on the local Ethernet port, multiple programming stations connected to port 1505 or 4450 on the local port will be allowed to modify the user program. See Section 7.4 for additional information.

SW7: Redundant Base Polling (firmware version 7.07 and above)

Switch 7 allows you to reduce the I/O scan time of the CTI 2500 controller in I/O configurations that use only one Remote Base Controller (RBC) per base. When the switch is set to the **CLOSED (ON)** position, the CTI 2500 controller will not poll the standby RBC in each base. This eliminates the timeout delay introduced by polling an RBC that is never present. If Switch 7 is in the **OPEN (ON)** position, the CTI controller will always poll the standby RBC.

CAUTION:

If you are using an I/O configuration that uses redundant RBCs (two RBCs per base), the switch must be in the OPEN position for the redundancy function to work properly.

SW8: Unconfigured Base Polling (firmware version 7.07 and above)

Switch 8 allows you to reduce the I/O scan of the CTI 2500 controller by not polling bases that are enabled but unconfigured. This capability is especially important for APT users needing to reduce scan time, since APT programming software does not provide a means to manually disable a base.

When Switch 8 is set to the **CLOSED (ON)** position, unconfigured bases will not be polled. When the switch is in the **OPEN (OFF)** position, all enabled I/O bases will be polled, regardless of their configuration state.

SW9: Reserved

Switch 9 is reserved for future use. This switch should be set to the **OPEN (OFF)** position.

SW10: Remote I/O Connection

Switch 10 is used to select between an RS-485 connection and a coax connection. Set the switch to the **OPEN (OFF)** position (RS-485) if you are connecting to the Remote Base Controllers via RS-485 twisted pair. Set the switch to the **CLOSED (ON)** position (Coax) if you are connecting to the RBC via a coaxial cable using a Coax modem.

NOTE

If you set this switch to the Coax position while you are connecting via RS-485 the remote I/O may function correctly but the update time will be significantly longer.

If you set the switch to the RS-485 position while you are using a coax modem, the remote I/O will not work.

SW11: Ethernet Port IP Address Change Enable

This switch controls whether the IP parameters (IP Address, Subnet Mask, and Default Gateway) can be changed via the local Ethernet port. In the **OPEN (OFF)** position changing the IP parameters via the Ethernet port is prohibited. In the Closed position, PLC Workshop or the embedded web server can be used to change the parameters.

SW12: Firmware Update

Occasionally, you may need to update the controller firmware to add functionality or correct problems. Switch 12 is used to enter the firmware update state. When the switch is in the **OPEN (OFF)** position, the controller will start up in the normal operating mode. When the switch is **CLOSED (ON)** position, the controller will start up in the firmware update mode. See CHAPTER 10 for information about updating the controller firmware.

2.4 Setting the User Jumpers or Auxiliary Switches

2500 Series Classic Controllers

Similar in function to the user switches, user jumpers allow you to modify the operation of the controller. User Jumpers are labeled A – F. Jumpers are used instead of a switches where the modified behavior is not commonly used or to prevent the user from inadvertently selecting the modified behavior.

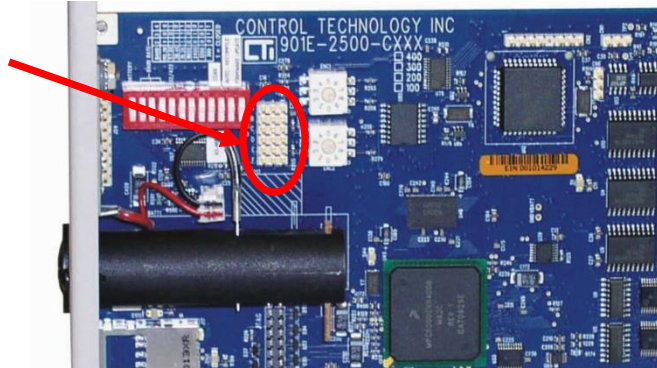

The user jumpers are located next to the user switches (labeled as J20). A jumper is **OPEN** when the jumper is not installed or is located in the right hand position. A jumper is **CLOSED** when the jumper is in the left hand position. See the illustration below.



2500 Series Compact Controllers

CTI 2500 Series Compact Controller use a set of Auxiliary Switches, located next to the User switches, instead of jumpers. The switches are numbered 1 – 6. The **ON** position is equivalent to the **CLOSED** jumper position.

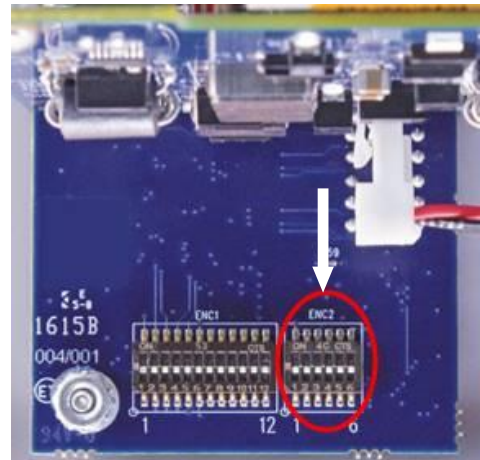

Jumper Switch	Use	Open Off	Closed On	Comments
A or 1	Selects whether the controller reports SIMATIC 505 model-equivalent memory capacity or APT Expanded Memory capacity when queried by task code 6D.	SIMATIC 505 Model Equivalent Memory	APT Expanded Memory See Note 1 below	APT Expanded Memory Mode will not work properly with legacy 505 Workshop versions. Changes to APT files are required to use the larger APT Expanded Memory and additional control relays.. Contact CTI.
B or 2	Selects the Serial Port function.	The serial port functions as a programming port	The serial port functions as a printer port	When the serial port is selected as a "Printer Port" it will not respond to task code or other requests. It is output only.
C or 3	Ethernet Port Auto-Crossover Enable	Auto-Crossover is Disabled. The port uses MDI mode	Auto-Crossover is enabled	The Ethernet port operates most reliably in MDI mode. In MDI mode the port can connect to switches and hubs using a standard straight-thru cable and all other devices that support that support auto-crossover capability. Auto-crossover should be enabled on the processor Ethernet port only in exceptional cases.
D or 4	Used to clear all IP Parameters (IP address, subnet mask, and default router/gateway. (See Section 7.4.3)	No action	Clears the IP parameters during power up start.	After clearing the IP Parameters, placing the jumper in the Open position and re-powering the controller will automatically generate a temporary link local address, which can be used to set a permanent static address.
E or 5	Reserved			Jumpers should be in the Open position Auxiliary switches be in the Off position
F or 6	Reserved			

Note 1: Model C400 controllers with firmware version 8.01 and above will also report additional control relays (C32769 – C56320) when Jumper A is closed.

2.5 Physical Installation

Remove AC power from the rack. Align the circuit board with the connector next to the power supply. Slide the controller into the rack until the connector seats. Use the thumbscrews to secure the controller in the rack.



WARNING

Do not install or remove the controller while line power is applied. It can damage the controller or other equipment and could cause injury or death.

2.6 Initial Power On

Apply power to the base power supply. The Power Good LED on the power supply should illuminate, indicating that power is being supplied to the base connectors. The controller will take a few seconds to complete the startup sequence. When this is complete, the status indicators should be in the following state:

Indicator	State	Comments
CPU Good	ON	If the CPU Good LED is off, check the Multi-Segment Display (MSD). If the MSD is displaying FE, a fatal error is present and must be cleared. See Section 9.3 for additional information.
RUN	OFF*	* If this is the first time you have powered the controller since installing the battery, the controller will be in Program mode and the LED will be OFF. Otherwise, the controller will be in either PROGRAM or RUN mode, depending on the state at power down.
Battery Good	ON	If a good battery has been installed and the Battery Switch has been set to ON, this LED will illuminate. If the LED is off, the battery is missing or bad or the battery switch is off. This LED must be ON in order to retain the User Program and related data when power is removed.

2.7 Setting the Controller IP Parameters

Using the Serial or USB Port

When connected to the serial or USB port, you can set the IP address and other IP parameters using PLC Workshop (V4.11 or greater) or IPSET, a standalone utility that you can download from the CTI web site.

Using the Ethernet Port

Firmware version 8.02 and above allows you to set the IP address and other IP parameters when connected to the Ethernet port. To enable this capability, SW11 must be set to the closed position. You can change the parameters using PLC Workshop (V4.11 or greater) or by accessing the 2500 controller embedded web server with your PC web browser.

2.8 Automatic IP Address Assignment

The 2500 controller is shipped from CTI with the IP parameters cleared. After you power up the controller, the IP address will be displayed as 0.0.0.0. When you connect the Ethernet port to a switch or PC, the controller will automatically generate a temporary IP address. You can connect to this address to set a permanent IP address. The address will be selected from a range of “Link-Local” addresses reserved for this purpose (169.254.1.0 to 169.254.254.255) with a subnet mask of 255.255.0.0 (/16).

NOTE:

The link-local address range is automatically used by Microsoft Windows when an IP Address cannot be automatically obtained from the network DHCP server.

You can use Windows Control Panel to set your PC to a static address that is compatible with the selected address. A compatible address:

- Is within the Link-Local Range above,
- Is not the same as the PLC IP address (displayed on the MSD),
- Uses the same subnet mask (255.255.0.0)

Alternately, if your PC is using DHCP to obtain an IP address, you can automatically connect using the following method:

1. Connect an Ethernet cable from the PC to the 2500 controller Ethernet port.
2. Reboot the PC.

NOTE

Depending on the PC configuration, it may take several minutes before the PC stops attempting to contact a DHCP server and generates the link-local address. You can confirm when this is done by opening the Command Prompt box and typing IPCONFIG.

CHAPTER 3 USER PROGRAMMING

3.1 Overview

The CTI 2500 controller provides several methods for programming a control application.

- Relay Ladder Programming
- Special Function Programming
- Analog Loops
- Analog Alarms

An overview of these capabilities is provided below. Comprehensive information can be found in the CTI 2500 Programming Reference Manual.

3.2 Relay Ladder Programming

Relay Ladder Logic (RLL) is a graphical language similar to a relay diagram. It has traditionally been used for discrete control applications. The RLL language includes the following groups of instructions.

Electro-Mechanical Replacements

These instructions include contacts, coils, timers, counters, and drums (stepper switches).

Bit Manipulation

These instructions provide the capability of reading, setting, and clearing bits as well as performing logical AND / OR operations.

BCD Conversions

The BCD instructions allow you to convert numbers between binary and binary coded decimal formats.

Word Move Instructions

Using word move instructions, you can copy bits of a word values from a source destination to a destination, which may be another memory type or another address within the same memory type. You can also copy selected bits between a word data type and a discrete Boolean data type.

Math

The math instructions allow you to perform traditional mathematical calculations, including addition, subtraction, multiplication, division and square root. You can also perform compare operations.

Table Instructions

The table instructions provide a means to manipulate array data. You can move data in and out of a table, perform table searches, and perform bit level comparisons between two tables.

Clock Instructions

The clock instructions allow you to compare the time and date as well as set the time and date in ladder.

Subroutine Instructions

The subroutine instructions allow you to create and call RLL subroutines. They also include the ability to call Special Function programs and subroutines.

Immediate I/O instructions

The immediate I/O instructions read or write to the physical I/O during RLL execution rather than waiting for the normal I/O update to take place later in the controller scan. See CHAPTER 6 for additional information regarding the scan timeline.

Miscellaneous

The RLL also contains instructions that allow you to turn on an output for a single scan (one shot), read diagnostic data from Profibus, and execute a PID loop.

3.3 Special Function Programs and Subroutines

Special Function (SF) programs and subroutines provide a statement-oriented procedural programming language. Using the Special Function instructions, you can derive solutions that cannot be done in RLL or would require complex RLL programming.

SF programs can be called from an RLL program or from analog loop or alarm tasks. SF subroutines can be called from RLL, SF programs, or other SF subroutines. SF programs and SF subroutines use a common instruction set.

The number of Special Function programs and Special Function subroutines that can be programmed depends on the product model. See Section 1.20.

Special Function Program instructions include the following groups:

Data Conversion

These instructions provide the capability to scale values and to convert between BCD and binary format.

Math

Math instructions support both integer and real numbers. Operators include standard math functions (add, subtract, multiply, divide, exponentiation, comparison, and bit operations) as well as a unique LEAD/LAG function that can be used with cyclic applications.

Program Flow

These instructions alter the order in which instructions are executed. They include the ability to call subroutines, to branch to a label, and to implement conditional branching (If, Then, Else).

Data Manipulation

These instructions provide the ability to search tables, pack and unpack data, and to perform various shift register operations.

3.4 Analog Loops

The analog loop function supports both velocity and position PID (proportional, integral, derivative) algorithms. Analog loops are used to control analog processes by varying the loop output so that the output of the process (Process Variable) matches a target value (Setpoint).

The operation of a particular loop is established by parameters entered by the user. In addition to executing the control loop, the loop task also provides the same alarm monitoring capability as the Analog Alarm task described in the next section.

The Setpoint can also be automatically varied using a Ramp/Soak Table. The Ramp/Soak Table allows you to program a change in the setpoint over time (Ramp) and followed by a period that the setpoint will remain the same (Soak). Using a series of ramp/soak steps, you can control most batch processes.

Loops are typically executed on a cyclic basis, independent of the user RLL or SF program logic. Some models of the CTI 2500 also support the capability of calling a PID loop from the RLL.

Loops may be cascaded, where the output of one loop becomes the input for the next loop. A loop may call a Special Function program to perform additional calculations. The number of loops supported is model dependent. See Section 1.20.

3.5 Analog Alarms

Analog Alarms are parameter-driven functions that allow you to monitor the Process Variable (PV). Each alarm block allows you to configure up to four absolute-value alarms and two sets of alarms that monitor the deviation of PV from the Setpoint. In addition, you can monitor the rate-of change of the Process Variable and detect a broken transmitter. An analog alarm may call a special function program to perform additional calculations. The number of analog alarm functions supported is model dependent. See Section 1.20.

CHAPTER 4 I/O SUPPORT

4.1 I/O Concepts

The following sections provide an overview of how the CTI 2500 controller stores input/output (I/O) data and updates the physical I/O modules.

4.1.1 I/O register

The CTI 2500 controller contains two I/O registers, which are memory areas used to hold I/O values. The *discrete* I/O register contains Boolean values (0 or 1). The *word* I/O register contains 16 bit word values. The size of the I/O register depends on the product model. See Section 1.20.

An I/O register address can be used as an input or an output. Discrete I/O register *inputs* are assigned a designator of X; discrete I/O register *outputs* are assigned a designator of Y. For example, an input associated with discrete I/O register address 6 would be designated as X6 and an output associated with discrete register address 10 would be designated as Y10.

Word I/O register *inputs* are assigned a designator of WX while word I/O register *outputs* are assigned a designator of WY. For example, an input associated with word I/O register address 16 would be designated as WX16 and an output associated with discrete register address 20 would be designated as WY20.

The I/O register *output* values represent the last value set by the user logic or by programming software. Unless changed by user logic or programming software, the I/O register *input* values represent the value last read from the physical I/O point associated with the I/O register address.

The I/O register locations are linked to the physical I/O modules by associating the register address with I/O points on a particular module to a range of I/O register addresses. For example, you could assign the 8 points of a discrete input module to X1-X8 or assign the outputs of analog output module to WY9 – WY17.

Assignment of I/O register locations to physical module I/O points, which is accomplished within the programming package, is referred to as an I/O configuration.

4.1.2 I/O Update

The physical I/O output points are updated with associated output values in the I/O register at the beginning of a new scan. At the same time, the I/O register input values are updated with values obtained from the associated physical I/O input points. See CHAPTER 6 for more detailed information.

Physical I/O also can be written or read during RLL execution by using immediate I/O instructions. See the CTI 2500 Programming Reference Manual for more information.

4.2 I/O Support

The CTI 2500 controller supports CTI 2500 Series 2500 I/O products, Siemens Series 505[®] and Siemens Series 500 I/O[®] products, and Profibus DP I/O products. CTI 2500 Series I/O modules and Siemens Series 505[®] I/O modules can be installed in the same rack as the CTI 2500 controller or installed in a remote base which is attached to the controller via a communications link. Series 500[®] I/O must be installed in a remote base.

4.2.1 CTI 2500 Series I/O

CTI provides a full range of I/O products including discrete input/output modules, analog input/output modules, serial and Ethernet communications modules, and specialty modules, such as vibration recording modules and warm backup modules. In addition, CTI provides remote base racks and remote base controllers. For a complete list of CTI products, log on to the CTI Web site (www.controltechnology.com).

4.2.2 Siemens SIMATIC 505[®] and Series 500[®] I/O Support

The CTI 2500 controller supports most current SIMATIC Series 505[®] discrete and analog I/O modules. In addition, the controller will also interoperate with designated non-CTI Special Function modules. See the CTI Web Site for a list of supported Siemens Series 505 products.

The controller will communicate with the following Siemens SIMATIC[®] remote base controllers:

- 505-6851 and 505-6851A (RS-485)
- 505-6850 and 505-6850A (Coax)

When using SIMATIC 505-6850 or 505-6850A remote base controllers, you must attach the RBC to the CTI 2500 using a Siemens SIMATIC 505-6860 I/O Channel Converter.

The CTI 2500 controller supports designated Siemens Series 500[®] discrete, analog I/O modules, and Special Function modules. See the CTI Web Site for a list of supported Series 500[®] Products.

The CTI controller will communicate with Siemens Series 500[®] I/O installed in a remote base using the following Remote Base Controllers:

- 500-5114 and 500-5114A (RS-485)
- 500-2114 and 500-2114A (Coaxial)

When using a 500-2114 or 500-2114A, you must attach the RBC to the CTI 2500 controller using a Siemens 505-6860 I/O Channel Converter.

4.2.3 Connecting to Remote I/O

Remote I/O is connected to the CTI 2500 controller via RS-485 cable. Cabling is typically connected in a trunk line/ drop line arrangement as shown below.

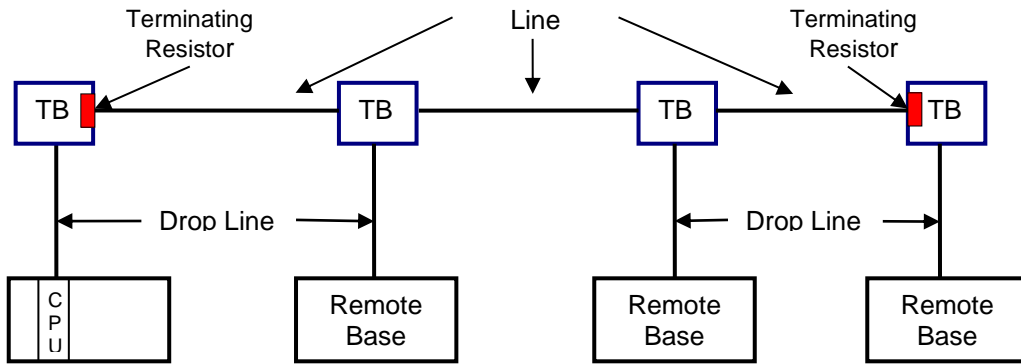

TB = Terminal Block

Cable Selection

The following cables (or equivalent) are acceptable for use for remote I/O connections.

Belden Cable Type	Outside Diameter	Impedance	Capacitance	Velocity	Center Conductor
9182	0.35 in. 8.9 mm	150 ohm	28.9 pf/m	0.78c	22 AWG 19x34 46 ohm/km
9271	0.24 in. 6.1 mm	124 ohms	40 pf/m	0.66c	25 AWG 7x33 104.3 ohm/km
9860	0.44 in. 11.2.mm	124 ohms	35.8 pf/m	0.78c	16 AWG Solid 13.8.ohm/km

Belden 9182 is suitable for intermediate length trunk lines. This cable cannot be intermixed with other cables for trunk lines. In addition, if this cable is used for a trunk line, it must also be used for all drop lines. It may also be used for drop lines with Belden 9860 or Belden 9271 trunk lines.

Belden 9271, which is smaller and more flexible, is suitable for use as drop lines as well as short trunk lines. For trunk lines, this cable may be intermixed with Belden 9860.

Belden 9860 cable, which provides low attenuation and distortion, should be used for long trunk lines.

When wiring the cable connectors, refer to APPENDIX F. – PRODUCT SPECIFICATIONS for the port pinout.

Cable Length and Termination

For each cable type, there is a maximum cable length. As the figure below indicates, the maximum cable length is measured from the CPU to the most distant tap. Note that a terminating resistor **must** be installed on the end terminal blocks.

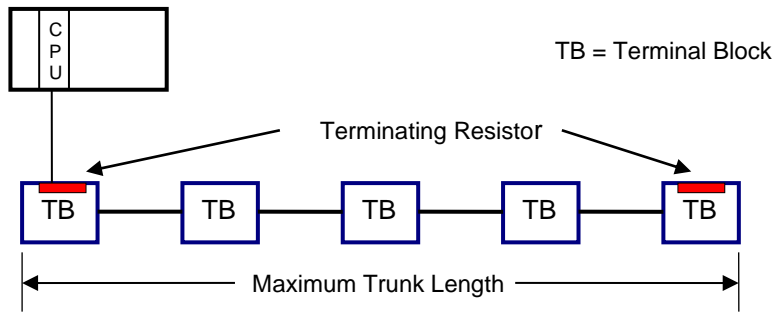

The maximum trunk length can be doubled by using a “T” topology as show below. Note the location of the terminating resistors.

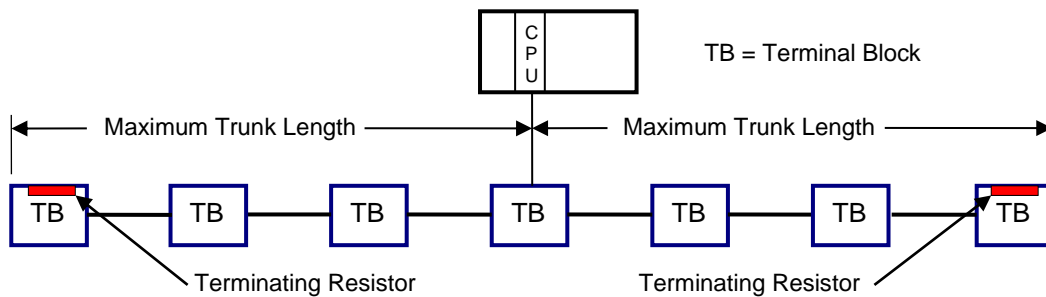

The following table designates the maximum trunk lengths for each cable type.

Number of Terminal Blocks	Maximum Distance		
	Belden 9182	Belden 9271	Belden 9860
2 - 5	2200 ft (670 m)	1100 ft (335 m)	3300 ft (1006 m)
6	2133 ft (650 m)	1067 ft (325 m)	3200 ft (975 m)
7	2067 ft (630 m)	1033 ft (315 m)	3100 ft (945 m)
8	2000 ft (610 m)	1000 ft (305 m)	3000 ft (914 m)
9	1933 ft (589 m)	967 ft (295 m)	2900 ft (884 m)
10	1827 ft (569 m)	933 ft (284 m)	2800 ft (853 m)
11	1800 ft (548 m)	900 ft (274 m)	2700 ft (823 m)
12	1733 ft (528 m)	867 ft (264 m)	2600 ft (792 m)
13	1677 ft (508 m)	833 ft (254 m)	2500 ft (762 m)
14	1600 ft (488 m)	800 ft (244 m)	2400 ft (732 m)
15	1533 ft (476 m)	767 ft (234 m)	2300 ft (701 m)
16	1400 ft (427 m)	733 ft (223 m)	2200 ft (671 m)

Other Topology Considerations

When multiple connections are required in close proximity, you should connect the equipment to a single terminal block instead of dedicating a terminal block to each connection. See the figure below for connection options.

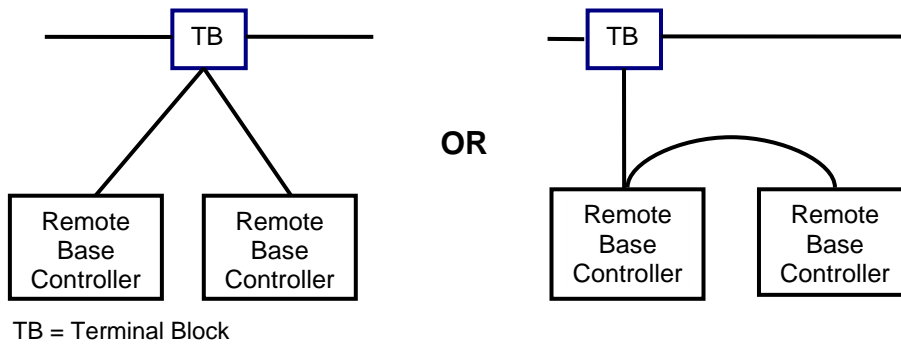

Terminal Block connections to the trunk line should be spaced so that the total length of the trunk line separating the taps is greater than the sum of the drop line lengths at the taps. In the illustration below, L1 should be greater than the sum of L2 + L3.

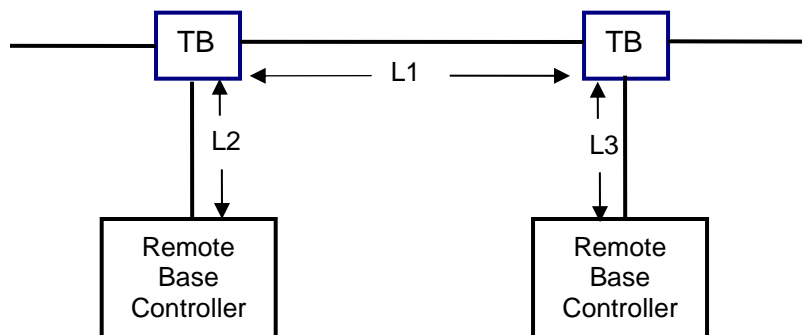

Termination Resistors

Termination resistors must be installed at the ends of the trunk line. The resistor value required depends on the trunk cable as specified in the table below

Cable Type	Resistor Value
Belden 9182	150 ohms, 5%, ¼ W
Belden® 9860 or 9271	120 ohms, 5%, ¼ W

4.3 Dual RBC Support

Firmware version 6.17 and above includes support for dual Remote Base Controller (RBC) configurations using an RS-485 network. Coaxial dual media cabling is not supported.

A dual RBC configuration consists of two remote base controllers installed in a special base (CTI 2500-R11-A or Siemens 505-6511). These bases also support the installation of dual power supplies, providing redundant sources of power

The dual RBC configuration provides redundant control of the I/O base. When power is applied to the base (and two RBCs are installed and operational), the RBC in the rightmost controller slot assumes the role of the active RBC, reading and writing the base I/O. The other RBC

assumes the standby role, responding to status requests from the 2500 Series controller, but not accessing the base I/O.

When a dual RBC configuration is detected, the 2500 Series controller continuously monitors the status of both RBCs. If a problem is detected with the standby RBC, the 2500 Series controller will disable it. Should the controller detect a problem with the active RBC while the standby RBC is operational, it will direct the standby RBC to assume the role of active RBC and disable the previously active RBC.

The standby RBC, if operational, also monitors the condition of the active RBC. If the standby RBC detects a problem with the active RBC it will automatically assume the role of the active RBC and will disable the previously active RBC. RBC status is reported in STW168.

An RBC that has been disabled can be re-enabled by temporarily changing the address switch to a different address then changing it back to the original address. Alternately, the RBC can be re-enabled by cycling power to the base.

Using your programming software, you can manually direct the RBCs to swap roles (if the standby RBC is operational). This capability is especially useful when executing diagnostic routines on an RBC, since diagnostic routines are always run on the standby RBC in dual RBC configurations.

RS-485 cabling to the dual remote base controllers must comply with the cabling and topology standards described in section 4.2.3. See *Other Topology Considerations* within this section for typical dual RBC connections.

NOTE:

*You can use either a CTI 2500-RIO-A (firmware version 7.03 or higher) or a Siemens 505-6851-B remote base controllers in a dual RBC configuration; however, you **cannot** intermix CTI and Siemens RBCs in the same base.*

4.4 Profibus DP I/O

The CTI 2500 Controller supports I/O devices that comply with the Profibus DPV1 standard. The following Remote Base Controllers can be used to allow CTI 2500 modules or Siemens SIMATIC Series 505® modules to be used on the Profibus network:

- CTI 2500-RBC Profibus Remote Base Controller
- Siemens SIMATIC® 505-6870 Profibus Remote Base controller.

The CTI 2500 controller can communicate with up to 112 Profibus slave devices, reading and writing up to 244 bytes per slave. The controller supports modular slaves with up to 128 slots (firmware version 6.07 and above). Profibus network data rates up to 12Mb are supported.

NOTE:

*The actual amount of data that can be exchanged with a slave is dependent on the capability of the slave.
The total amount of data that can be exchanged is limited by the I/O capability of the controller model.
Network data rates may be limited by the network configuration.*

4.4.1 Connecting the Profibus Network

Cable Selection

The Profibus network attaches to the Profibus DP connector on the front panel of the CTI 2500 controller using shielded twisted pair cable. The following table specifies the characteristics of the cable.

Characteristic	Requirement
Impedance	135 – 165 ohm (3 – 20Mhz)
Capacitance	< 30pF/m
Resistance	<110 Ω/km
Conductor Area	0.34mm ² (22 AWG)
Cable Diameter	0.34 mm

The following cables meet the Profibus DP cable specifications:

- Belden 3079A
- Belden 3079E (Hi-Flex)

The cable incorporates two color coded wires (red and green) surrounded by a shield. One wire is used for Transmit/Receive+ (TX/RX +) and the other for Transmit/Receive (TX/RX -). The color used to connect to TX/RX+ is arbitrary; however, the same color must be used throughout the system. Do not cross the TX/RX + and TX/RX – signals.

Profibus Connector

A special DB 9 connector is recommended for all Profibus DP installations.



Connector such as the one pictured above, provide either snap-in or screw terminal termination, horizontal cable connection, and switchable termination. Connectors such as these are commonly available from your distributor or other industrial suppliers.

Profibus Topology

Profibus slave devices are connected in a “daisy chain” arrangement as indicated in the following illustration.

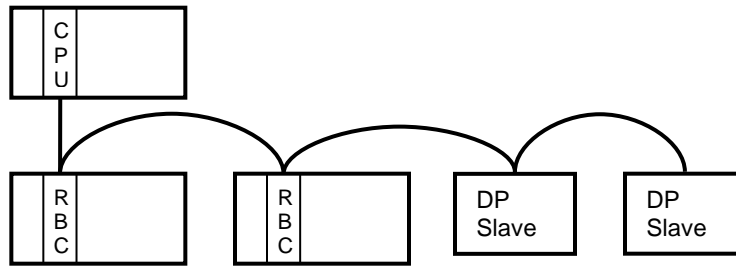

Up to 32 devices can be connected on a single segment. To increase distance or the number of devices supported, segments can be interconnected by using repeaters. Up to 10 segments may be connected together.

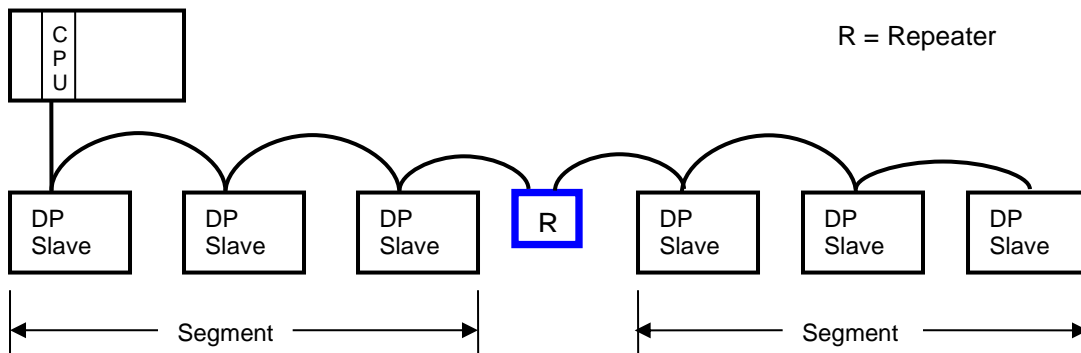

Cable Distance

Cable distance depends upon the baud rate being used. See the following table.

Baud Rate	Segment Distance	Total Distance (All Segments)
9.6 – 93.75 Kb	1,200 m (3,930 ft)	12,000 m (39,300 ft)
187.5 Kb	1,000 m (3,280 ft)	10,000 m (32,800 ft)
500 Kb	400 m (1,310 ft)	4,000 m (13,100 ft)
1.5 Mb	200 m (660 ft)	2,000 m (6,600 ft)
3 to 12 Mb *	100 m (330 ft)	1,000 m (3,300 ft)

* Baud rates greater than 1.5 Mb require special connectors and repeaters.

4.4.2 Configuring a Profibus Network

You may configure the Profibus network using either PLC Workshop or Siemens Com Profibus. The 2500 controller supports up to 112 slaves and a maximum of 64 module slots per slave.

PLC Workshop

The Profibus configuration tool is integrated into PLC Workshop V 4.52 and above.

1. Select the PLC Utilities/PLC Configuration menu item.
2. Click on the Profibus I/O button to open the Profibus configuration window.
3. Configure the Profibus network and assign slave I/O points to I/O register addresses.

COM Profibus

Configuring the Profibus network is a multi-step process.

1. Configure the Profibus network using the COM PROFIBUS software.
2. Export the configuration as a .2bf file.
3. Merge the resulting .2bf file from the Profibus configuration into your programming software.
4. Using the programming software, assign the slave I/O points to I/O register addresses.

For additional information regarding Profibus configuration, see the help documentation for PLC Workshop and Com Profibus.

4.4.3 Profibus Operation

Operational Mode

Using your programming software you may place the Profibus interface in Stop Mode or in Operate mode.

- In Stop Mode, the Profibus interface is not attempting to communicate with slave devices on the network. No I/O is being updated.
- When placed in Operate mode, the Profibus interface will attempt to configure and parameterize the I/O slave devices specified in the Profibus configuration. Assuming the attempt is successful, the Profibus interface will begin writing outputs and reading inputs from the slave devices.

When transitioning between modes, the Profibus interface is temporarily placed in Clear mode. In Clear mode outputs may be cleared (set to a value of off or 0) or not updated. The action taken depends on Fail-Safe flag in the GSD file for the device and the version of the Profibus configuration tool used.

If the Fail-Safe flag in the GSD file is set to 0, the outputs will be cleared. If the configuration tool supports only DPV0 (Siemens COM-PROFIBUS[®]), the outputs will be cleared, regardless of the flag setting. In either case, this may cause a bump in the I/O when transitioning between modes.

If the Fail-Safe flag is set to 1 and the configuration tool supports DPV1 (PLC Workshop V4.52 and above), the outputs will not be cleared. The status of the slave output will remain the same or transition to a state defined by the slave device parameterization.

Synchronization Mode

The synchronization mode determines how the Profibus network scan is synchronized with the 2500 Series controller scan. The Profibus synchronization mode can be set to Asynchronous or Synchronous.

- In Asynchronous mode, the controller scan is not synchronized the Profibus network scan. The controller can write outputs to and read inputs from the Profibus I/O buffer at any point in the Profibus scan.
- In Synchronous mode, the controller will wait until all outputs from the previous controller scan have been written to the slave devices before updating the Profibus interface with outputs from the current scan.

As long as the Profibus scan is at least 2 times faster than the controller scan, you should select Asynchronous mode to achieve maximum performance. For example, if the controller scan time is 30ms, the Profibus scan should be 15ms or less.

If the Profibus scan is less than 2 times faster than the controller scan, it is possible that a single scan transition of an output could be missed. In this case, you should set the scan mode to Synchronous or employ programming techniques to ensure that all outputs remain on for more than one scan.

Diagnostic Information

When a slave device encounters an alarm or error condition, it transmits a diagnostic message back to the Profibus interface. The diagnostic information can be retrieved by the 2500 controller user logic and saved in V memory table by using the RLL Read Slave Diagnostic (RSD) instruction. The saved information can then be processed in user logic or read by HMI workstations. See the *CTI 2500 Programming Reference Manual* for details regarding the RSD instruction.

It is always a good practice to retrieve and monitor the slave diagnostic data. It can provide a significant benefit in troubleshooting Profibus network problems if they should occur.

Profibus Alarms

The 2500 Series controllers do not support Profibus Alarms.

CHAPTER 5 CONTROLLER MEMORY

5.1 Overview

The CTI 2500 controller contains several different types of memory, each with a specific purpose. The memory types are described in the following sections.

5.2 User Program RAM

The User Program and related data is stored in battery-backed memory. As long as battery power is present, the contents of battery-backed memory will be maintained over a power cycle. The size of the battery backed memory is model dependent. See Section 1.20.

The battery-backed memory contains the following data:

5.2.1 User Program Elements

The following User Program elements are stored in battery-backed memory

- Relay Ladder Logic (RLL) Program
- Special Function Programs
- Special Function Subroutines
- Loop Parameters
- Analog Alarm Parameters
- Variable Data – 16 bit words
- Constant Data – 16 bit words
- Timer Counter Data
- Drum Data
- Shift Register Data
- Table Move Data
- One Shot Instruction Data

The amount of memory allocated to the User Program elements may be specified by the user. See the *CTI 2500 Programming Reference Manual*.

5.2.2 I/O register

The I/O registers contain the I/O data. I/O data includes input data obtained from the physical I/O modules and output values calculated by the user logic. See CHAPTER 4 for additional information. The I/O register memory allocation is fixed for each controller model.

5.2.3 Control Relays

Control Relays are used for internal storage of discrete (Boolean) data. Control Relays are not associated with the physical I/O. The number of control relays supported varies with the controller model. See Section 1.20.

Control Relays may be retentive or non-retentive. Retentive relays hold their value over a power cycle, as long as the battery is good. The address of the control relay determines whether it is non-retentive or retentive. See the table below.

Non- Retentive	Retentive
C1 – C768	C769 – C1024
C1025 – C1792	C1793 – C2048
C2049 – C2816	C2817 – C3072
C3073 – C3840	C3841 – C4096
C4097 – C4864	C4865 – C5120
C5121 – C5888	C5889 – C6144
C6145 – C6912	C6913 – C7168
C7169 – C7936	C7937 – C10240
C10241 – C32768	
C32769 – C56320 <small>See Note 1</small>	

NOTE 1: C400 Models using firmware Version 8.01 and above support these additional control relays. PLC Workshop users will require Workshop version 4.8 and above to utilize the additional control relays. APT users can use Jumper A to access the additional control relays. See Section 2.4. TISOFT programming software cannot access the additional control relays.

5.2.4 Status Words

Status Words are used to provide information about the controller operation. Because Status Words can be read by user logic, they can be used to condition the operation of the controller. In addition, the Status Words can be accessed by programming or supervisory control software. See APPENDIX B. – SYSTEM STATUS WORDS for a description of the System Status Words.

5.2.5 Configuration Data

The following configuration data is maintained in the battery backed memory:

- **I/O Configuration**
The I/O configuration data includes the I/O Configuration, which associates the logical I/O addresses with the physical I/O points, and the base enable status.
- **Memory Configuration**
The memory configuration contains the user memory allocation for each of the User Program elements listed in Section 5.2.1 above.
- **Profibus Configuration**
The Profibus configuration includes the Profibus parameter sets, which define the characteristics of the Profibus bus and slaves; the operational parameters, and the Profibus I/O configuration table.
- **Scan Configuration**
The scan configuration includes the scan type, the scan time, the task codes per scan, the scan watchdog value, and the analog scan time slice configuration. See CHAPTER 6 for a description of the CTI 2500 scan.

- **Password Data**

The password data includes the user password, the access level, and the enable status.

For additional details, refer to the CTI 2500 Programming Reference Manual.

5.3 *Flash Memory*

Non-volatile flash memory is used to store the operating firmware for the controller. The operating firmware can be updated in the field. See CHAPTER 10 for more information.

5.4 *High Speed DRAM*

Because the DRAM (Dynamic Random Access Memory) is significantly faster than either battery backed memory or flash memory, it is used to execute the operating firmware and the user program. The contents of the DRAM are lost when power is removed and must be refreshed from non-volatile storage during controller power up start.

CHAPTER 6 SCAN TIMELINE

6.1 Scan Overview

The controller executes most tasks in a cyclical sequential order. This order is referred to as the controller scan. There are two major divisions to the CTI 2500 controller scan; the discrete scan and the analog scan. The discrete scan contains elements commonly found in traditional programmable logic controllers. The analog scan provides an execution framework better suited to process control tasks such as PID loops and analog alarms.

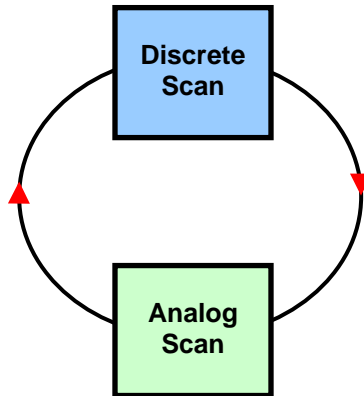
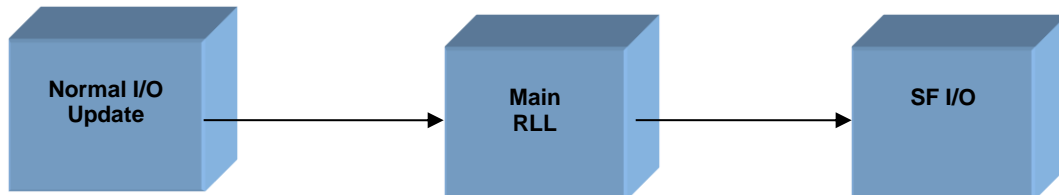

Figure 1. Controller Scan

6.1.1 Discrete Scan

The discrete scan consists of three tasks. These tasks always run to completion.



- **Normal I/O**
During the Normal I/O task, I/O register output values are transferred to the physical I/O and new input values are obtained from the physical I/O and written to the I/O register. All configured I/O points are fully updated each scan.
- **RLL Execution**
During the Main RLL Execution task, the Relay Ladder Logic is evaluated and executed. The I/O register is updated with values derived by the RLL. Physical I/O may be read or written during the RLL execution by using immediate I/O instructions.
- **Special Function I/O**

During the Special Function I/O tasks, requests from the Special Function modules installed in the local and remote bases and requests from remote base controller communications ports are serviced.

6.1.2 Analog Scan

The analog scan consists of tasks that may require multiple scans to complete. Included in this scan are the loops, alarms, and Special Function programs as well as communications and diagnostic functions.

Each task in the analog scan is allotted a time slice in which to run. Except for the diagnostic task, whose time slice is fixed, you can configure the time allocated to each task, allowing you to optimize the controller performance. See the CTI 2500 Programming Reference Manual for time slice configuration specifications.

Each task in the analog scan is executed in a predetermined sequence. The controller will advance to the next task when nothing is queued for task execution or the time slice expires. When the time slice expires, the task will be suspended and will resume execution in the next scan.

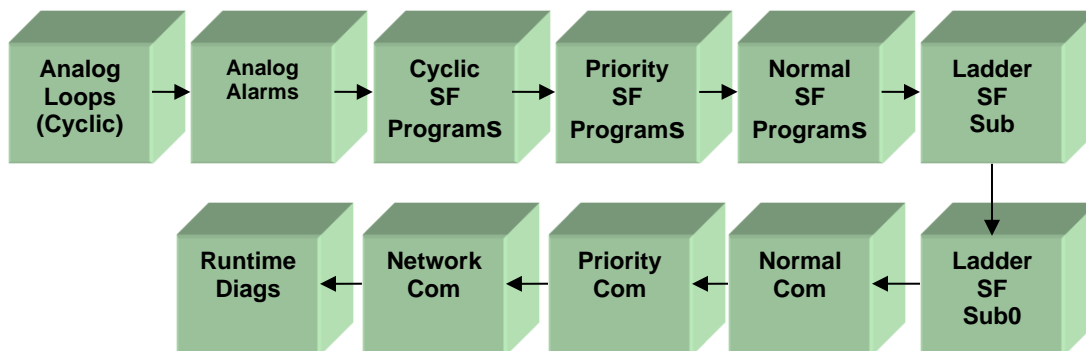

These analog tasks are further specified in the following sections.

Cyclic Analog Tasks

Cyclic tasks execute on a time interval basis, based on a user-specified sample rate. Cyclic tasks include Analog Loops, Analog Alarms, and Cyclic Special Function (SF) programs.

As illustrated in the figure above, loops, alarms, and cyclic SF program tasks are executed in separate time slices. Execution is prioritized based on how close an instance of the loop, alarm, or SF program is to overrunning (scheduled for another execution before the previous execution is finished). At the beginning of the time slice, the highest priority instance is executed first. Execution continues until the instance completes or the time slice expires. If it completes before the time slice expires, the next highest priority instance will be executed. If the time slice expires before an instance completes, the instance is suspended.

When there are no more instances to be executed or when the time slice expires, the controller begins executing the next analog task. If an instance has not completed executing before it is scheduled to execute again, an overrun flag will be set.

Special Function programs called by analog loops or alarms will be executed during the calling loop or alarm task time slice. Similarly, Special Function subroutines called by Special Function programs or other Special Function subroutines shall be executed during the calling program time slice.

Non-Cyclic Analog Tasks

Non-cyclic analog tasks are “called” from ladder, or are otherwise event based. They include:

- **Priority and Normal SF programs**
These programs are queued for execution when the SFPGM RLL box receives power flow. The processes are executed in the order in which they are queued. There is a separate task for priority SF programs and normal SF programs.
- **RLL Requested SF Subroutines**
These subroutines are queued for execution when SFSUB RLL box receives power flow. There is a separate task for SFSUB and SFSUB0 instructions requests.
- **Normal Communications**
This task processes deferred requests that require several scans to complete, such as program edit operations. These requests may originate from the local serial port, USB port, local Ethernet port, or from Special Function modules.
- **Priority Communications**
This task processes all requests from the serial and USB ports that can be processed in a single scan.
- **Network Communications**
This task processes all requests from the local Ethernet port, except deferred requests.
- **Run-time diagnostics**
Run-time diagnostics are executed continuously over several scans. The diagnostic task is allocated a fixed time slice.

NOTE

Ladder Initiated PID Loops and Special Function Programs and Subroutines that are marked for In-Line execution are executed immediately during the RLL portion of the Scan.

6.1.3 Cyclic RLL

The Cyclic RLL is executed on a user-specified interval. When queued for execution, it will interrupt any other task in the discrete scan or the analog scan. See the CTI 2500 Programming Reference Manual for additional information.

6.2 PLC Scan Types

The CTI 2500 controller provides three scan types: a fixed scan time, a variable scan time, and a variable scan time with upper limit.

6.2.1 Fixed Scan Time

When a fixed scan time is selected, the controller will attempt to start a new scan when the scan time interval specified by the user expires. All tasks in the discrete scan will be executed once. Then each task in the analog scan will be executed at least once.

If all analog tasks have been executed within the specified scan time, the controller will restart the analog scan, executing the analog tasks in order until the scan time expires. If a task is processing when it is time to start a new scan, it will be suspended.

If there is no work to be done, the PLC will idle until it is time to start another scan. If the total execution time of the discrete scan and the first execution of the analog scan exceeds the fixed time, the scan overrun flag will be set.

NOTE

To avoid scan overruns, you must set the fixed scan time greater to a value that allows all tasks to execute at least once.

6.2.2 Variable Scan

When variable scan is selected, the controller will execute all discrete and analog scan tasks once and then start a new scan. All discrete and analog tasks are guaranteed one execution per scan.

6.2.3 Variable with Upper Limit

When this option is selected, the controller shall execute the discrete scan once and then begin executing analog tasks. Each analog task will be guaranteed execution at least once during scan. The PLC will continue executing the analog scan tasks as long as there is work to be done or the upper time limit has been reached. When the upper time limit expires or no analog tasks require processing, a new scan shall begin. The scan overrun bit will be set in Status Word 1, if the total execution time for the discrete and analog scan exceeds the upper limit.

NOTE

To avoid scan overruns, you must set the upper limit time to a value that allows all tasks to execute at least once.

6.3 Scan Modes

Normally, the execution mode of the discrete scan and analog scan are locked together. Placing the controller in RUN mode, places the discrete scan and analog scan in run mode while placing the controller in PROGRAM mode places both scans in program mode.

For special application needs, it is possible to set the operating mode of the discrete scan and analog scan separately. The following sections describe the operating modes of each scan.

6.3.1 Discrete Scan Mode

The CTI 2500 supports the following discrete scan modes.

Mode	Description
PROGRAM	When the Discrete Scan is in PROGRAM mode, the RLL tasks do not execute. However, the NORMAL I/O and Special Function I/O tasks continue to operate normally.
RUN	When the PLC is in RUN mode, all discrete scan elements are executing.
EDIT	This sub-mode is automatically selected when you modify an RLL program while the controller is in RUN mode. While the controller is in EDIT mode, you can modify the RLL source while the non-modified RLL continues to execute. When you change to RUN mode after editing, the RLL will be recompiled. During this time, which can take several seconds, the I/O will be frozen at the last state. Should the compile fail, the controller will be placed in PROGRAM mode.

6.3.2 Analog Scan Mode

The Analog Scan Mode is called the Loop Processor mode by some programming software. You can select the following Analog Scan Modes:

Mode	Description
PROGRAM	When the Analog scan is placed in PROGRAM mode, the Loop, Alarm, and Special Function Program/Subroutine tasks do not execute. Nothing will be queued for execution. Other analog tasks, including communication tasks and the diagnostics task, continue to operate normally. THE ANALOG SCAN CANNOT BE PLACED IN PROGRAM MODE WHILE THE DISCRETE SCAN IS IN RUN MODE.
RUN	When the Analog Scan is in RUN mode, all analog tasks are running and enabled control blocks are queued for execution.
HALT	When the Analog Scan is placed in HALT mode, the Loop, Alarm and Special Function Program/Subroutine tasks will be suspended. However, the enabled control blocks will continue to be queued for execution. When the analog scan mode is changed from HALT to RUN mode, task execution will resume.

6.3.3 Scan Mode Locking

The Discrete and Analog scan modes are automatically locked when both scan modes are placed in PROGRAM mode. The scan modes are automatically unlocked when the analog scan is placed in RUN mode while the discrete scan is in PROGRAM mode. You can manually lock and unlock the scans when both scans are in RUN mode.

CHAPTER 7 COMMUNICATIONS

7.1 Overview

The CTI 2500 Controller provides several ways for programming software and HMI access the controller facilities.

7.2 Serial Communications

The CTI 2500 provides a serial port compatible with legacy programming interfaces. Alternately, Jumper B can be used to configure it as a printer port (see Section 2.4). The serial port supports baud rates up to 115.2KB. The baud rate of the serial port is set by switches on the controller circuit board (see Section 2.3). Other port parameters are fixed: Parity = Odd, Data Bits = 7, and Stop Bits = 1.

Depending on the position of the Electrical Interface switch (see section 2.3), the port will support RS-232 or RS-422. For most applications, you should select the RS-232 interface. This will allow you to use null modem cables or cables that you normally use to communicate with the Siemens SIMATIC® 505 controllers. If you need to run a cable for extended distances, you may choose the RS-422 electrical interface which provides better noise immunity. See APPENDIX F. – PRODUCT SPECIFICATIONS for the pinout of the serial port connector.

7.3 USB Communications

The USB port connector is identical to the port you find on peripheral devices such as printers. USB is often preferable to RS-232 because no user configuration or customl cables are required. You can connect your computer to this port using a USB cable that has a type B peripheral connector (sometimes called a USB printer cable). CTI USB driver software allows Windows programming software to communicate with the USB port as if it were a COM port. This driver can be obtained from the CTI web site.

WARNING

**The USB Port is for temporary connection only.
Do not use, connect, or disconnect unless area is known to be non-hazardous.
Connection or disconnection in an explosive atmosphere could result in an explosion.**

NOTE

TISOFT and APT, which are DOS applications, cannot access the USB programming port.

7.3.1 Installing the CTI USB Driver

Before you can use the USB port for programming, you must install the CTI-supplied driver on the PC. This driver provides an interface to the application program that emulates a standard COM port. Using this driver, Workshop can access the USB port in the same manner as the traditional serial port.

Obtaining the Driver Installation File

You may obtain the USB driver by downloading the driver installation file from the CTI web site (www.controltechnology.com). The driver file can be stored on a removable device or copied directly to the hard drive on the PC where the driver will be installed.

This driver is also included with Workshop programming software (V4.11 and above), available from FasTrak Softworks.

Extracting the installation files

The driver installation file is a zip file that contains all the programs and files needed to install the CTI USB driver. To extract the installation elements, click on the file to initiate the extraction process. When the extraction begins, you will be able to choose the folder that will contain the extracted files.

Installing the USB driver

See the “Installation Instructions” file included with the extracted files to display information on installing and configuring the driver.

7.3.2 Using the USB Driver

The USB driver is initiated when the CTI 2500 controller is connected to the USB port on your PC. When installed, the driver will default to the lowest-numbered serial port that has not been assigned (usually COM3). You can change the COM port number to a different value if needed. See the Installation Instructions file referenced above for instruction on doing this.

When using Workshop, you will be able to select the assigned COM port as a serial port connection in the “Fast PLC Setup” option under the File menu. Once the port is selected, you will be able to access the CTI 2500 controller by selecting the “Fast PLC Connect” option.

7.4 Ethernet Communications

The CTI 2500 controller provides a means to attach the controller to a plant network via an integrated 10/100Mb Ethernet port. The port automatically negotiates the Ethernet speed and duplex status.

7.4.1 Automatic IP Address Assignment

Starting with Firmware version 6.07, the 2500 Series controller will automatically assign an IP address to the local Ethernet port during power up start if no IP address is stored in flash or the stored IP address is 0.0.0.0. The controller is shipped from CTI in this state. It can also be placed in this state by resetting the IP parameters to the factory default (see Section 7.4.3) or by manually setting the IP address to 0.0.0.0. If you manually set the IP address to 0.0.0.0, the link local IP address will be assigned only after power a power up start.

Automatic IP Address assignment provides a temporary IP address and subnet mask, which can be used to access web based diagnostic information and to set a permanent IP address using Workshop or the controller web server.

The IP address will be selected from a reserved set of “link local” IP addresses, which can range from 169.254.1.0 to 169.254.254.255. The subnet mask will be set to 255.255.0.0. Because this set of IP addresses is non-routable, the default router will be set to 0.0.0.0.

Before using the IP address, the controller will attempt to determine whether another device on the network is using the randomly generated address. If a duplicate is detected, the controller will continue selecting addresses until no duplicate is found. Until an IP address is assigned, the MSD will display 0.0.0.0. Afterwards it will display the assigned address.

7.4.2 Assigning a Static IP Address

Before using the port for general network applications, such as programming or HMI access, you must assign a static IP address. The static IP address will be stored in flash and will continue to be used until changed.

To accomplish this, you can use PLC Workshop (Version 4.11 or greater), the embedded web server (firmware version 8.02 and above), or the CTI standalone utility program IPSET (serial or USB port only). You may obtain IPSET by downloading it from the CTI web site <http://www.controltechnology.com/downloads/>.

The IP address and related parameters must be compatible with the network you are using. Contact your network administrator if you have questions regarding the IP address. See Appendix C for additional information.

CAUTION

IP addresses must be unique, even between the local Ethernet port and an Ethernet module in the same base. Duplicating IP addresses can cause unpredictable problems, including loss of communications with the Ethernet port.

Setting the IP Parameters via the Serial or USB Port

You can use PLC Workshop or the IPSET utility to set the IP parameters when connected to the USB or serial ports.

Setting the IP Parameters using the Ethernet Port

Starting with firmware version 8.02, you can set the IP parameters via the Ethernet port using PLC Workshop or the embedded web server. By default, this capability is disabled, since inadvertent or malicious change of the IP parameters can disrupt the control process. However, you can enable this feature by setting SW11 to the closed position. See section 2.3. Because of the potential risk, CTI recommends that you set SW11 back to the Open position before placing the controller in a production environment.

7.4.3 Resetting IP Parameters to the Factory Default

The IP parameters can be cleared by moving Jumper D to the **CLOSED** position (see section 2.4) and powering up the controller. Once the IP address has been cleared, the Multi-Segment Display (MSD) will display 0.0.0.0 (if the Ethernet port is not connected to the network) or a Link Local address (if the port is connected). Once the IP address is cleared, you must move jumper D to the **Open** position and re-power the controller.

7.4.4 Duplicate IP Address Detection

The controller will attempt to determine if there is another device on the network with the same IP address as the one stored in flash in the following situations:

- The controller is powered up with a non-zero IP address,
- The IP address is changed to value other than zero,
- The Ethernet Link transitions from Unconnected to Connected.

If a duplicate address is detected, the Network Status (NS) LED color will change to red and the associated bit in STW244 will be set.

NOTE:

This is a warning only; the local port will continue to use the static IP address.

Because a duplicate IP address can disrupt communications with the local Ethernet port, you should determine the cause of the problem and correct it by one of the following:

- Detaching the offending device from the network,
- changing the IP address of the offending device, or
- Changing the IP address of the controller Ethernet port to one that is not a duplicate.

The controller may not detect a duplicate IP address in every case. For example, devices can be added to the network while the Ethernet link is connected and operating normally. Also, some older devices may not respond to a duplicate IP address probe message.

7.4.5 TCP Port Number Support

TCP/IP provides for multiple logical ports. Each “port” represents a particular service offered at the IP address. The CTI 2500 Controller supports the following logical ports:

Programming Port (TCP Port 4452)

The programming port is intended for use with network-capable programming software, such as PLC WorkShop. To use the programming port, connect to TCP port 4452. This port supports all programming, data access, and control requests. Only one client may be connected to the programming port at a time. The CTI 2500 gives priority to all requests to the port 4452. UDP is not supported.

When programming via local Ethernet port using TCP port 4452, you can prevent anyone else from concurrently modifying the program via another communications port or SF module by enabling **PORT LOCKOUT** using your programming software. When **PORT LOCKOUT** is enabled, requests to modify the user program originating from other physical ports or special function modules are rejected.

SW6 must be in the open position to prevent other users of the local Ethernet port from modifying the user program. See Section 2.3 for additional information.

Data Access Port (TCP Port 4450/1505)

To use the Data Access port, you should connect to TCP port 4450. To provide compatibility with installations using the CTI 2572 and 2572-A, you may also connect to the Data Access port using TCP port 1505. A total of three concurrent TCP connections to either port 4450 or port 1505 are allowed. For example, you could have two connections to port 4450 and one connection to port 1505. UDP is not supported.

The Data Access port is intended for use with HMI (Human Machine Interface) and SCADA (Supervisory Control and Data Access) software. Since the Data Access Port uses the same CAMP protocol used by CTI 2572 and 2572-A modules, drivers are available for most popular SCADA software packages.

Port 4450/1505 can also be used with network-capable programming software when you want to allow the user program to be displayed but not modified. By default, the Data Access port will reject commands that attempt to alter the User Program, returning a “port lockout” error.

Some legacy network programming interfaces, such as APTNET, support only Port 1505. If you need to use TCP Port 1505 as a full function programming port (allowing programs to be modified), you can set the Programming Port switch as described in Section 2.3.

Caution

When you choose to use Port 1505 as a full function programming port, there is no means to prevent two users from concurrently modifying the User Program, since more than one programming connection to the Ethernet port is allowed.

Web Server Port

The web server port allows a standard web browser to access the controller web pages. These pages provide information about the controller, diagnostic statistics regarding the operation of the product, and access to the event log. See Section 9.1.2 for a description of the event log.

To access the controller web pages, simply enter the IP address of the controller in the browser URL field.

CHAPTER 8 SYSTEM RESTART OPTIONS

8.1 Overview

The 2500 Series controller provides several software initiated restart options, which can be accessed via your programming software. The restart options offer a means to place the controller in a known state without cycling power. A system restart is required to clear a controller fatal error condition.

8.2 Restart Options

The following system restart options are available:

- Power-Up Restart
- Partial Restart
- Complete Restart

The primary difference in the restart options is the state of the controller after the restart procedure has completed.

The power-up restart procedure places the controller in the same state as cycling power to the PLC. The final state of the PLC depends on the state of the battery and the Program Source setting. This option is inhibited if the controller is in Run mode and the battery is bad or off.

The complete and partial restart procedures differ as follows:

- The complete restart places all loops in manual mode
- The complete restart clears all analog outputs
- The complete restart clears all retentive relays
- The complete restart restores the timer/counter/drum presets from ladder

See the following section for more information.

8.3 System Restart Table

The table below indicates the PLC state after completing the startup operations above. In the table below N/C designates no change in value.

System Restart Table

Item	Power-Up Restart			Partial Restart	Complete Restart	
	Battery					
	Off		On			
	Source= Flash ¹	Source = RAM				
RLL Mode (Run, Program, Edit)	RUN	Program	N/C	N/C ²	N/C ²	
Loop Mode	RUN	Program	N/C	N/C ²	N/C ²	
Individual Loop Mode	Obtain from User Program Flash	Cleared	N/C	N/C	Manual	
Discrete I/O (X,Y)	Cleared	Cleared	Cleared	Cleared	Cleared	
Word I/O (WX,WY)	Cleared	Cleared	N/C	N/C	Cleared	
Non-Retentive Control Relays	Cleared	Cleared	Cleared	Cleared	Cleared	
Retentive Control Relays	Cleared	Cleared	N/C	N/C	Cleared	
Forced Elements	Cleared	Cleared	N/C	N/C	N/C	
TMR/CNTR/Drum Presets	Restore from User Program Flash RLL	Cleared	N/C	N/C	Restore from ladder	
V Memory	Cleared	Cleared	N/C	N/C	N/C	
L,K,S Memory	Load From	Cleared	N/C	N/C	N/C	
Memory Configuration	User Program Flash	Default	N/C	N/C	N/C	
I/O Configuration		Cleared	N/C	N/C	N/C	
DP Configuration		Cleared	N/C	N/C	N/C	
DP I/O Mode		Stop	N/C	N/C	N/C	
DP Synch Mode		Asynch	N/C	N/C	N/C	
Scan Time / Type		Variable	N/C	N/C	N/C	
Task Codes /Scan		2	N/C	N/C	N/C	
Password Data		Cleared	N/C	N/C	N/C	
Time of Day		N/C	N/C	N/C	N/C	N/C
Scan Watchdog		1 sec	1 sec	N/C	N/C	N/C
Port Lockout	Unlocked	Unlocked	N/C	N/C	N/C	
Fatal Error	Cleared	Cleared	N/C	Cleared	Cleared	
1. Assumes flash contains a valid program. If not valid, the source is set to RAM (see RAM column).						
2. If controller was in Fatal Error, the controller will start in Program Mode.						

CHAPTER 9 TROUBLESHOOTING

This section provides information that you may find useful in diagnosing and correcting problems you may encounter with using the CTI 2500 Controller

9.1 Troubleshooting Aids

9.1.1 LED Indicators

The status LEDs and the Multi Segment Display (MSD) can be used to determine the type of failure.

- If the CPU Good LED is not illuminated and the MSD displays FE, a fatal error has occurred. You can use your programming software to display the cause of the fatal error. The system Event Log can also be used to detect the cause of a fatal error. See Section 9.3 below.
- If the CPU Good LED is not illuminated and the MSD displays an E followed by a two digit number, a startup error or a firmware update error has occurred. The two digit number provides the cause of the failure. See Section 9.2 below for startup errors. See Section 10.5 for firmware update errors.

9.1.2 Event Log and Diagnostic Statistics

The event log and diagnostics can be accessed by the controller web pages. You can access the web pages using a standard web browser by entering the controller IP address in the browser URL field.

The event log maintains a time stamped record of significant software events. All fatal and non-fatal errors result in an entry into the event log. Since the event log is stored in battery backed memory, it will be maintained over a power cycle as long as battery power is present.

The diagnostic statistic web pages provide a means to analyze the operation of various controller subsystems, such as the remote I/O or Ethernet port.

9.1.3 System Status Words

The controller maintains an array of words that provide the status of various module subsystems. The words may be accessed using your programming software or by the user program. See APPENDIX B. – SYSTEM STATUS WORDS.

9.2 Startup Errors

Startup errors prevent the application firmware from executing. They are typically the result of corrupted or missing application firmware. When a startup error occurs, the CPU Good LED will not be illuminated and the MSD will display an error code indicating the cause of the error.

Error Number	Description	Corrective Action
E01– E20	Indicates a problem initializing hardware or software.	Cycle power. If the problem persists contact CTI Product Support
E81 – E99	Missing or corrupted operating system firmware	These errors will occur if you remove power from the controller during a firmware update before the new firmware has been completely written to flash. To correct this problem, reload the operating system firmware. See CHAPTER 10 for instructions.

9.3 Fatal Errors

These errors are reported by run-time diagnostic or application firmware when an error is detected that could cause unreliable or erroneous operation.

When a Fatal Error occurs:

- The CPU Good LED will not be illuminated,
- The Multi-Segment Display (MSD) will alternately display “FE “ and the fatal error code (See section 9.3.2)
- User program execution will be halted,
- I/O update will be discontinued and Output Disable will be asserted,
- Serial, USB, and Ethernet port buffers will be cleared,
- Pending requests from SF modules and the local communications ports will be aborted.

The local serial, USB, and Ethernet ports will continue to function; however, the type of requests that will be serviced will be limited to those necessary to determine the cause of the fatal error and to correct it.

9.3.1 Clearing Fatal Errors

Most other fatal errors can be cleared by initiating a Partial Restart or a Complete Restart using your programming software. In the event that this does not clear the fatal error, you must disconnect line power, remove the battery, and then re-apply power.

NOTE:
Removing power and disconnecting the battery will clear the controller memory. The User Program and all related data will be erased, requiring you to reload the User Program.

After clearing the fatal error you should re-install the battery. Additional information regarding the error can be obtained from the event log.

9.3.2 Fatal Error Codes

This section describes the fatal errors that may be encountered and provides guidance for dealing with the error.

Code	Description	Correction
0102	System Reset: Unknown Cause A system reset that was not routed through the system exception handler occurred	Use Partial or Complete Restart to clear this error. This type of error usually indicates a flaw in the application firmware. Contact CTI support if this problem persists.
0103	Hardware Watchdog Timeout A system reset occurred when the hardware watchdog timer expired.	Use Partial or Complete Restart to clear this error. This type of error usually indicates a flaw in the application firmware. Contact CTI support if this problem persists.
010b	Abnormal Shutdown Indicates that power was lost before the controller could complete an orderly shutdown.	Use Partial or Complete Restart to clear this error.
010d	User Program Flash Restore Error Indicates that the program stored in flash could not be used.	After clearing this error, using Partial or Complete Restart, you must erase the User Program in flash, reload the program to RAM, then save it to flash.
0113	Scan Watchdog Timeout This error indicates that the actual scan time exceeded the watchdog setting.	<p>The most common cause of the problem is setting the cyclic RLL cycle too small, so that other scan elements do not get enough time to run. If errors persist, you may need to increase the value of the scan watchdog.</p> <p>This may also be caused by an in-line special function program (SFP) that takes too long to complete. Look for a continuous loop condition. If the loop condition is not present you will need to modify the SFP or use the PETWD instruction. See the <i>2500 Series Controller Programming Reference Manual</i> for more information.</p> <p>In some situations this could be caused by an excessive rate of broadcast frames received by the Ethernet port. If this is the case you should use an Ethernet switch capable of broadcast storm protection to limit the broadcast rate.</p>
0114	Compiled RLL Checksum Error Indicates the compiled RLL has been corrupted.	These errors may be caused by too excessive conductive or radiated interference affecting the controller memory.
0134	Compiled SF Checksum Error This error indicates that one or more compiled SF programs/subroutines have been corrupted.	Use Partial or Complete Restart to clear this error. If this problem persists, ensure the system is properly grounded.
0300	Operating System Error Indicates that an error has been detected in the operation of the system firmware.	<p>Error details can be obtained from the system event log.</p> <p>If this error persists, contact CTI Product Support.</p>

Code	Description	Correction
0400	Diagnostic Error Indicates that a general diagnostic error has occurred.	Error details can be obtained from the system event log.
0600	Hardware Failure Indicates that a failure in a hardware component has been detected.	Error details can be obtained from the system event log.
0608	System Clock Failure. Indicates the system clock cannot be accessed.	To clear this error you must cycle power to the controller. If the problem persists, contact CTI Product Support.
060b	L Memory Invalid: Power loss during in-progress RLL edit operation.	After clearing this error, you must reload the RLL.
060C	L Memory Invalid: Power loss during L memory resize operation	After clearing this error, you must reload the RLL.
060d	S Memory Invalid: Power loss during in-progress S memory edit operation.	After clearing this error, you must reload the RLL.
060F	System service failure.	To clear this error, you must cycle power to the controller. If the problem persists, contact CTI Product Support.
0611	RLL Source checksum error detected during power-up start. Indicates that the RLL is invalid and cannot be compiled.	After clearing the fatal error using Partial or Complete Restart, you must reload the RLL Program to prevent this error from re-occurring.
0612	S Memory checksum error detected during power-up start. Indicates the Special Function source is invalid and cannot be compiled.	After clearing the fatal error using Partial or Complete Restart, you must reload the User Program to prevent this error from re-occurring.
0615	Startup RLL compile failed Indicates the RLL failed to compile during a power-on start	Error details can be obtained from the system event log. After clearing the fatal error using Partial or Complete Restart, you will need to correct RLL errors before it will compile.
0616	Startup SFP/SFS compile failed Indicates at least one SFP or SFS failed to compile during a power-on start.	Error details can be obtained from the system event log. After clearing the fatal error using Partial or Complete Restart, you will need to correct the SFP or SFS error and re-enable the program or subroutine.
0618	I/O Interface Timeout Indicates the I/O interface failed to respond to a request from the main processor.	Clear the error using Partial or Complete Restart. If this error persists, contact CTI Product Support.
0620	Profibus I/O Error Indicates that the Profibus interface experienced a fatal error.	Error details can be obtained from the system event log. Clear the error using Partial or Complete restart. If the action above does not clear the error, remove the battery and cycle power. If the error persists, contact CTI Product Support.
0700	Control block data is invalid	These errors indicate that memory has been corrupted or that a problem exists in the OS firmware.
0701	Expression evaluation failed due to corrupt or invalid expression	
0702	SF Execution failed--Program	

Code	Description	Correction
	evaluation data is invalid	After clearing the error using Partial or Complete Restart, try reloading the program. If the error persists, contact CTI Product Support.
0703	Expression evaluation failed due to corrupt or invalid parameter	
0704	SF number from RLL is invalid	

9.4 Non-Fatal Errors

Non-fatal errors are errors that may affect the control system but do not prevent the controller for operating reliably. Non-fatal errors can be displayed using the programming software and by examining designated Status Words.

The following table lists the system non-fatal errors that may occur and how to resolve them.

Error	Cause	Correction
Scan Overrun (STW 1:14)	The designated fixed scan time or upper limit is not sufficient to execute the User Program.	Increase the fixed scan time or upper limit. Reduce the analog scan time slices. Reduce the number of task codes per scan
I/O Base Failure	A remote base controller is not responding.	Ensure that the base is connected to the I/O network and that the cable is not defective. Ensure that you have not duplicated a base address. Replace the remote base controller.
I/O Module Failure (STW 1:12)	An I/O module is reporting a failure	Use your programming software to determine which module has failed. Replace the module.
Too Many SF Modules Installed (STW 1:10)	More than 16 Special Function Modules have been installed.	SF modules beyond 16 will not be accessed. Remove excess SF modules.
I/O Mismatch	The actual base configuration does not match the I/O configuration in the User Program.	Use STW 11- STW 26 to determine which slots are mismatched. Change the I/O configuration to match the actual configuration. Change the actual configuration to match the I/O configuration.
SF Module Failure (STW 1:12)	A Special Function module is not communicating properly with the controller	Determine which module is failing using your programming software and replace the module.
Password Disabled (STW 1:5)	A password exists but has been disabled.	This is only a warning.
TOD Clock Failure (STW 1:8)	Indicates that the time of day clock is not operating properly.	This is typically a hardware failure. If you are using the TOD clock for control, you will need to replace the controller.
Battery Bad/Low (STW 1:15)	Indicates that the battery is not operational or that it may soon fail.	Ensure that the battery switch is on. Replace the battery.
RLL Program Error (STW1:6)	Indicates a general program error	See STW 200 for the error code
RLL Subroutine Stack Overflow (STW 1:7)	Indicates a stack overflow has occurred.	Determine the number of the subroutine that caused the error by examining STW 163 and correct the programming error.
Previous RLL Instruction failed (STW1:11)	Indicates that the previous RLL instruction failed to execute properly due to a run time parameter error.	See Status Word 200 for more specific information and correct the programming error.

Error	Cause	Correction
RLL Source Checksum Error (STW 1:16)	The RLL Source is invalid	Reload the Ladder program
Loops are Overrunning (STW162:3)	Indicates that insufficient time is allocated to process enabled loops at the designated sample rates.	See the Loop V flag and the LPET variable to determine which loops are overrunning. Increase the loop sample time or increase the loop time slice.
Alarms are overrunning (STW 162:4)	Indicates insufficient time is allocated to process enabled alarms at the designated sample rates	See the Alarm V flag and the APET variable to determine which alarms are overrunning. Increase the alarm sample time or increase the alarm time slice.
Cyclic SF Programs are overrunning (STW 162:5)	Indicates insufficient time is allocated to process cyclic SF programs at the designated cycle rates	See the PPET variable to determine which loops are overrunning. Increase the Cyclic SF time or increase the Cyclic SF time slice.
Normal SF Queue is full (STW 162:6)	Indicates that that you are requesting Normal SF execution faster than they can be executed.	Increase the Normal SF time slice.
Priority SF Queue is full (STW 162:7)	Indicates that that you are requesting Priority SF execution faster than they can be executed.	Increase the Priority SF time slice.
Cyclic SF Queue is full. (STW 162:8)	Indicates that that you are requesting Priority SF execution faster than they can be executed.	
Error occurred during loop calculation (STW 162:9)	Indicates that an SFP called from a loop causes a loop parameter to be set to an invalid value.	Correct the Special Function Program
Error occurred during alarm calculation (STW 162:10)	Indicates that an SFP called from an alarm causes an alarm parameter to be set to an invalid value.	Correct the Special Function Program
A Control Block is disabled (STW 162:11)	Reported when any loop, alarm or scheduled SFP or SFS is disabled.	Information only. Determine if a Control Block is disabled in error.
Attempt to execute an undefined SFP from RLL (STW 162:12)	Reported when RLL attempts to call a Special Function Program that has not been created.	Correct RLL instruction or create a new SFP.
Attempt to execute a restricted SFP from RLL (STW 162:13)	Reported when RLL attempts to call a restricted SF program.	Correct the RLL instruction or change the classification of the SF program.
RLL Subroutine nesting level exceeded (STW 200, error 4)	Indicates more than 32 subroutines are nested.	Correct the RLL
Table Overflow (STW 200, error 5)	This error is reported when the RLL instruction attempts to access an invalid memory location via a programmable index.	STW 1:11 will be set. Correct RLL Typically occurs with MOVE or LDA instructions.

Error	Cause	Correction
Attempt to call a non-existent subroutine (STW 200, error 6)	This error is reported when the RLL attempts to call an in-line subroutine that has not been created	Correct RLL or Create New subroutine
SFP has not been compiled (STW 200, error 8)	Reported when the RLL attempts to call an in-line Special Function Program that is not compiled.	Correct RLL or the Special Function Program
SFP is currently disabled (STW 200 error 9)	Reported when the RLL attempts to call an in-line Special Function Program that is disabled	Attempt to enable the Special Function Program. If fails to compile, correct problem(s) and re-enable.
SFP Type is not Normal or Priority (STW 200, error 10)	Reported when the RLL attempts to call an in-line SFP that is a restricted or cyclic type.	Correct the RLL or the SFP type
S Memory is Busy (STW 200, error 11)	Reported when the RLL attempts to call an in-line SFP or SFS while an edit operation is taking place.	This is a temporary error. Execution will resume after the edit.
PID instruction references a loop that is not configured (STW 200, error 13)	Occurs when the PID instruction calls a loop than has not been configured.	Correct the RLL or Create a new Analog Loop.
PID instruction references a loop that is not enabled (STW 200, error 14)	Occurs when the PID instruction calls a loop than has not been enabled.	Correct the RLL or Create a new Analog Loop.

CHAPTER 10 UPDATING FIRMWARE

10.1 Overview

The CTI 2500 controller stores the operating firmware in non-volatile flash memory. You can replace the operating firmware with a newer version to correct problems or add new features. During this procedure, the new firmware will be copied to controller RAM, verified, and then written to flash memory.

CAUTION

After the firmware update procedure is completed successfully, any User Program stored in the controller will be cleared. If you do not have a backup copy, you should save the program before starting the firmware update process.

There are two methods available for updating firmware:

- **Serial Port Method**
You can use either the USB port or the RS-232 port to update the firmware. CTI recommends using the USB port, if possible. This port has a much faster data rate than the serial port, significantly reducing the time to copy the update file to the controller.
- **SD Card Method (Firmware Version 5.0 and above)**
You can update the firmware using an SD card containing the firmware update file. See APPENDIX G. – SD CARD REQUIREMENTS.

10.2 Serial Port Method

10.2.1 Firmware Update Planning (Serial Port Method)

In order to upgrade the controller firmware you will need the following:

- **A PC (desktop or laptop) with a RS-232 serial port or USB serial port**
If you are using the USB port, you must have previously installed the CTI USB driver. See Section 7.3 for additional details.
- **A copy of the HyperTerminal Program**
HyperTerminal is included with Windows XP but not Vista or Windows 7. However, you can find a downloadable version of HyperTerminal that is free for personal use on the Internet.
- **A null modem cable (for RS-232) or a USB cable**
See Section 7.2 for cable requirements. This is the same cable used to connect the CTI 2500 controller serial port to your PC programming software.
- **A copy of the firmware upgrade file**
The firmware update file can be obtained from the CTI Web site.
- **A base and power supply compatible with the CTI 2500 processor**
The controller must be installed in the base and powered during the firmware upgrade process.
- **The CTI 2500 controller to be upgraded**

10.2.2 Firmware Update Procedure

The following procedure is used to update the firmware on the CTI 2500 controller:

1. If the controller is installed in a base, disconnect power from the base and remove the controller from the base.
2. Set the firmware update switch to the Firmware Update position (see Section 2.3).
3. If you are using the RS-232 serial connection, you can set the serial port baud rate using the baud rate switches. CTI recommends using the highest available baud rate to minimize the download time. If you are using the USB port (highly recommended), the data rate is set automatically.
4. Install the unit into the base and apply power. The controller should display U01 on the multi-segment display, indicating it is waiting for you to transfer the firmware update file to the controller.
5. Connect the serial cable or USB cable to the PC and to the controller.
6. Start HyperTerminal, a standard Windows® accessory utility (or other data communications program). The following steps deal specifically with HyperTerminal setup.
 - a. Select COM port under 'File'/'Properties'. If the USB Driver has been installed, the assigned COM port will be shown in the selection menu. After selection, click on the OK button.
 - b. If you are using a serial port, press 'Configure' to set the communications parameters. The baud rate should be set to match the controller baud rate. Other parameters should be set as follows: Data Bits = 8, Parity = None:, Stop Bits = 1, Flow Control = None
 - c. Then press 'OK' to return to main window.

7. Go to the “Transfer/Send File” menu to select the firmware upgrade file and the “Zmodem” protocol. See the following example.

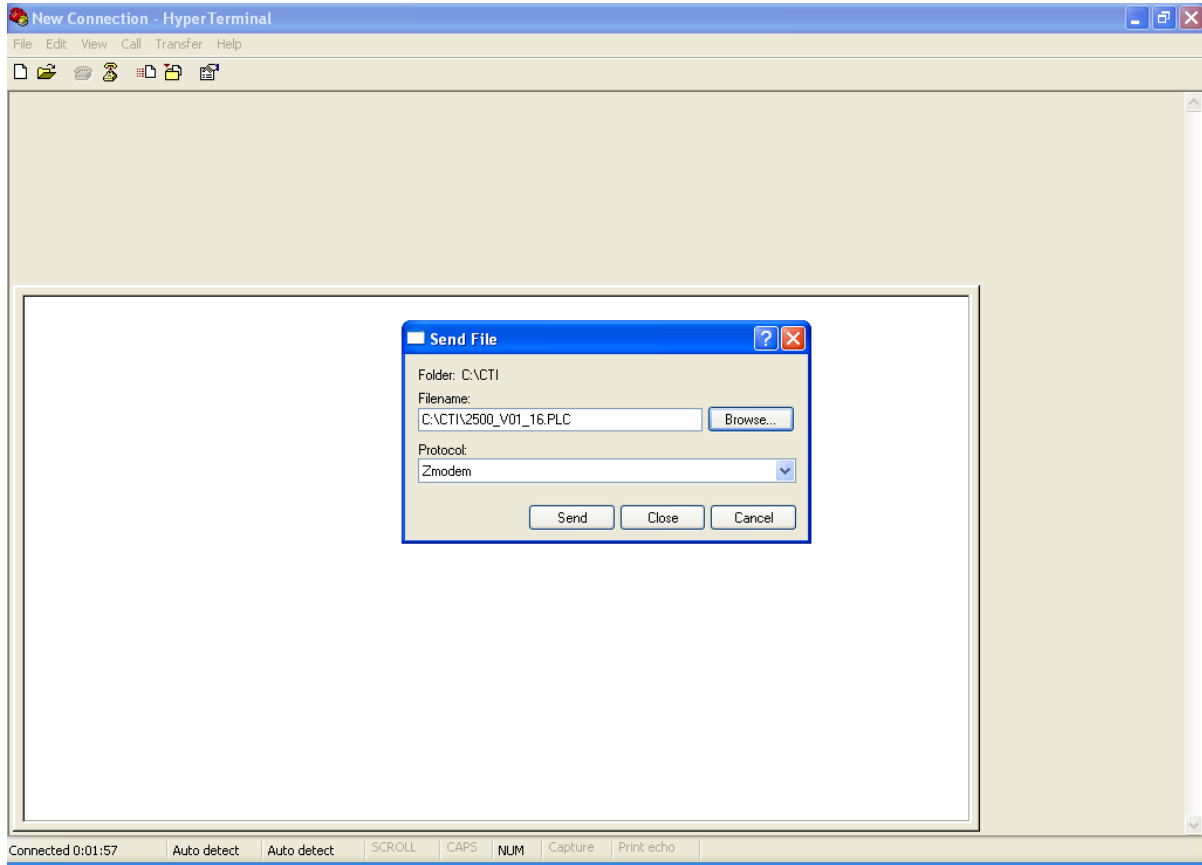

8. Start the file download by pressing 'Send'. HyperTerminal displays a window showing the status of the file transfer. Once the transfer is initiated, the MSD should display "U02"

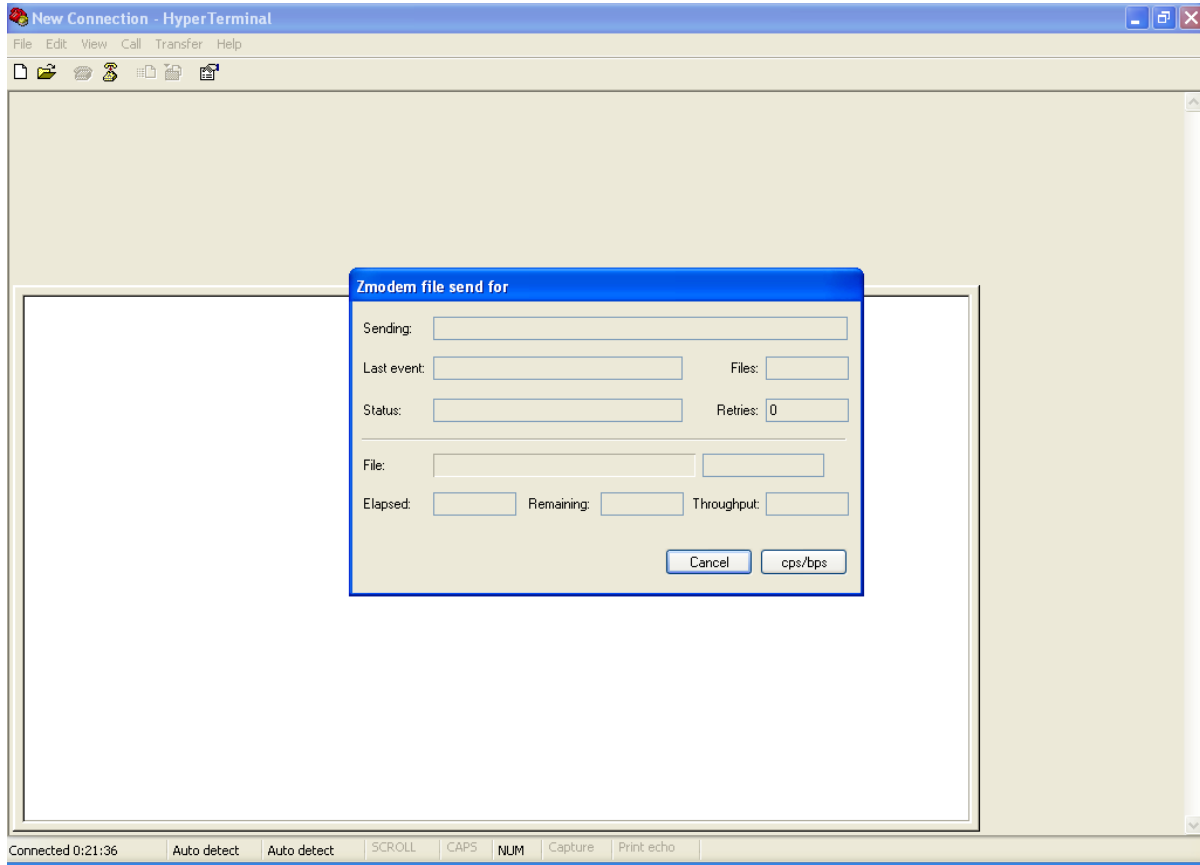

Once the transfer has completed successfully, the MSD should display "U06", indicating the controller is starting to write the new firmware to flash memory. The decimal points will flash in sequence to indicate progress.

CAUTION:

While the flash is being updated, do NOT remove power. This will result in incomplete or missing firmware components, making the controller inoperable.

Should you inadvertently lose power, rerunning the firmware update procedure and successfully completing it will allow you to use the controller in most cases.

During the update, the MSD will cycle through other update numbers as the firmware components are written to the flash. When the flash update has completed successfully, the MSD will display U00, indicating the flash has been successfully written.

9. Disconnect power from the base and remove the controller from the base.
10. Set the firmware update switch to the Normal position. See Section 2.3. Reinstall the controller in the base and apply power. The controller should start up in normal operating mode.

10.3 SD Card Method

Using the SD card to update the controller firmware (requires firmware version 5.0 or above).

10.3.1 Firmware Update Planning (SD Card Method)

In order to update the controller firmware using the SD card method, you will need:

- **A standard SD Card**
SD or SDHC Cards can be used.
- **A copy of the firmware update file**
The firmware update file can be obtained from the CTI Web site (<http://www.controltechnology.com/downloads/>) and saved on your PC.
- **A PC SD card adapter for reading and writing the SD card**
A SD card adapter that plugs into a USB slot typically can be purchased for a nominal price.
- **A base and power supply compatible with the CTI 2500 processor**
The controller must be installed in the base and powered during the firmware upgrade process.
- **The CTI 2500 controller to be updated**

10.3.2 Firmware Update Procedure (SD Card Method)

1. If the SD card does not contain the desired firmware update file (.plc), copy the file to the root directory of the SD card.

NOTE:

The SD card must contain one and ONLY one firmware update file. Firmware update files have a suffix of .plc. This file must be located in the root directory. The file loader application will not find firmware update files located in other folders.

If the root directory of the SD card contains more than one firmware update file, the update process will not proceed. If you have more than one firmware update file on the SD card, you must delete the ones you do not wish to use or locate them in a folder other than the root.

2. If the controller is installed in a base, disconnect power from the base and remove the controller from the base.
3. Set the firmware update switch to the Firmware Update position (see Section 2.3).
4. Install the unit into the base and apply power. The controller should display U01 on the multi-segment display, indicating it is waiting for you to transfer the firmware update file to the controller.

NOTE:

If the SD card is already inserted when power is first applied, the firmware update process will not proceed. You must remove the SD card and re-insert it to signal the procedure to continue.

5. Insert the SD card into the SD Flash Card Slot. Once inserted, the MSD should display “U02”. The file will then be copied from the SD card to the controller RAM. This will take only a few seconds.

NOTE:
If nothing happens when you insert the SD card, a possible cause is that you are using a SD card than that the controller does not recognize.

Once the file transfer has completed successfully, the MSD will display “U06”, indicating the controller is starting to write the new firmware to flash memory. The decimal points will flash in sequence to indicate progress.

CAUTION:
While the flash is being updated, do NOT remove power. This will result in incomplete or missing firmware components, making the controller inoperable.

Should you inadvertently loose power, rerunning the firmware update procedure and successfully completing it will allow you to use the controller, in most cases.

6. During the update, the MSD will cycle through other update numbers as the firmware components are written to the flash.
7. When the flash update has completed successfully, the MSD will display U00, indicating the flash has been successfully written.
8. Disconnect power from the base and remove the controller from the base.
9. Set the firmware update switch to the Normal position. See Section 2.3. Reinstall the controller in the base and apply power. The controller should start up in normal operating mode.

10.4 Firmware Update Status Codes

The following status codes indicate progress in updating firmware. Under normal circumstances, many actions happen so fast that a status code will not be displayed.

Status Code	Status
U00	Main Firmware File Loader has successfully finished updating the PLC system
U01	Main Firmware File Loader is initialized and waiting for firmware file transfer to begin
U02	The file transfer process has begun
U03	Validating downloaded Image File header in DRAM
U04	Validating downloaded Image File in DRAM
U05	Building the CTI Image File in DRAM.
U06	Erasing the application data communications area
U07	Erasing the FLASH area to hold the CTI Image File
U08	Writing the CTI Image File to flash memory
U09	Verifying the CTI Image File was written to flash memory properly
U10	Searching for an Image Trailer in flash memory
U11	Searching for a Boot Loader Image in the image file
U12	Validating the Boot Loader Image found in flash memory
U13	Copying the Boot Loader Image from flash memory to DRAM and verifying copy
U14	Erasing the area in flash memory to hold the downloaded bootloader

Status Code	Status
U15	Writing the downloaded bootloader to flash memory
U16	Searching for an IO Interface firmware image in flash memory
U17	Validating the IO Interface firmware image found in flash memory
U18	Copying the IO Interface firmware image from flash memory to DRAM and validating copy
U19	Writing the IO Interface firmware image to the I/O processor flash memory
U20	Checking the Image File in flash memory to see if it is used for manufacturing purposes only
U21	Checking to see if a Profibus upgrade is needed (based upon CPU hardware)
U22	Searching for a Profibus Application Image in the Image File saved in flash memory
U23	Searching for a Profibus Loader Image in the Image File saved in flash memory
U24	Validating the Profibus Application Image found in flash memory
U25	Validating the Profibus Loader Image found in flash memory
U26	Copying the Profibus Application Image from flash memory to DRAM and validating copy
U27	Copying the Profibus Loader Image from flash memory to DRAM and validating copy
U28	Writing the Profibus Application to the Profibus processor flash memory
U36	Searching for Profibus FPGA image in flash memory
U37	Validating Profibus FPGA image found in flash memory
U38	Copying Profibus FPGA image from flash memory to DRAM and validating copy
U39	Writing Profibus FPGA configuration and boot code to FPGA flash

10.5 Firmware Update Errors

If an error occurs during the firmware update procedure, the procedure will stop and wait for corrective action. An error code will be displayed on the MSD. The following table describes the error codes and the corrective action.

Error Code	Description	Corrective Action
E16	Firmware update failed	Rerun the firmware update procedure. If the error persists, contact CTI.
E17	Unable to write the firmware update status flag.	Rerun the firmware update procedure. If the error persists, contact CTI.
E18 – E25	Unable to locate or execute the main firmware file loader	Contact CTI.
E26	An error was encountered when attempting to open the SD card file	Reformat the SD card, copy the firmware file to the SD card, and rerun the firmware update procedure.
E27	The firmware update file could not be read	Delete the firmware update file, re-copy the firmware update to the SD card, and rerun the firmware update procedure. If the error persists, try using a new SD card for the firmware update.
E28	The SD card directory could not be read	Reformat the SD card, copy the firmware update file to the SD card, and rerun the firmware update procedure.
E29	No firmware update (.plc) file could be found on the SD card or more than one firmware update file was found.	One and only one firmware update file is allowed on the SD card. This file must be in the root directory. Take the necessary action to ensure that the desired firmware update file (and only the file), is located in the root directory. Once this has been done, rerun the firmware update procedure.

Error Code	Description	Corrective Action
E30	Failed to detect inserted SD card	This may be caused by inserting a non-supported or defective SD card. Rerun the firmware update procedure using another card.
E31	An SD card is already inserted	To reduce the chance of updating the firmware with the wrong firmware update file, the SD card must be inserted after power is re-applied and the firmware update process is started. Remove the SD card, cycle power, and re-insert the card after "U01" is displayed on the multi-segment display.
E32	SD Card memory region is not available	Rerun the firmware update procedure. If this error persists contact CTI.
E33 – E73	Error erasing, writing, or verifying flash.	Retry the firmware update procedure. If the error persists, contact CTI Product Support.
E74 - E79	The file transferred to the controller does not appear to be a valid Firmware Update File.	<ol style="list-style-type: none"> 1. If you encountered error E74, the error could be caused by a defective SD card. First, try the operation again using a new SD card after you copy the update file to it. 2. Ensure that the file you transferred is a firmware update file. If so, retry the firmware update procedure. If not, obtain a valid firmware update file and repeat the firmware update procedure.
E80	An error occurred while the firmware update file was being transferred to the controller.	<p>Serial Port Method</p> <p>The serial cable may have been disconnected during file transfer. Re-insert the cable. Cycle power and retry the firmware update procedure starting at step 6c.</p> <p>If the cable was not disconnected, try a different cable. If you are using the RS-2323 serial port, try using a slower baud rate.</p>
		<p>SD Card Method</p> <p>The SD card was probably removed during file transfer. Remove the SD card. Cycle power and retry the firmware update procedure starting at step 5.</p> <p>If the error persists, try using a different SD card.</p>
F42- F59	Error accessing Profibus FPGA	Retry the firmware update procedure. If the problem persists, contact CTI support.
F60- F67	Bad or Missing FPGA flash image	

If you encounter an error when restarting the controller after a firmware update, see Section 9.2 Startup Errors.

CHAPTER 11 USER PROGRAM FLASH STORAGE

11.1 Overview

NOTE

Firmware Version 3.08 or greater is required for flash memory support.

The 2500 Series processor reserves a portion of the on-board flash memory for User Program storage. Since the content of flash memory is retained when power is not present, this facility provides another option besides battery backed RAM for storing the User Program.

The on-board flash memory operates in a similar manner to a flash drive. The User Program does not execute in flash memory. It must be copied from flash memory to User Program RAM before it can be executed.

The following User Program elements are stored in flash memory:

- Relay Ladder Logic,
- Special Function Programs and Subroutines,
- Analog Loops,
- Analog Alarms,
- I/O Configuration,
- Memory Configuration,
- Profibus Configuration,
- Scan Configuration,
- Password data,
- K Memory.

NOTE

To maintain compatibility with SIMATIC 505® controllers, the 2500 Series controller does not store the contents of V memory in flash. Whenever the User Program is restored from flash, V memory is cleared. If you have values that you wish to retain, you should store them in K memory, which is written to flash, and then copy them to V memory on the first scan.

NOTE

The current values for the timer/counter and drum presets (TCP, DSP, and DCP) are not stored in flash. When the User Program is restored from flash, the presets are reset to the values stored in the RLL instructions.

WARNING

The change in V memory, Timer/Counter presets, or Drum presets may cause unexpected operation which could cause damage to equipment, personal injury, or death when the PLC is placed in RUN mode. Ensure that you have designed the program to accommodate these changes.

11.2 Using Flash Memory

Using your programming software, you can:

- Erase a program in flash memory,
- Copy a User Program from User Program RAM to flash memory,
- Select User Program RAM or flash memory as the program source,
- Copy a User Program from flash memory to User Program RAM.

NOTE

The controller must be in Program mode before you can perform flash memory operations.

NOTE

Programming software that supports both CTI 2500 Series and SIMATIC 505® systems may refer to flash memory as EEPROM.

11.2.1 Erasing a Program in Flash Memory

If a User Program is already stored in flash memory, you must erase the User Program flash area before another program can be written to it. This action is required to maintain compatibility with legacy programming software as well as to provide some protection from inadvertently overwriting a program stored in flash memory.

NOTE

If the Program Source is set to Flash, it will be automatically changed to RAM after the flash is erased.

11.2.2 Copying a program to Flash Memory

Once the User Program flash is cleared, you can store the User Program in flash memory by copying the User Program from RAM to Flash.

11.2.3 Selecting the User Program Source

Your programming software allows you to choose between RAM and Flash as the program source. Once a User Program has been stored in flash memory, selecting Flash as the program source will clear the User Program RAM and copy the User Program from flash memory to the User Program RAM area.

NOTE

Because V memory is not stored in flash memory, changing the User Program Source to Flash will clear V memory.

11.2.4 Copying a User Program from Flash to User Program RAM

Using your programming software, you can copy a program stored in flash to User Program RAM using your programming software. When this action is taken, User Program RAM will be cleared and the User Program stored in flash will be copied from flash.

NOTE

Because V memory is not stored in flash, this operation will result in V memory being cleared.

11.3 Power-On Start Operation

The following table describes how the Series 2500 controller operates when AC power is cycled.

Program Source	Battery Condition	Controller Operation
RAM	Good	Start up in previous mode using User Program in RAM.
RAM	Not Installed, Bad, or Off	Start up in PROGRAM mode with User Program RAM cleared.
Flash	Good	Start up in previous mode using User Program in RAM
Flash	Not Installed, Bad, or Off	Copy User Program from Flash to RAM. Start up in RUN mode. <i>See following note.</i>

NOTE

When the User Program is copied from Flash to RAM, timer/counter presets, drum presets, loop parameters, and alarm parameters will be restored to the values saved in EEPROM. Because V memory is not stored in flash, this operation will result in V memory being cleared.

11.4 Restrictions When the Program Source is Flash

When Flash is selected as the Program Source, you will be prevented from making the following changes to the User Program:

- Modifying the RLL program,
- Creating or modifying a Special Function program or subroutine,
- Creating or modifying an Analog Loop,
- Creating or modifying an Analog Alarm,
- Modifying the I/O Configuration,
- Modifying the memory configuration,
- Modifying K memory contents,
- Modifying the User Password,
- Modifying the task codes per scan variable,
- Modifying the scan watchdog value.

NOTE

Changes to the Loop and Alarm parameters, Timer/Counter presets, and Drum presets can be made by HMI devices using the applicable task codes. These values will be restored to the values saved in flash when the User Program is copied from flash.

APPENDIX A. - ERROR CODES

Startup Error Codes

Error Number	Description	Corrective Action
E01	Invalid Product Model ID	Contact CTI Product Support
E02	5V power is not present.	Cycle power. If the problem persists contact CTI Product Support.
E03 – E08	Unused	
E09	The memory region between the main processor and the I/O controller could not be set up for sharing. This is likely a hardware problem.	Cycle power. If the problem persists contact CTI Product Support.
E10	The battery backed RAM could not be partitioned. This is likely a hardware problem.	
E11	The battery backed RAM could not be partitioned for the event log. This is likely a hardware problem.	
E12	Could not allocate a block of memory in dynamic RAM for the media task. This is likely a hardware problem.	
E13	Could not create a software task “activity” for the media task. This is likely a hardware problem.	
E14	Media task could not initialize its access to its shared memory regions. This is likely a hardware problem.	
E89	Problem reading flash during powerup	

Fatal Error Codes

Code	Description	Correction
0102	System Reset: Cause Unknown The reset was not caused by the hardware watchdog timer nor the operating system exception handler.	Use Partial or Complete Restart to clear this error. Contact CTI product support if this error persists
0103	Hardware Watchdog Timeout The hardware watchdog timer expired, resetting the controller.	Use Partial or Complete Restart to clear this error. Contact CTI product support if this error persists.
010b	Abnormal Shutdown Indicates that power was lost before the controller could complete an orderly shutdown.	Use Partial or Complete Restart to clear this error.
010d	User Program Flash Restore Error Indicates that the program stored in flash could not be used.	After clearing this error using Partial or Complete Restart, you must erase the user program in flash, reload the program to RAM, and then save it to flash.
0113	Scan Watchdog Timeout This error indicates that the actual scan time exceeded the watchdog setting.	<p>A common cause of this problem is setting the cyclic RLL cycle time too small, so that other scan elements do not get enough time to run. If you are using cyclic RLL, try increasing the cycle time.</p> <p>This can also be caused by a Special Function Program (SFP) that is executed inline. An inline SFP runs to completion within the scan in which it is called. If the program contains an endless loop or otherwise consumes too much time, it will cause a scan watchdog timeout. See the CTI 2500 Series Programming Reference Manual for more information.</p> <p>Another cause of the problem could be excessive bursts of broadcast traffic on the network connected to the local Ethernet port. You should analyze the traffic and, if necessary, eliminate broadcast bursts, by using Ethernet switches that offer broadcast storm protection.</p> <p>If errors persist, you may need to increase the value of the scan watchdog.</p>
0114	Compiled RLL Checksum Error Indicates the compiled RLL has been corrupted.	These errors may be caused by to excessive conductive or radiated interference affecting the controller memory.
0134	Compiled SF Checksum Error This error indicates that one or more compiled SF programs/subroutines have been corrupted.	<p>Use Partial or Complete Restart to clear this error.</p> <p>If this problem persists, ensure the system is properly grounded.</p>

Code	Description	Correction
0300	Operating System Error Indicates that an error has been detected in the operation of the system firmware.	Error details can be obtained from the system event log. If this error persists, contact CTI product support.
0400	Diagnostic Error Indicates that a general diagnostic error has occurred.	Error details can be obtained from the system event log.
0600	Hardware Failure Indicates that a failure in a hardware component has been detected.	Error details can be obtained from the system event log.
0608	System Clock Failure. Indicates the system clock cannot be accessed.	To clear this error you must cycle power to the controller. If the problem persists, contact CTI Product Support.
060b	L Memory Invalid: Power loss during in-progress RLL edit operation.	After clearing this error, you must reload the user program.
060C	L Memory Invalid: Power loss during L memory resize operation	After clearing this error, you must reload the user program.
060d	S Memory Invalid: Power loss during in-progress S memory edit operation.	After clearing this error, you must reload the user program.
060F	System service failure.	To clear this error, you must cycle power to the controller. If the problem persists, contact CTI Product Support.
0611	RLL Source checksum error detected during power-up start. Indicates that the RLL is invalid and cannot be compiled.	After clearing the fatal error using Partial or Complete Restart, you must reload the user program to prevent this error from re-occurring.
0612	S Memory checksum error detected during power-up start. Indicates the Special Function source is invalid and cannot be compiled.	After clearing the fatal error using Partial or Complete Restart, you must reload the user program to prevent this error from re-occurring.
0615	Startup RLL compile failed Indicates the RLL failed to compile during a power-on start	Error details can be obtained from the system event log. After clearing the fatal error using Partial or Complete Restart, you will need to correct RLL errors before it will compile.
0616	Startup SFP/SFS compile failed Indicates at least one SFP or SFS failed to compile during a power-on start.	Error details can be obtained from the system event log. After clearing the fatal error using Partial or Complete Restart, you will need to correct the SFP or SFS error and re-enable the program or subroutine.
0618	I/O Interface Timeout Indicates the I/O interface failed to respond to a request from the main processor.	Clear the error using Partial or Complete Restart. If this error persists, contact CTI product support.

Code	Description	Correction
0620	Profibus I/O Error Indicates that the Profibus interface experienced a fatal error.	Error details can be obtained from the system event log. Clear the error using Partial or Complete restart. If the action above does not clear the error, remove the battery and cycle power. If the error persists, contact CTI product support.
0700	Control block data is invalid	These errors indicate that memory has been corrupted or that a problem exists in the OS firmware. After clearing the error using Partial or Complete Restart, try reloading the program. If the error persists, contact CTI product support.
0701	Expression evaluation failed due to corrupt or invalid expression	
0702	SF Execution failed--Program evaluation data is invalid	
0703	Expression evaluation failed due to corrupt or invalid parameter	
0704	SF number from RLL is invalid	

Task Code Errors

To aid in diagnosing errors, the following table provides a list of all task code error codes returned in a task code 00 error reply.

Error Code (Hexadecimal)	Description
01	Reset Current Transaction
02	Address out of Range (other than ladder logic)
03	Requested data not found
04	Illegal Task Code Request
05	Request exceeds available memory
06	Diagnostic fail on power up
07	Fatal error detected
08	Keylock/password protection error
09	Incorrect amount of data sent with request
0A	Illegal request in current operational mode
0B	Network was not deleted
0C	Attempted write operation did not verify
0D	Illegal number of ASCII characters received
0E	Illegal request when running from EEPROM or flash
0F	Data not inserted
10	Data not written
11	Illegal data sent with command
12	Invalid operation with NIM local/remote mode (obsolete)
13	The store and forward buffer is busy
14	No response from special function module
15	Illegal instruction found in program memory (may include memory address)
16	Attempted to write to protected variable (e.g. TCC, TCP)
17	No response from PLC (e.g. single scan not performed)

Error Code (Hexadecimal)	Description
18	Requested memory size exceeds total available memory
19	Requested memory size is not multiple of block allocation size
1A	Requested memory size is less than minimum defined value
1B	Requested memory size is larger than maximum defined value
1C	PLC busy – cannot complete requested operation
1D	Communications error in HOLD mode – Transition to Run not allowed
1E	Port Lockout is active
1F	Attempting to delete active program via reconfiguration
20	Program load in progress or invalidated
21	I/O configuration error –too many points
22	I/O configuration error – attempt to assign Output point to multiple applications
23-3E	Unused
3F	Bus error detected
40	Operating system error detected
41	Invalid control block type
42	Control block number out of range
43	Control block does not exist
44	Control Block already exists
46	Offset out of range
47	Arithmetic error detected while writing Loop or Loop Alarm parameters
48	Invalid SF program type
49	Instruction number or RAMP/SOAK step number out of range
4A	Attempt to access an integer variable as a real
4B	Attempt to access a real variable as an integer
4C	Task code buffer overflow – too much data requested
4D	Control block size error (cannot exceed 32767 bytes)
50	Task code request buffer too large
51	Invalid SF statement size
52	Invalid return value
53	Attempt to execute a cyclic statement in a non-cyclic SF program
54	Control block is disabled
55	Control block is not disabled
56	Attempt to perform a FSTR_OUT SF statement on an empty FIFO
57	Attempt to perform a FSTR_INT SF statement on a full FIFO
58	Stack overflow while evaluating a MATH, IF-THEN, or IMATH statement
59	Maximum SF subroutine nesting level exceeded (maximum = 4)
5A	Arithmetic Overflow
5B	Invalid operator in and IF, MATH, or IMATH expression
5C	S memory overflow
5D	Attempt to divide by 0
60	Invalid data type code
61	RAMP/SOAK step type mismatch

Error Code (Hexadecimal)	Description
62	Invalid code
63-67	Unused
68	Data cache full (ECC1 module)
69	CAMP server not enabled (ECC1 module)
70	NITP message count error
71	NITP invalid character error
72	NITP message too long
73	NITP Checksum error
74-8F	Reserved
90	Invalid IP parameter
91	IP parameter set failed
92-FD	Unused
FE	Normal I/O Error
FF	DAM error

APPENDIX B. – SYSTEM STATUS WORDS

The CTI 2500 controller maintains a collection of status words that may be used by user programs or operator interface equipment to monitor the status of the controller subsystems. The following table describes the status words.

NOTE: Status Words 243 and above are not supported by Siemens 545 or 555 controllers.

Word	Description																																
STW 1	Misc. Status and Non-Fatal Errors																																
Bit 1:3	Unused																																
Bit 4	Password has been entered																																
Bit 5	Password is currently disabled																																
Bit 6	User Program Error Flag (RLL). See STW 200 for error code.																																
Bit 7	RLL Subroutine Stack Overflow																																
Bit 8	Time of Day Clock Failure																																
Bit 9	Unused																																
Bit 10	SF Module Communications Failure																																
Bit 11	Previous RLL Instruction Failed																																
Bit 12	I/O Module Failure																																
Bit 13	Unused																																
Bit 14	Scan Overrun																																
Bit 15	Battery Low																																
Bit 16	Source RLL Checksum Error																																
STW 2	<p>Base Controller Status</p> <p>The most significant bit (1) corresponds to base 15 and the least significant bit (16) corresponds to the local base (0) as shown below.</p> <table border="1" style="margin-left: 20px;"> <thead> <tr style="background-color: #ADD8E6;"> <th>1</th><th>2</th><th>3</th><th>4</th><th>5</th><th>6</th><th>7</th><th>8</th><th>9</th><th>10</th><th>11</th><th>12</th><th>13</th><th>14</th><th>15</th><th>16</th> </tr> </thead> <tbody> <tr> <td>15</td><td>14</td><td>13</td><td>12</td><td>11</td><td>10</td><td>9</td><td>8</td><td>7</td><td>6</td><td>5</td><td>4</td><td>3</td><td>3</td><td>1</td><td>0</td> </tr> </tbody> </table> <p>Corresponding bit is set to 1 if :</p> <ul style="list-style-type: none"> • The base poll flag is not set (polling disabled), or • The base poll flag is set and the base is not present (not online) or is a failed state (unable to log-in). 	1	2	3	4	5	6	7	8	9	10	11	12	13	14	15	16	15	14	13	12	11	10	9	8	7	6	5	4	3	3	1	0
1	2	3	4	5	6	7	8	9	10	11	12	13	14	15	16																		
15	14	13	12	11	10	9	8	7	6	5	4	3	3	1	0																		

STW 3 - STW 9	<p>Status of DP channel slaves. Set to 0 if slave is online, configured, and enabled. The least significant bit (16) of Word 3 corresponds to Slave #1. See the table below.</p> <table border="1"> <thead> <tr> <th>Word</th> <th>1</th> <th>2</th> <th>3</th> <th>4</th> <th>5</th> <th>6</th> <th>7</th> <th>8</th> <th>9</th> <th>10</th> <th>11</th> <th>12</th> <th>13</th> <th>14</th> <th>15</th> <th>16</th> </tr> </thead> <tbody> <tr> <td>3</td> <td>16</td> <td>15</td> <td>14</td> <td>13</td> <td>12</td> <td>11</td> <td>10</td> <td>9</td> <td>8</td> <td>7</td> <td>6</td> <td>5</td> <td>4</td> <td>3</td> <td>2</td> <td>1</td> </tr> <tr> <td>4</td> <td>32</td> <td>31</td> <td>30</td> <td>29</td> <td>28</td> <td>27</td> <td>26</td> <td>25</td> <td>24</td> <td>23</td> <td>22</td> <td>21</td> <td>20</td> <td>19</td> <td>18</td> <td>17</td> </tr> <tr> <td>5</td> <td>48</td> <td>47</td> <td>46</td> <td>45</td> <td>44</td> <td>43</td> <td>42</td> <td>41</td> <td>40</td> <td>39</td> <td>38</td> <td>37</td> <td>36</td> <td>35</td> <td>34</td> <td>33</td> </tr> <tr> <td>6</td> <td>64</td> <td>63</td> <td>62</td> <td>61</td> <td>60</td> <td>59</td> <td>58</td> <td>57</td> <td>56</td> <td>55</td> <td>54</td> <td>53</td> <td>52</td> <td>51</td> <td>50</td> <td>49</td> </tr> <tr> <td>7</td> <td>80</td> <td>79</td> <td>78</td> <td>77</td> <td>76</td> <td>75</td> <td>74</td> <td>73</td> <td>72</td> <td>71</td> <td>70</td> <td>69</td> <td>68</td> <td>67</td> <td>66</td> <td>65</td> </tr> <tr> <td>8</td> <td>96</td> <td>95</td> <td>94</td> <td>93</td> <td>92</td> <td>91</td> <td>90</td> <td>89</td> <td>88</td> <td>87</td> <td>86</td> <td>85</td> <td>84</td> <td>83</td> <td>82</td> <td>81</td> </tr> <tr> <td>9</td> <td>112</td> <td>111</td> <td>110</td> <td>109</td> <td>108</td> <td>107</td> <td>106</td> <td>105</td> <td>104</td> <td>103</td> <td>102</td> <td>101</td> <td>100</td> <td>99</td> <td>98</td> <td>97</td> </tr> </tbody> </table>	Word	1	2	3	4	5	6	7	8	9	10	11	12	13	14	15	16	3	16	15	14	13	12	11	10	9	8	7	6	5	4	3	2	1	4	32	31	30	29	28	27	26	25	24	23	22	21	20	19	18	17	5	48	47	46	45	44	43	42	41	40	39	38	37	36	35	34	33	6	64	63	62	61	60	59	58	57	56	55	54	53	52	51	50	49	7	80	79	78	77	76	75	74	73	72	71	70	69	68	67	66	65	8	96	95	94	93	92	91	90	89	88	87	86	85	84	83	82	81	9	112	111	110	109	108	107	106	105	104	103	102	101	100	99	98	97
Word	1	2	3	4	5	6	7	8	9	10	11	12	13	14	15	16																																																																																																																									
3	16	15	14	13	12	11	10	9	8	7	6	5	4	3	2	1																																																																																																																									
4	32	31	30	29	28	27	26	25	24	23	22	21	20	19	18	17																																																																																																																									
5	48	47	46	45	44	43	42	41	40	39	38	37	36	35	34	33																																																																																																																									
6	64	63	62	61	60	59	58	57	56	55	54	53	52	51	50	49																																																																																																																									
7	80	79	78	77	76	75	74	73	72	71	70	69	68	67	66	65																																																																																																																									
8	96	95	94	93	92	91	90	89	88	87	86	85	84	83	82	81																																																																																																																									
9	112	111	110	109	108	107	106	105	104	103	102	101	100	99	98	97																																																																																																																									
STW 10	<p>Dynamic Scan Time Scan time of the previous scan.</p>																																																																																																																																								
STW 11: STW 26	<p>I/O Module Status STW 11 represents the local base STW 12 – 26 represent remote bases 1 – 15. For all words, the most significant bit (1) represents slot 16 and the least significant bit (16) represents slot 1 as shown below.</p> <table border="1"> <thead> <tr> <th>1</th> <th>2</th> <th>3</th> <th>4</th> <th>5</th> <th>6</th> <th>7</th> <th>8</th> <th>9</th> <th>10</th> <th>11</th> <th>12</th> <th>13</th> <th>14</th> <th>15</th> <th>16</th> </tr> </thead> <tbody> <tr> <td>16</td> <td>15</td> <td>14</td> <td>13</td> <td>12</td> <td>11</td> <td>10</td> <td>9</td> <td>8</td> <td>7</td> <td>6</td> <td>5</td> <td>4</td> <td>3</td> <td>2</td> <td>1</td> </tr> </tbody> </table> <p>A bit is set to 0 if the module status is good. It is set to 1 if any of the following conditions is true:</p> <ul style="list-style-type: none"> • Installed module does not match configuration for the slot • The slot is configured but no module is installed in the slot. • The slot is not configured but a module is installed. • Module fail is asserted and module fail bit is set 	1	2	3	4	5	6	7	8	9	10	11	12	13	14	15	16	16	15	14	13	12	11	10	9	8	7	6	5	4	3	2	1																																																																																																								
1	2	3	4	5	6	7	8	9	10	11	12	13	14	15	16																																																																																																																										
16	15	14	13	12	11	10	9	8	7	6	5	4	3	2	1																																																																																																																										
STW 27: STW 138	<p>Profibus RBC Module Status. Provides module status for modules in a 505 base using a Profibus RBC. Status Word 27 corresponds to Profibus RBC slave # 1. Subsequent words correspond to Slave # 2, Slave # 3, etc. For all words, the most significant bit represents slot 16 and the least significant bit (16) represents slot 1 as shown below.</p> <table border="1"> <thead> <tr> <th>1</th> <th>2</th> <th>3</th> <th>4</th> <th>5</th> <th>6</th> <th>7</th> <th>8</th> <th>9</th> <th>10</th> <th>11</th> <th>12</th> <th>13</th> <th>14</th> <th>15</th> <th>16</th> </tr> </thead> <tbody> <tr> <td>16</td> <td>15</td> <td>14</td> <td>13</td> <td>12</td> <td>11</td> <td>10</td> <td>9</td> <td>8</td> <td>7</td> <td>6</td> <td>5</td> <td>4</td> <td>3</td> <td>2</td> <td>1</td> </tr> </tbody> </table> <p>A bit is set to 0 if the module status is good. It is set to 1 if any of the following conditions is true:</p> <ul style="list-style-type: none"> • Installed module does not match configuration for the slot • The slot is configured but no module is installed in the slot. • The slot is not configured but a module is installed. 	1	2	3	4	5	6	7	8	9	10	11	12	13	14	15	16	16	15	14	13	12	11	10	9	8	7	6	5	4	3	2	1																																																																																																								
1	2	3	4	5	6	7	8	9	10	11	12	13	14	15	16																																																																																																																										
16	15	14	13	12	11	10	9	8	7	6	5	4	3	2	1																																																																																																																										
STW 139	<p>Number of Forced Bits. Current count of forced X, Y, and C.</p>																																																																																																																																								
STW 140	<p>Number of Forced Words Current count of forced WX and WY.</p>																																																																																																																																								

STW 141	BCD Time of Day – Word 1
Bit 1 – 4	Year – Tens
Bit 5 – 8	Year – Units
Bit 9 – 12	Month – Tens
Bit 13 - 16	Month - Units
STW 142	BCD Time of Day – Word 2
Bit 1 – 4	Day - Tens
Bit 5 – 8	Day - Units
Bit 9 – 12	Hour - Tens
Bit 13 - 16	Hour - Units
STW 143	BCD Time of Day – Word 3
Bit 1 – 4	Minute - Tens
Bit 5 – 8	Minute - Units
Bit 9 – 12	Second - Tens
Bit 13 - 16	Second - Units
STW 144	BCD Time of Day – Word 4
Bit 1 – 4	Second - Tenths
Bit 5 – 8	Second - Hundredths
Bit 9 – 12	Unused – Set to 0
Bit 13 - 16	Day of Week
STW 145	Remote I/O Channel Receive Errors Cumulative count of all receive errors on the remote I/O channel
STW 146	Remote I/O Channel Timeout Errors Cumulative counts of all timeout errors on the remote I/O channel
STW 147	Number of DP related errors Counts all DP errors on the Profibus Channel. This includes timeouts, etc.
STW 148	Number of token-related errors Counts the token related errors on the Profibus channel.
STW 149: STW 161	Not used
STW 162	Analog Non-Fatal Errors
Bit 1	Unused
Bit 2	Unused
Bit 3	Loops are overrunning
Bit 4	Analog Alarms are overrunning
Bit 5	Cyclic SF programs are overrunning
Bit 6	Normal SF Queue is Full
Bit 7	Priority SF Queue is Full
Bit 8	Cyclic SF Queue is Full
Bit 9	Error occurred during loop calculation
Bit 10	Error occurred during analog alarm calculation
Bit 11	A control block is disabled
Bit 12	Attempt to execute undefined SFPGM or SFSUB
Bit 13	Attempt to execute restricted SFPGM from RLL
Bit 14 - 15	Unused
Bit 16	Unused
STW 163	RLL Subroutine Stack Overflow Contains the number of the RLL subroutine that caused a stack overflow
STW 164 STW 165	Source RLL Checksum Contains checksum as a 32 bit unsigned integer
STW 166 STW 167	Compiled RLL Checksum Contains checksum as a 32 bit unsigned integer

STW 168	<p>Dual RBC Status (Remote I/O) Status of 0 indicates that the dual RBCs are present and good. 1 indicates a bad RBC or a single RBC. The most significant bit (1) represents base 15 and the least significant bit (16) represents the local base (0).</p> <table border="1"> <tr> <td>1</td><td>2</td><td>3</td><td>4</td><td>5</td><td>6</td><td>7</td><td>8</td><td>9</td><td>10</td><td>11</td><td>12</td><td>13</td><td>14</td><td>15</td><td>16</td> </tr> <tr> <td>15</td><td>14</td><td>13</td><td>12</td><td>11</td><td>10</td><td>9</td><td>8</td><td>7</td><td>6</td><td>5</td><td>4</td><td>3</td><td>3</td><td>1</td><td>0</td> </tr> </table>	1	2	3	4	5	6	7	8	9	10	11	12	13	14	15	16	15	14	13	12	11	10	9	8	7	6	5	4	3	3	1	0
1	2	3	4	5	6	7	8	9	10	11	12	13	14	15	16																		
15	14	13	12	11	10	9	8	7	6	5	4	3	3	1	0																		
STW 169: STW 175	Unused																																
STW 176	<p>Redundant Power Supply Status Status of 0 indicates that the base is present, dual supplies are present, and they are both good. Status of 1 indicates that a power supply is bad or only a single power supply is present. The most significant bit (1) represents base 15 and the least significant bit (16) represents the local base (0).</p> <table border="1"> <tr> <td>1</td><td>2</td><td>3</td><td>4</td><td>5</td><td>6</td><td>7</td><td>8</td><td>9</td><td>10</td><td>11</td><td>12</td><td>13</td><td>14</td><td>15</td><td>16</td> </tr> <tr> <td>15</td><td>14</td><td>13</td><td>12</td><td>11</td><td>10</td><td>9</td><td>8</td><td>7</td><td>6</td><td>5</td><td>4</td><td>3</td><td>3</td><td>1</td><td>0</td> </tr> </table>	1	2	3	4	5	6	7	8	9	10	11	12	13	14	15	16	15	14	13	12	11	10	9	8	7	6	5	4	3	3	1	0
1	2	3	4	5	6	7	8	9	10	11	12	13	14	15	16																		
15	14	13	12	11	10	9	8	7	6	5	4	3	3	1	0																		
STW 177: STW 183	Unused																																
STW 184	Module Mismatch or Unclaimed MODFAIL signal																																
Bit 1	Set to 1 if there is a module mismatch on any base																																
Bit 2-4	Unused																																
Bit 5 – 8	Number of base with mismatch																																
Bit 9 - 16	Unused																																
STW 185: STW 190	Unused																																
STW 191	Serial Port Print Status																																
Bit 1	Print Busy – The port is currently sending characters from the print buffer																																
Bit 2	Configuration Error - The serial port is not configured for print output. The print jumper is missing or is in the wrong position.																																
Bit 3	Print Buffer Overflow – The buffer is full, additional characters have been discarded																																
Bit 4	Hardware Error – Serial port UART failure																																
Bit 5 - 16	Unused																																
STW 192	Discrete Execution Scan Time Indicates the time spent in the last discrete scan cycle.																																
STW 193: STW 199	Unused																																

STW 200	<p>User Program Error Cause The following error codes are associated with bit 6 of STW1.</p> <table border="0"> <thead> <tr> <th>Code</th> <th>Description</th> </tr> </thead> <tbody> <tr><td>0</td><td>No Error</td></tr> <tr><td>1</td><td>Unused</td></tr> <tr><td>2</td><td>Unused</td></tr> <tr><td>3</td><td>Unused</td></tr> <tr><td>4</td><td>Subroutine nesting level exceeded</td></tr> <tr><td>5</td><td>Table Overflow</td></tr> <tr><td>6</td><td>Attempt to call a non-existent subroutine</td></tr> <tr><td>7</td><td>Unused</td></tr> <tr><td>8</td><td>SF Program has not been compiled or does not exist</td></tr> <tr><td>9</td><td>SF Program is currently disabled</td></tr> <tr><td>10</td><td>SF Program type is Restricted or Cyclic</td></tr> <tr><td>11</td><td>SF Program or Subroutine is being edited</td></tr> <tr><td>12</td><td>Unused</td></tr> <tr><td>13</td><td>PID Loop is not configured</td></tr> <tr><td>14</td><td>PID Loop is disabled</td></tr> </tbody> </table>	Code	Description	0	No Error	1	Unused	2	Unused	3	Unused	4	Subroutine nesting level exceeded	5	Table Overflow	6	Attempt to call a non-existent subroutine	7	Unused	8	SF Program has not been compiled or does not exist	9	SF Program is currently disabled	10	SF Program type is Restricted or Cyclic	11	SF Program or Subroutine is being edited	12	Unused	13	PID Loop is not configured	14	PID Loop is disabled
Code	Description																																
0	No Error																																
1	Unused																																
2	Unused																																
3	Unused																																
4	Subroutine nesting level exceeded																																
5	Table Overflow																																
6	Attempt to call a non-existent subroutine																																
7	Unused																																
8	SF Program has not been compiled or does not exist																																
9	SF Program is currently disabled																																
10	SF Program type is Restricted or Cyclic																																
11	SF Program or Subroutine is being edited																																
12	Unused																																
13	PID Loop is not configured																																
14	PID Loop is disabled																																
STW 201	User Program(RLL) First Scan Flags																																
Bit 1	First Scan After Compile																																
Bit 2	First scan after Program Mode																																
Bit 3	First scan after Edit Mode																																
Bit 4	First scan after Auto Recompile																																
Bit 5 – 8	Unused																																
Bit 9	First Scan following a Battery Bad Power Up restart																																
Bit 10	First Scan following a Battery Good Power Up restart (or power-on start)																																
Bit 11	First Scan following a Complete Restart																																
Bit 12	First Scan following a Partial Restart																																
Bit 13 – 16	Unused																																
STW 202: STW 208	Unused																																
STW 210	<p>Remote I/O Base Poll Enable Flags The bit corresponding to the base is set to 1 when the base is enabled for polling. The most significant bit (1) represents base 15 and the least significant bit (16) corresponds to the local base (base 0).</p> <table border="1"> <thead> <tr> <th>1</th><th>2</th><th>3</th><th>4</th><th>5</th><th>6</th><th>7</th><th>8</th><th>9</th><th>10</th><th>11</th><th>12</th><th>13</th><th>14</th><th>15</th><th>16</th> </tr> </thead> <tbody> <tr> <td>15</td><td>14</td><td>13</td><td>12</td><td>11</td><td>10</td><td>9</td><td>8</td><td>7</td><td>6</td><td>5</td><td>4</td><td>3</td><td>3</td><td>1</td><td>0</td> </tr> </tbody> </table>	1	2	3	4	5	6	7	8	9	10	11	12	13	14	15	16	15	14	13	12	11	10	9	8	7	6	5	4	3	3	1	0
1	2	3	4	5	6	7	8	9	10	11	12	13	14	15	16																		
15	14	13	12	11	10	9	8	7	6	5	4	3	3	1	0																		

STW 211: STW 217	Profibus Poll Enable Flags The corresponding bit is set to 1 when the slave is defined and enabled for polling. The least significant bit (16) of STW 211 corresponds to Slave #1. See table below.															
Word	1	2	3	4	5	6	7	8	9	10	11	12	13	14	15	16
211	16	15	14	13	12	11	10	9	8	7	6	5	4	3	2	1
212	32	31	30	29	28	27	26	25	24	23	22	21	20	19	18	17
213	48	47	46	45	44	43	42	41	40	39	38	37	36	35	34	33
214	64	63	62	61	60	59	58	57	56	55	54	53	52	51	50	49
215	80	79	78	77	76	75	74	73	72	71	70	69	68	67	66	65
216	96	95	94	93	92	91	90	89	88	87	86	85	84	83	82	81
217	112	111	110	109	108	107	106	105	104	103	102	101	100	99	98	97
STW 218	Unused															
STW 219	RLL Task Overrun The bit corresponding to the RLL task is set if the RLL task does not complete in the user specified cycle time. The most significant bit (bit 1) corresponds to RLL Task 1.															
STW 220: STW 222	Unused															
STW 223 STW 224	Binary Time of Day Contains the relative millisecond of the current day expressed as a 32 bit unsigned integer.															
STW 225	Binary Relative Day Contains the relative day, with January 1, 1984 being day 0.															
STW 226	Time of Day Status															
Bit 1	1 = Current time is prior to time reported in the last Task 1 RLL scan															
Bit 2 – 9	Reserved															
Bit 10	1 = Time is Valid (has been Set)															
Bit 11	Unused															
Bit 12 - 13	Time Resolution 00 = Time Resolution is .001 second 01 = Time Resolution is .01 second 02 = Time Resolution is 0.1 second 03 = Time Resolution is 1 second															
Bit 14 - 16	Reserved															
STW 227: STW 228	Unused															
STW 229: STW 230	Unused															
STW 231	Profibus I/O Status															
Bit 1	1 = DP in Operate State – inputs available, outputs driven															
Bit 2	1 = DP in Clear State – Inputs available															
Bit 3	1 = Error: Unable to download configuration to Profibus interface															
Bit 4	1 = Error: Unable to retrieve slave diagnostic data from Profibus interface															
Bit 5	1 = Error: DP bus error															
Bit 6	1 = One or more DP slaves expected to be in data exchange mode are not operational.															
Bit 7 – 15	Unused.															
Bit 16	1= DP Bus has not been configured and activated															

STW 232: STW 238	Profibus I/O Slave Diagnostic Status The corresponding bit will be set to 1 if the slave signals a diagnostic that has not been read by a RSD RLL instruction. The least significant bit (16) of STW 232 corresponds to Slave # 1. See table below.															
Word	1	2	3	4	5	6	7	8	9	10	11	12	13	14	15	16
232	16	15	14	13	12	11	10	9	8	7	6	5	4	3	2	1
233	32	31	30	29	28	27	26	25	24	23	22	21	20	19	18	17
234	48	47	46	45	44	43	42	41	40	39	38	37	36	35	34	33
235	64	63	62	61	60	59	58	57	56	55	54	53	52	51	50	49
236	80	79	78	77	76	75	74	73	72	71	70	69	68	67	66	65
237	96	95	94	93	92	91	90	89	88	87	86	85	84	83	82	81
238	112	111	110	109	108	107	106	105	104	103	102	101	100	99	98	97
STW 239: STW 240	Source SF Program/SF Subroutine Checksum															
STW 241: STW 242	Compiled SF Program/SF Subroutine Checksum															
STW 243	Reserved															
STW 244	Additional Controller Status Flags															
Bit 1	Controller Mode (0 = Program Mode, 1 = Run mode)															
Bit 2	Scan Type (0 = Variable, 1 = Fixed)															
Bit 3	User Program Source (0 = RAM, 1 = Flash)															
Bit 4	Ethernet Port Link Status (1= Connected)															
Bit 5	TCP/IP Network Status (1 = TCP/IP Stack is Operational)															
Bit 6	Duplicate IP Address Status (1 = Duplicate Detected)															
Bit 7 - 16	Reserved															
STW 245	Additional Controller Error Status															
Bit 1	Fatal Error Flag (1 = Fatal Error Present).															
Bit 2	Reserved															
Bit 3	Remote I/O Base Failure (1 = One or more bases are not communicating) A base that is configured and enabled cannot be logged in.															
Bit 4 - 16	Reserved															
STW 246	Fatal Error Code Contains the fatal error code when a fatal error is present															
STW 247- STW 257	CTI Support Diagnostics Subject to change															
STW 258- STW 259	Product Serial Number Contains the serial number of the controller stored as a 32 bit value															
STW260	Firmware Major Release Number															
STW 261	Firmware Minor Release Number															
STW 262- STW 266	CTI Support Diagnostics Subject to change															
STW 267	Data Cache Connection Status Provides status for CTI Advanced Function (AF) modules configured for communications with PLC via Data Cache interface. The bit corresponding to each instance is selected in the Data Cache configuration for that AF module. When more than one Data Cache connection is used with this PLC, the bit assigned by each AF module must be unique.															
Bit 1 - 8	Data Cache Connection Status for specified instance: ON = Connection Good – Data Transfer active OFF = Not Connected															
Bit 9- 15	Reserved															
Bit 16	When set, indicates duplicate use of a connection status bit.															

STW 268- STW 298	CTI Support Diagnostics Subject to change
STW 299	Peak Scan Time 16 bit representation
STW300	Normal Io Last Scan (msec)
STW301	Normal Io Peak Scan (msec)
STW302	Profibus Last Scan (msec)
STW303	Profibus Peak Scan (msec)
STW304	Main RLL Last Scan (msec)
STW305	Main RLL Peak Scan (msec)
STW306	Special Function Io Last Scan (msec)
STW307	Special Function Io Peak Scan (msec)
STW308	PID Loop Last Scan (msec)
STW309	PID Loop Peak Scan (msec)
STW310	Analog Alarm Last Scan (msec)
STW311	Analog Alarm Peak Scan (msec)
STW312	Cyclic SF Prog Last Scan (msec)
STW313	Cyclic SF Prog Peak Scan (msec)
STW314	Priority SF Prog Last Scan (msec)
STW315	Priority SF Prog Peak Scan (msec)
STW316	Normal SF Prog Last Scan (msec)
STW317	Normal SF Prog Peak Scan (msec)
STW318	Ladder SF Sub Last Scan (msec)
STW319	Ladder SF Sub Peak Scan (msec)
STW320	Ladder SF Sub0 Last Scan (msec)
STW321	Ladder SF Sub0 Peak Scan (msec)
STW322	Normal Comm Last Scan (msec)
STW323	Normal Comm Peak Scan (msec)
STW324	Priority Comm Last Scan (msec)
STW325	Priority Comm Peak Scan (msec)
STW326	Network Comm Last Scan (msec)
STW327	Network Comm Peak Scan (msec)
STW328	Cyclic RLL Last Execution (msec)
STW329	Total Cyclic RLL Time Last Scan (msec)
STW330	Total Cyclic RLL Execution Peak Time (msec)
STW 331- STW 454	CTI Internal Support Statistics Subject to change
STW332	RLL Compile Time Time (in msec) used for compile and storage of RLL program during last transition to RUN mode
STW333	Profibus Stack Start Time Peak Maximum time (in msec) required for Profibus processor to indicate run status after reset
STW334	Profibus Bus Parameters Download Time Peak Maximum time (in msec) required to download all Bus Parameters to Profibus processor
STW335	Profibus Slave Parameters Download Time Peak Maximum time (in msec) required to download all Slave Parameters to Profibus processor
STW336- STW399	Unused

STW 455- STW 469	<p>Remote Base Receive Errors Contains the number of times that the controller encountered an error reading the response message from the remote base.</p> <p>STW 455 corresponds to remote base 1. STW 456 – STW 469 correspond to remote bases 2 – 15.</p>
STW 470	Unused
STW 471- STW 485	<p>Abnormal Logoff Count – Remote Base 1 - 15 Contains the number of times that the controller stopped communicating with the remote base due to communications errors or response timeouts.</p> <p>STW 471 corresponds to remote base 1. STW 472 – STW 485 correspond to remote bases 2 – 15.</p>
STW 486	Unused
STW 487- STW 501	<p>Timeout Count – Remote Base 1 – 15 Contains the number of times that the base failed to respond to a request from the controller within the specified time.</p> <p>STW 487 corresponds to remote base 1. STW 488 – STW 501 correspond to remote bases 2 – 15.</p>

APPENDIX C. – IP ADDRESS INFORMATION

IP Address Nomenclature

IP Address

Every host interface on an IP network is identified by a unique IP address. This address is used to uniquely identify the host and the IP network to which the host belongs.

Each IP address consists of 32 bits, divided into four 8 bit bytes (called *octets*). An IP address is usually expressed in *dotted decimal notation*, with each octet expressed as its decimal equivalent. See the example below.

Notation	Byte 1	Byte 2	Byte 3	Byte 4
Binary	11000000	11011111	10110001	00000001
Decimal	192	223	177	1

Although an IP address is a single value, it contains two pieces of information: the *Network ID* and the *Host ID*. The Network ID identifies the IP network to which the host belongs while the Host ID identifies a specific IP host on that IP network. All IP hosts on a particular IP network must have the same network ID. Each IP host on a particular IP network must use must have unique Host ID. The IP protocol sends messages with a destination IP address that is not on the host's IP network to the designated router/gateway.

Address Classes

The Internet community originally defined network classes to accommodate networks of varying sizes. The network class can be determined based on the first octet of its IP address.

The following table summarizes the relationship between the first octet of a given address and its Network ID and Host ID fields. It also identifies the total number of Network IDs and Host IDs for each address class that participates in the Internet addressing scheme. This example uses w.x.y.z to designate the octets of the IP address.

Class	w values*	Network ID	Host ID	Number of networks	Number of hosts per net
A	1-126	w	x.y.z	126	16,777,214
B	128-191	w.x	y.z	16,384	65,534
C	192-223	w.x.y	z	2,097,151	254

* Inclusive range for the first octet in the IP address. The address 127 is reserved for loopback testing and inter-process communication on the local computer; it is not a valid network address. W values 224 – 239 are used for Class D (IP multicast).

Subnet Mask

Used alone, the designation of network classes proved to be inflexible. Assigning large numbers of devices to the same network is impractical considering performance, topology, and security constraints. The Subnet Mask, often called the Network Mask, provides a flexible means of designating the Network ID portion and Host ID portions of the network address. In modern TCP/IP implementations, the network class is largely ignored, except for setting the default subnet mask

The subnet mask is a collection of 32 bits that distinguish the network ID portion of the IP address from the host ID. Subnet masks are implemented by assigning 1's to bits that belong to the network ID and 0's to the bits that belong to the host ID. To represent the mask, the 32-bit value is converted to dotted decimal notation or CIDR (Classless Inter-Domain Routing) notation, a commonly used alternate. The CIDR notation counts the number of bits in Network ID portion of the address (bits that are set to 1). The count is preceded by a slash. See the example below.

Bits for Network Mask				Dotted Decimal Format	CIDR Format
11111111 1	00000000	00000000	00000000	255.0.0.0	/8
11111111 1	11111111	11110000	00000000	255.255.240.0	/20
11111111 1	11111111	11111111	00000000	255.255.255.0	/24

For example: when the IP address is 128.54.177.97 and the network mask is 255.255.255.0, the Network ID is 128.54.177 and the Host ID is 97. When using the CIDR format, the network mask is appended to the IP address. Thus the IP address and subnet mask shown above would be represented as 128.54.177.97 /24.

NOTE

The binary representation of a Network Mask must be a single continuous block 1's followed by a contiguous block of zeroes. When entering the Network Mask in dotted decimal notation, you must ensure that this requirement is maintained. For example, a network mask of 255.247.0.0 is not valid because the binary equivalent (11111111111101110000000000000000) violates this rule.

The Network Mask must allow at least two bits of host address. In addition, a network mask which causes the derived host ID to be 0 or a broadcast address (all Host ID bits set to 1) should not be used.

Selecting IP Addresses

If your network administrator has assigned IP addresses for the network you are using, you should obtain an IP address from the administrator.

If you are establishing your own IP addresses, you should select addresses from a block of 'private' addresses established by the Internet Assigned Numbers Authority (IANA).

The private addresses are:

- 10.0.0.0 through 10.255.255.255 (Class A)
- 172.16.0.0 through 172.31.255.255 (Class B)
- 192.168.0.0 through 192.168.255.255 (Class C)

These addresses will not be forwarded by the Internet backbone routers; therefore, you are free to use any address in this group as long as it does not conflict with the usage by your local organization.

APPENDIX D. – COMPATIBILITY

Overview

The CTI 2500 controller is designed to be compatible with customer applications that use the Siemens SIMATIC® 545 and 555 controllers. While the CTI 2500 matches or exceeds the capabilities of these processors in most aspects, there are a few areas in which the CTI 2500 operates differently.

Relay Ladder Logic

The RLL used in the controller provides equivalent instructions for all SIMATIC® 555 instructions except the XSUB instruction. External subroutines are not supported. If you download a program containing the XSUB instruction, it will be ignored.

Special Function Programs

The controller compiles SF programs and subroutines in the following situations:

- When a user program is downloaded to the PLC, if the SF program or subroutine is enabled,
- When the SF program or subroutine is enabled, if the SF program has been modified,
- During a Power Up start (following the application of power),
- When using Partial or Complete Restart to recover from a compiled checksum error.

Programs that contain errors will not be enabled. During a program download, Workshop will display a message indicating the error. Once you acknowledge the message, the download will continue, leaving the program disabled. You must correct the programming error before the program or subroutine can be enabled.

NOTE

User Programs originally written for the SIMATIC® 505 PLC that we not compiled may contain undetected errors. This can occur because the SF interpreter may never attempt to execute the instruction due to the branching logic. A common problem is that additional ENDIF statements are included or the correct number of ENDIF statements is not present.

YOU WILL NEED TO IDENTIFY AND CORRECT ANY LOGIC ERRORS BEFORE THE SFP OR SFS WILL EXECUTE.

Starting with firmware Version 4.00, the CTI 2500 controller supports all SIMATIC® 555 Special Function instructions.

User Configuration

The following differences in the user configuration should be noted:

1. Allocation of CS memory is not required. The CTI 2500 controller uses high speed DRAM to store and execute compiled SF programs and subroutines.
2. The CTI 2500 controller does not support user subroutines (XSUB) or the allocation of User Memory.
3. A time slice for Report by Exception (RBE) is not supported. The CTI 2500 controller does not support RBE.
4. A new time slice, Network Communications, has been added to support the local Ethernet port.

I/O Support

The I/O support has the following restrictions:

1. The CTI 2500 does not support interrupt I/O.
2. Non- CTI Special Function modules may not operate properly with the CTI 2500. Before attempting to use SF modules manufactured by other vendors, see the CTI Web Site (www.controltechnology.com) or contact CTI Product Support to determine whether the module you plan on using has been certified to work with the CTI 2500.

APPENDIX E. – BATTERY REPLACEMENT

The 2500 Series controller uses a non-rechargeable lithium battery to maintain user programs and related data when AC power is removed. The battery and the battery cover are shipped in plastic bags contained in the controller shipping box.

Remove these items from the bag. Insert the battery into the battery holder with the button end (+) facing outward. Align the battery cover tabs with the slots in the holder. Press the cover in until it is flush with the holder and rotate it 90° in a clockwise direction. You can insert a coin or a screwdriver into the slot on the cover to aid in rotating the cover.



Batteries should be stored in the original shipping container in a cool well-ventilated area. Dispose of used batteries according to the instructions of its manufacturer and in compliance with all federal, state, and local regulations.

WARNING

The controller uses a 3.6V Lithium battery (non-rechargeable), size AA. See Appendix F for additional information.

Batteries must be changed in an area known to be non-hazardous.

Do not attempt to charge the lithium battery.

Charging a lithium battery can cause the battery to explode, resulting in serious injury or death and/or damage to equipment. Replace the battery as shown above.

Lithium batteries contain flammable material. Do not puncture or crush the battery case, since this can release the material and electrolyte. Exposure to electrolyte can cause eye and/or throat irritation. If the electrolyte comes into contact with your skin or eyes, flush thoroughly with water.

Do not place batteries on a metal surface, as this could cause a short circuit.

If a lithium battery short-circuits, disconnect it immediately and move it to a well-ventilated area. Wear safety glasses and other protective gear when handling a defective battery.

Do not use lithium batteries in a completely sealed container. There must be a means of relieving pressure if the battery is exposed to high temperature or abuse.

Replacement batteries may be obtained from sources other than CTI. See Appendix F for battery specifications. Batteries of the correct type that do not meet the low current specification will have a shorter continuous use life.

CAUTION

The battery used by the 2500 Series PLC is different than the one used with the CTI Janus Controller. Use of the Janus Controller battery will significantly reduce battery life.

APPENDIX F. – PRODUCT SPECIFICATIONS

Hardware Specifications

Module Size: Double Wide I/O

Backplane Power Consumption: 5.5 watts @ 5 VDC

Operating Temperature: 0° to 60° C (32° to 185° F)

Storage Temperature: -40° to 85° C (-40° to 185° F)

Humidity: 0% to 95%, non-condensing

Battery Type: 3.6V Lithium battery (non-rechargeable), size AA

Battery Capacity @ 35µA: Greater than 1.5Ah

Battery Operating Temperature: 0° to 60° C (32° to 185° F)

Typical Battery Storage Life: 5 Years (not connected)

Typical Battery Continuous Use Life: 3 years @ 25°C, 6 months @ 60°C

Serial Port Pinout

The serial port supports both the RS-232 and RS-422 electrical interface. The electrical interface in use is selected by a dipswitch setting (see Section 2.3). The cable used with the interface must connect to the correct pins used by the electrical interface. See the following pinout diagram for the serial port DB-9 connector.

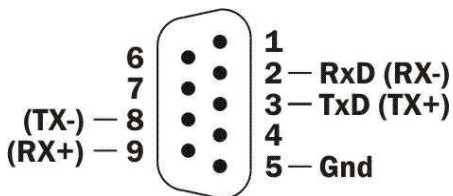

For RS -232 the following pins are used:

Pin	Signal	Description
2	RxD	Received Data
3	TxD	Transmitted Data
5	GND	Signal Ground

For RS - 422, the following pins are used:

Pin	Signal	RS-422 Signal
2	RX -	Receive Data (minus)
3	TX +	Transmit Data (plus)
5	GND	Signal Ground
8	TX -	Transmit Data (minus)
9	RX+	Receive Data (plus)

I/O Port Pinout

The figure below illustrates the pin connections of the DB-9 Remote I/O connector.

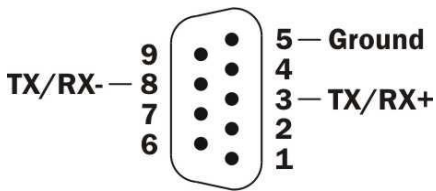

Connect the conductor without the shielding to pin 5 of the mating connector. Connect one of the color coded conductors to pin 8 and the other to pin 3. It does not matter which color you choose, except that you must be consistent throughout the remote I/O installation.

Profibus Port Pinout

The following figure illustrates the pin connections of the Profibus DP DB9 connector. The TX/RX + and TX/RX – wires are connected as shown. The cable shield is connected to Chassis Ground. Pins 5 and 6 are used for the bias circuit.

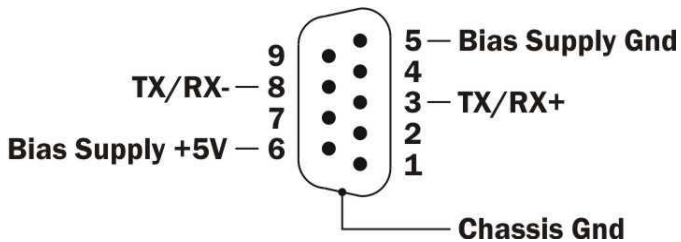

APPENDIX G. – SD CARD REQUIREMENTS

CTI 2500 Series Classic Controller SD Card Requirements

The CTI 2500 Series Classic controller (2500-Cxxx) supports full size standard capacity and high capacity (SDHC) cards. Standard Capacity full size cards are marked with the SD logo.



High Capacity full size cards SDHC logo. CTI recommends that you use an SDHC card, which is the newer design. SDXC and SDIO cards are not supported.

NOTE:

Support for SDHC cards was added in firmware version 6.18 (12/21/2011). Prior firmware versions supported only standard capacity SD cards.

CTI 2500 Series Compact Controller SD Card Requirements

The CTI 2500 Series Compact controller (2500C-Cxx) supports micro SDHC cards. Micro SDXC and micro SDIO cards are not supported.



Data Storage Capacity

SDHC and micro SDHC cards range in capacity from 4GB to 32GB (where GB represents gigabytes). The smallest capacity (4GB) is more than adequate for use with the 2500 series controller. However, you can use SDHC cards with a larger capacity, if you wish.

If you must use a standard capacity card, choose one with a capacity of 256MB- 1GB. Smaller capacity cards were produced before the specification was mature.

Physical Size

There are three sizes of SD cards: standard, mini, and micro. The SD card receptacle on the 2500 Series Classic controller (2500-Cxxx) is designed for a standard size card, which is the largest form factor. A passive adapter can be used to accommodate the smaller mini or micro sizes, if necessary. The SD card receptacle on the 2500 Series Compact controller (2500C-Cxxx) is designed for the micro SD size.

Speed

Modern SD cards indicate the access speed by a class rating, which indicates the minimum continuous write speed in MB/sec. For example, a class rating of 4 indicates an access speed of 4 MB/sec. For firmware update, the speed of the card is not important, although it will have some small effect on the time to transfer the update file to the controller.

LIMITED PRODUCT WARRANTY

Warranty. Control Technology Inc. ("CTI") warrants that this CTI Industrial Product (the "Product") shall be free from defects in material and workmanship for a period of one (1) year from the date of purchase from CTI or from an authorized CTI Industrial Distributor, as the case may be. Repaired or replacement CTI products provided under this warranty are similarly warranted for a period of 6 months from the date of shipment to the customer or the remainder of the original warranty term, whichever is longer. This Product and any repaired or replacement products will be manufactured from new and/or serviceable used parts which are equal to new in the Product. This warranty is limited to the initial purchaser of the Product from CTI or from an authorized CTI Industrial Distributor and may not be transferred or assigned.

2. Remedies. Remedies under this warranty shall be limited, at CTI's option, to the replacement or repair of this Product, or the parts thereof, only after shipment by the customer at the customer's expense to a designated CTI service location along with proof of purchase date and an associated serial number. Repair parts and replacement products furnished under this warranty will be on an exchange basis and all exchanged parts or products become the property of CTI. Should any product or part returned to CTI hereunder be found by CTI to be without defect, CTI will return such product or part to the customer. The foregoing will be the exclusive remedies for any breach of warranty or breach of contract arising therefrom.

3. General. This warranty is only available if (a) the customer provides CTI with written notice of a warranty claim within the warranty period set forth above in Section 1 and (b) CTI's examination of the Product or the parts thereof discloses that any alleged defect has not been caused by a failure to provide a suitable environment as specified in the CTI Standard Environmental Specification and applicable Product specifications, or damage caused by accident, disaster, acts of God, neglect, abuse, misuse, transportation, alterations, attachments, accessories, supplies, non-CTI parts, non-CTI repairs or activities, or to any damage whose proximate cause was utilities or utility-like services, or faulty installation or maintenance done by someone other than CTI.

4. Product Improvement. CTI reserves the right to make changes to the Product in order to improve reliability, function or design in the pursuit of providing the best possible products.

5. Exclusive Warranty. THE WARRANTIES SET FORTH HEREIN ARE CUSTOMER'S EXCLUSIVE WARRANTIES. CTI HEREBY DISCLAIMS ALL OTHER WARRANTIES, EXPRESS OR IMPLIED. WITHOUT LIMITING THE FOREGOING, CTI SPECIFICALLY DISCLAIMS THE IMPLIED WARRANTIES OF MERCHANTABILITY, FITNESS FOR A PARTICULAR PURPOSE, NON-INFRINGEMENT, COURSE OF DEALING AND USAGE OF TRADE.

6. Disclaimer and Limitation of Liability. TO THE FULLEST EXTENT PERMITTED BY APPLICABLE LAW, CTI WILL NOT BE LIABLE FOR ANY BUSINESS INTERRUPTION OR LOSS OF PROFIT, REVENUE, MATERIALS, ANTICIPATED SAVINGS, DATA, CONTRACT, GOODWILL OR THE LIKE (WHETHER DIRECT OR INDIRECT IN NATURE)

OR FOR ANY OTHER FORM OF INCIDENTAL, INDIRECT OR CONSEQUENTIAL DAMAGES OF ANY KIND. CTI'S MAXIMUM CUMULATIVE LIABILITY RELATIVE TO ALL OTHER CLAIMS AND LIABILITIES, INCLUDING OBLIGATIONS UNDER ANY INDEMNITY, WHETHER OR NOT INSURED, WILL NOT EXCEED THE COST OF THE PRODUCT(S) GIVING RISE TO THE CLAIM OR LIABILITY. CTI DISCLAIMS ALL LIABILITY RELATIVE TO GRATUITOUS INFORMATION OR ASSISTANCE PROVIDED BY, BUT NOT REQUIRED OF CTI HEREUNDER. ANY ACTION AGAINST CTI MUST BE BROUGHT WITHIN EIGHTEEN (18) MONTHS AFTER THE CAUSE OF ACTION ACCRUES. THESE DISCLAIMERS AND LIMITATIONS OF LIABILITY WILL APPLY REGARDLESS OF ANY OTHER CONTRARY PROVISION HEREOF AND REGARDLESS OF THE FORM OF ACTION, WHETHER IN CONTRACT, TORT (INCLUDING NEGLIGENCE AND STRICT LIABILITY) OR OTHERWISE, AND FURTHER WILL EXTEND TO THE BENEFIT OF CTI'S VENDORS, APPOINTED DISTRIBUTORS AND OTHER AUTHORIZED RESELLERS AS THIRD-PARTY BENEFICIARIES. EACH PROVISION HEREOF WHICH PROVIDES FOR A LIMITATION OF LIABILITY, DISCLAIMER OF WARRANTY OR CONDITION OR EXCLUSION OF DAMAGES IS SEVERABLE AND INDEPENDENT OF ANY OTHER PROVISION AND IS TO BE ENFORCED AS SUCH.

7. Adequate Remedy. The customer is limited to the remedies specified herein and shall have no others for a nonconformity in the Product. The customer agrees that these remedies provide the customer with a minimum adequate remedy and are its exclusive remedies, whether based on contract, warranty, tort (including negligence), strict liability, indemnity, or any other legal theory, and whether arising out of warranties, representations, instructions, installations, or non-conformities from any cause. The customer further acknowledges that the purchase price of the Product reflects these warranty terms and remedies.

8. Force Majeure. CTI will not be liable for any loss, damage or delay arising out of its failure (or that of its subcontractors) to perform hereunder due to causes beyond its reasonable control, including without limitation, acts of God, acts or omissions of the customer, acts of civil or military authority, fires, strikes, floods, epidemics, quarantine restrictions, war, riots, acts of terrorism, delays in transportation, or transportation embargoes. In the event of such delay, CTI's performance date(s) will be extended for such length of time as may be reasonably necessary to compensate for the delay.

9. Governing Law. The laws of the State of Tennessee shall govern the validity, interpretation and enforcement of this warranty, without regard to its conflicts of law principles. The application of the United Nations Convention on Contracts for the International Sale of Goods shall be excluded.

REPAIR POLICY

In the event that the Product should fail during or after the warranty period, a Return Material Authorization (RMA) number can be requested orally or in writing from CTI main offices. Whether this equipment is in or out of warranty, providing a Purchase Order number provided to CTI when requesting the RMA number will aid in expediting the repair process. The RMA number that is issued and your Purchase Order number should be referenced on the returning equipment's shipping documentation. Additionally, if the product is under warranty, proof of purchase date and serial number must accompany the returned equipment. The current repair and/or exchange rates can be obtained by contacting CTI's main office at 1-800-537-8398 or go to www.controltechnology.com/support/repairs/.

When returning any module to CTI, follow proper static control precautions. Keep the module away from polyethylene products, polystyrene products and all other static producing materials. Packing the module in its original conductive bag is the preferred way to control static problems during shipment. Failure to observe static control precautions may void the warranty.