

CTI 2500P-JACP

Janus Application Coprocessor

Installation and Operation Guide

Version 1.2

**Copyright 2022 Control Technology Inc.
All rights reserved.**

This manual is published by Control Technology Inc. (CTI) 5734 Middlebrook Pike, Knoxville, TN 37921. This manual contains references to brand and product names which are trade names, trademarks, and/or registered trademarks of Control Technology Inc. Siemens® and Series 505® are registered trademarks of Siemens AG. Other references to brand and product names are trade names, trademarks, and/or registered trademarks of their respective holders.

DOCUMENT DISCLAIMER STATEMENT

Every effort has been made to ensure the accuracy of this document; however, errors do occasionally occur. CTI provides this document on an “as is” basis and assumes no responsibility for direct or consequential damages resulting from the use of this document. This document is provided without express or implied warranty of any kind, including but not limited to the warranties of merchantability or fitness for a particular purpose. This document and the products it references are subject to change without notice. If you have a comment or discover an error, please call us at 1-800-537-8398 or email us at sales@controltechnology.com.

REVISION HISTORY

V1.0	2/15/2023	Initial Release
V1.1	4/19/2023	Added product specification matrix from product bulletin and added clarifying description about "max connections".
V1.2	8/10/2023	Added potential use case configurations and information regarding remote base installation.

PREFACE

This ***Installation and Operation Guide (IOG)*** provides information regarding installation, setup, and operation of the *CTI Janus Application Coprocessor*, also referred to as the *JACP module* in this manual.

This document is not intended to serve as a programming reference for application development. A comprehensive and thorough programming reference for application development is provided by the ***Janus Workbench*** online help system. This online help is critical for gaining an initial understanding of the product and is intended to be used as a reference for various aspects of the products features. The online help search feature provides for a quick way locate targeted information.

USAGE CONVENTIONS

NOTE

Notes alert the user to special features or procedures.

CAUTION

Cautions alert the user to procedures that could damage equipment.

WARNING

Warnings alert the user to procedures that could damage equipment and endanger the user.

TABLE OF CONTENTS

PREFACE	4
USAGE CONVENTIONS	5
TABLE OF CONTENTS	7
CHAPTER 1 INTRODUCTION	10
1.1 Janus Application Coprocessor Overview	10
1.2 Janus Programming Software.....	12
CHAPTER 2 FRONT PANEL	15
2.1 JACP Module Front Panel.....	15
2.2 Status Indicator LEDs.....	16
2.3 Alphanumeric Display.....	16
2.4 Reset Pushbutton	16
2.5 Ethernet Communications Ports	17
2.6 Serial Ports	18
CHAPTER 3 INSTALLATION	19
3.1 Installation Planning.....	19
3.1.1 <i>Choosing the IP Address and related Parameters</i>	19
3.1.2 <i>Power Requirements</i>	19
3.2 Installing the Module.....	19
3.2.1 <i>Unpacking the Module</i>	19
3.2.2 <i>SD Card Installation</i>	20
3.2.3 <i>Setting the Module Switches</i>	21
3.2.4 <i>Physical Installation</i>	21
3.2.5 <i>Applying Power to the Base</i>	22
3.2.6 <i>Connecting the Module to a Data Network</i>	22
3.2.7 <i>Startup from Factory Defaults</i>	22
3.2.8 <i>Setting the IP Address</i>	22
CHAPTER 4 CONFIGURATION	25
4.1 General Settings	25
4.2 Network Settings.....	26
4.2.1 <i>IP Parameters</i>	26
4.2.2 <i>DNS Configuration</i>	26
4.2.3 <i>Internal Ethernet Switch Configuration</i>	26
4.3 Security Settings.....	27
4.4 Clock Settings.....	28
CHAPTER 5 OPERATION	29
5.1 JACP Module Operation Overview	29
5.2 Module Startup	30
5.3 Reset Pushbutton Operation.....	31
5.4 HTTP Data Server	32

CHAPTER 6 UPDATING FIRMWARE	33
6.1 Overview	33
6.2 User SD Card Firmware Update	33
6.3 Remote Firmware Update	34
6.4 Direct File Replacement	35
CHAPTER 7 EMBEDDED WEB SERVER	36
7.1 Product Information	36
7.2 Application Information	37
7.3 Configuration.....	37
7.3.1 <i>General Settings</i>	37
7.3.2 <i>Network Settings</i>	38
7.3.3 <i>Security Settings</i>	38
7.3.4 <i>Clock Settings</i>	39
7.3.5 <i>File Management</i>	40
7.3.6 <i>Firmware Update</i>	41
7.3.7 <i>Product Reset</i>	41
7.4 Event Log	42
7.5 Statistics.....	43
7.6 Error Descriptions and Status	43
7.7 Display All Pages	43
7.8 Custom HTML (graphics)	44
7.9 Acknowledgements	44
7.10 Product Support.....	44
APPENDIX A: SYSTEM ERROR CODES	45
CPU Startup Errors	45
Module Run Mode Startup Errors	46
Firmware/Configuration Update Errors.....	47
Execution Errors	47
SD Card Errors	48
Client Communication Errors.....	48
Hardware Errors	51
APPENDIX B: IP ADDRESS INFORMATION	52
IP Address Nomenclature	52
Using the Subnet Mask	54
CIDR Notation.....	55
Selecting an IP Address	55
Selecting a Multicast Address.....	56
APPENDIX C: ETHERNET PORT OPERATION	57
Ethernet Port Operation	57
Alternate IP Subnets	58
APPENDIX D: SERIAL PORT WIRING	60
RS232 Wiring.....	60
RS422 Wiring.....	61
RS485 Wiring.....	62
APPENDIX E: PRODUCT SPECIFICATIONS	63
Environmental Specifications	63
Agency Approvals (pending).....	63
Functional Specifications	64

LIMITED PRODUCT WARRANTY	66
REPAIR POLICY	68

CHAPTER 1 INTRODUCTION

1.1 Janus Application Coprocessor Overview

The CTI Janus Application Coprocessor (JACP) module augments the communications capability of CTI Janus Controllers and CTI 2500 Series controllers. It also enables Siemens Series 505[®] controllers to communicate using modern Ethernet protocols, such as Ethernet/IP and OPCUA. In some applications, it can function as a standalone controller, using Ethernet IO protocols, such as Ethernet/IP scanner and Modbus Client drivers.

The JACP module can be used in the following configurations:

- The module can be used as a co-processor and share data with a Siemens or Texas Instruments 505 PLC using the block transfer driver,
- The module can be used as a co-processor and share data with a CTI 2500 PLC using data cache or block transfer driver,
- The module can be used as a co-processor and share data with a CTI Janus PLC using the binding protocol,
- The module can be used in a standalone control situation and not have the need to share data with any other PLC.

The JACP module can be installed in a local or remote base. When installed in a remote base with a standard Remote Base Controller (RBC), the performance of the Block Transfer driver, if used, will likely be degraded. When installed in a remote base with a Profibus RBC, the Block Transfer driver will not work, since the Profibus RBC does not support SFIO.

Flexible Programming Support

The JACP module allows you to program in languages that best fit your application requirements and your programming expertise. The following IEC 61131-3 compliant languages are supported:

- Relay Ladder Logic (RLL)
- Function Block Diagram (FBD)
- Structured Text (ST)
- Sequential Function Chart (SFC)

A single project can contain programs written in different languages. Programs written in one language can be easily translated to another language to help with long term application support.

Integrated Ethernet Communications

The module provides two isolated Ethernet ports, which can operate independently of each other. They can be used to provide redundant network paths or to connect to different Ethernet networks. Since the module can be configured with two IP addresses, it can communicate concurrently on two different IP networks.

Ethernet Data Communications Protocols,

The module supports the following data communications protocols:

- CAMP Client (used to communicate with CTI 2500 Series CPUs and Ethernet modules)
- CAMP Server (allows data access from HMI/SCADA workstations using CAMP Client drivers)
- CTI Enhanced Data Cache Client (optimized interface to CTI 2500 Series Controllers)
- Block Transfer (enables communications with Series 505 controllers using the Special Function I/O protocol)

- Ethernet I/P Tag Client (used to communicate with Rockwell Logix controllers)
- Ethernet I/P Server (allows data access from HMI/SCADA workstations using Tag Client drivers)
- MQTT Client (support for IIOT (Industrial Internet of Things))
- OPCUA Server (Provides data access services to any product that supports an OPCUA client)
- Custom TCP/UDP client and server applications using network socket management functions
- Network Data Exchange (binding)

Ethernet I/O Protocols

The module supports:

- Open Modbus Client (TCP or UDP)
- Open Modbus Server (TCP or UDP)
- Ethernet I/P Scanner (supports Implicit I/O messages and CIP Explicit messages)
- Ethernet I/P Adapter (provides an interface for EIP I/O Scanners and CIP Explicit Message Clients).
- Ethernet/IP Flex IO Client

Serial Protocols

The module provides two serial ports. Each port can be configured for RS-232, RS-422, or RS-485 electrical interfaces. The serial ports can be used for the following communications protocols:

- Modbus RTU Master – Allows the module to function as a Modbus RTU Master
- Modbus RTU Slave – Allows the module to function as a Modbus RTU Slave
- General ASCII – Allows the module to send and receive ASCII Characters

Web Server Interface

The module contains an embedded web server, which provides an interface to detailed information regarding the controller configuration, operation, and history. The web server can be used to:

- Obtain information about the product and application
- Configure the product settings
- Update product firmware
- Perform file transfer operations
- Access user-generated graphics pages (monitor and control application)
- View diagnostic information (such as error and status info)
- Access operational statistics
- View Event Log
- Supports user created web pages that access controller application data. (See Section [5.4](#) HTTP Data Server).

The web server can be accessed by entering the controller IP address in the URL box of your browser.

Online Change Support

The module supports a comprehensive change facility that allows you to make extensive changes to the user program, then download the changed program without bumping the I/O. See the *Janus Workbench Help* for detailed information and limitations.

Security

The module supports the following set of security features:

- “Secure Boot” process – encryption keys that verify the controller is running an authenticated CTI version of the firmware;
- Password protection for accessing JACP module from Janus Workbench (set via Workbench);
- Password protection for modifying and/or viewing any POU from Janus Workbench (set via Workbench);
- Password protection for modifying module Configuration settings via web server (Includes File Management and Firmware Update operations);
- Password protection for the controller Operation pages (File Management/Firmware Update);
- Password protection for accessing visualization (HTML5 Graphics);
- User program is compiled on the PC and downloaded, which allows more user options for controlling access to the project source files;
- Certificate-based security for OPCUA message signing and encryption.

Compatibility

The JACP module is designed to work in the same plant environment as the CTI 2500 Series PLC and the CTI Janus Controllers. It uses the same programming software as the CTI Janus Controllers. It can function as an Ethernet CAMP server, allowing it to communicate with existing HMI/SCADA workstations and CTI 2572/2572-A/2572-B communications modules. It can also act as a CAMP client for peer-to-peer communications to existing CTI products. The Enhanced Data Cache Client protocol facilitates high speed communications with CTI 2500 Series PLCs. The Block Transfer protocol enables communications with Siemens Series 505 controllers using the Special Function IO protocol.

High Performance

The JACP Module is powered by a high performance SoC (System on Chip) with ARM®+ FPGA architecture providing considerable I/O bandwidth with low system power requirements. This architecture provides capability to simultaneously execute logic and I/O communications which translates to sub-millisecond cycle times for many small applications.

1.2 Janus Programming Software

The JACP module is programmed using *Janus Workbench*. Janus Workbench is a full-featured Integrated Development Environment (IDE) tool that includes a configuration tool, programming editor, debugger, data monitor, and simulator. The application program may be developed in any of four IEC-61131 programming languages. A complete library of functions is provided to perform the following tasks:

- Complex mathematical computations
- Boolean logic
- Data conversion
- String handling
- Timer/Counter operations
- PID control
- Alarm monitoring
- Data Logging and file access functions
- Protocol driver management
- Integrated version control.

The programming architecture enables the “building block” approach to application design which encourages the re-use of well-documented and proven code sections. Custom logic using complex data types such as structures and enumerations can be embedded into Sub-Programs and User Defined Function Blocks (UDFBs) and re-used in multiple applications.

Janus Workbench also provides a means to select and configure fieldbus drivers supported by the module. For more information, refer to the Janus Workbench Help system.

CHAPTER 2 FRONT PANEL

2.1 JACP Module Front Panel

- 1. Operational Status LEDs**
CPU GOOD
RUN
ERROR
- 2. Alphanumeric Display**
- 3. Reset Button**
- 4. Ethernet Port 1 (1000 Mb)**
Link LED (LINK)
Activity LED (ACT)
- 5. Ethernet Port 2 (1000 Mb)**
Link LED (LINK)
Activity LED (ACT)
- 6. Transmit and Receive LEDs – Serial Port 1**
- 7. Serial Port 1 (Top Six Pins)**
- 8. Serial Port 2 (Bottom Six Pins)**
- 9. Transmit and Receive LEDs – Serial Port 2**

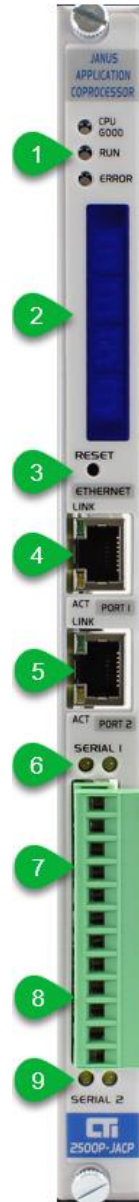

2.2 Status Indicator LEDs

LED	Color	State	Indication
CPU GOOD	BLUE	Off	Not operational – module initialization failure or no power
		Flash	N/A
		On	Module hardware/firmware passed all power-on tests and operation is normal
RUN	BLUE	Off	Application program stopped or not loaded
		Flash	Program loaded but logic is not running (LOGIC STOP state). I/O interface and communication protocols are active.
		On	Application program is executing (RUN state)
ERROR	YELLOW	Off	No active errors
		Flash	Critical error that prevents application from entering RUN mode (Error Code displayed on front panel display)
		On	After software boot, indicates active error conditions. These errors can occur while in RUN mode and will not prevent application from transferring to RUN mode. (Error Code displayed on front panel display) On initial power up, this signals that the hardware is powered and ready for software boot.

2.3 Alphanumeric Display

The Alphanumeric Display is used to display IP parameters (i.e., IP addresses and subnet information) and active error status information. If desired, the display of IP parameters can be disabled using the embedded web server. When an error state is active, the corresponding error code is displayed. When multiple error states are active, the highest priority active error code is displayed. See [APPENDIX A SYSTEM ERROR CODES](#) for a list of system error codes and descriptions.

2.4 Reset Pushbutton

When enabled, the **RESET** pushbutton provides a direct method to clear exceptions, reset module configuration values to default values, or restore factory defaults without requiring access to *Janus Workbench* or the module web server. See [Section 5.3](#) for more information.

NOTE

*The recessed pushbutton will function only when Switch 3 is in the CLOSED position.
See Section 3.4 Setting the Module Switches*

2.5 Ethernet Communications Ports

The RJ-45 Ethernet ports, labeled **PORT 1 AND PORT 2**, are identical in their operation and usage. Both ports are capable of operating at 1000Mb (1Gb) full duplex. If connected to a device that does not support the maximum port speed, a port will auto-negotiate with the device a slower speed (100Mb or 10Mb). Both ports can be used for multiple purposes, such as programming and monitoring, data communications with SCADA workstations and other devices, and Ethernet based I/O. Duplicate IP Address detection, broadcast/multicast storm protection and traffic rate limiting are enabled for each port.

By default, Ethernet frames arriving at a port are forwarded only to the controller microprocessor. Ethernet frames are not forwarded between the ports, preventing the accidental creation of loops. If ports are connected to different networks, this behavior prevents traffic on a particular network from entering the other networks. To allow for special situations, forwarding between ports can be enabled in the web server CONFIGURATION/NETWORK SETTINGS page. See [Section 4.2.3 Internal Ethernet Switch Configuration](#).

Each Ethernet port connector contains two embedded LEDs. The **LINK** LED (top) indicates whether the Ethernet port is successfully connected to another Ethernet device, such as a network switch. The **ACTIVITY** LED (bottom) provides visual indication that Ethernet packets are being received or transmitted via the port. See the following table below for details.

LED	State	Indication
Link	Off	Ethernet link is not established (unconnected)
	On	Ethernet link is established (connected)
Act (Activity)	Off	No Ethernet frames are being transmitted on the network to which the port is connected.
	On (Blinking)	Ethernet frames are being transmitted on the network to which the port is connected

2.6 Serial Ports

The front panel 12-pin plug connector provides the interface to both serial ports. This connector replaces the DB9 Male D-Sub connector used for serial port connections in most legacy devices. The plug connector provides user-friendly terminals that do not require soldering, and wiring connections can be easily verified and/or changed as necessary.

The top six pins are connections for **Serial Port 1** and the bottom six pins are used for connection to **Serial Port 2**.

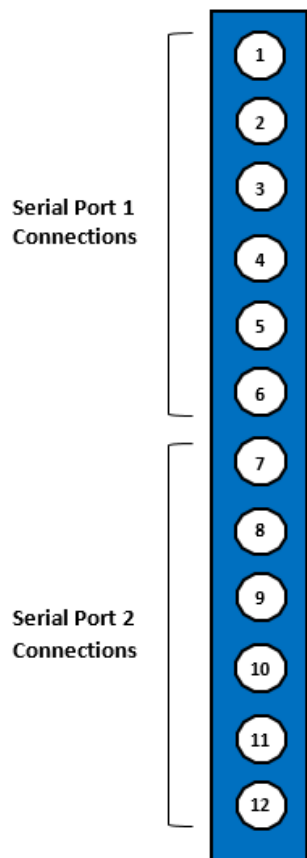

The pin-out (i.e. function for each serial port terminal) varies according to the specified electrical interface (RS232, RS422, or RS485). See APPENDIX D: Serial Port Wiring for the pin-out for each electrical interface.

CHAPTER 3 INSTALLATION

This section discusses the items to consider while planning the JACP module installation and the actual steps for installation of the module.

3.1 Installation Planning

3.1.1 Choosing the IP Address and related Parameters

Before you can use the Ethernet ports, the controller must be configured with network parameters for the Primary IP subnet, including IP address, network mask, and the default gateway. The module also allows you to set the IP parameters for a second Alternate subnet if you wish (see [Appendix C Ethernet Port Operation](#)) for more information). If you already have a network installed, you should contact your network administrator to determine the values to be used. See APPENDIX B: IP ADDRESS INFORMATION for more information on choosing an IP address. See [Section 3.2.8](#) and for information on setting the network parameters.

3.1.2 Power Requirements

The JACP module consumes 7 watts of +5 VDC power. To calculate the total power required for the base, you need to add the power requirements for the controller and other modules you will install in the base.

3.2 Installing the Module

3.2.1 Unpacking the Module

Open the shipping carton and remove the special anti-static bag that contains the module. Ensure you are properly grounded and have discharged any static buildup before removing the unit from the static bag.

Do not discard the anti-static bag; use it for protection against static damage when the module is not inserted into the I/O base.

CAUTION

The components on the JACP module printed circuit card can be damaged by static electricity discharge. To prevent this damage, the module is shipped in a special anti-static bag. Static control precautions should be followed when removing the module from the bag and when handling the printed circuit card during configuration.

3.2.2 SD Card Installation

The JACP module uses a Secure Data High Capacity (SDHC) card to store configuration data, executable program, application program source files, and user data files. This card is pre-installed in the System SD card receptacle on all units shipped from the factory. Contact CTI support if the SD card is missing. If you need to replace the System SD card, an SDHC card with a class rating of  is required. CTI recommends you purchase an SD card with an industrial rating. A capacity of 16GB is usually sufficient.

Because all configuration and operational files are contained on the System SD card, the complete module profile can be transferred to another unit simply by swapping SD cards.

To remove and replace the System SD card:

- Remove power to the base.
- Remove the controller from the base.
- To remove the card, apply insertion pressure until you hear a click, then release pressure.
- To install the card, insert the card in the receptacle face up, with the beveled edge facing the receptacle. Continue insertion until you hear a click

Some operations require a second (User) SD card. When required, insert an SDHC card in the User SD Card receptacle. For this card, an SDHC card with class rating of  is usually sufficient.

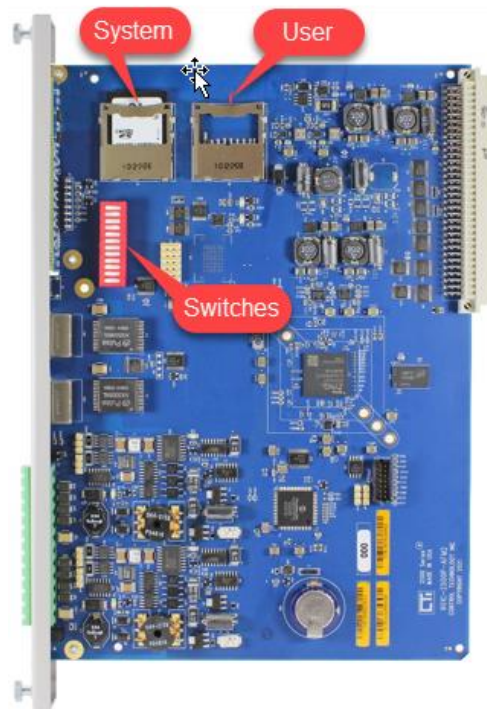

3.2.3 Setting the Module Switches

The location of the module switches is shown above. See the following table for information about the switch functions.

Switch Position	Use	Open Position	Closed Position
1	Remote Firmware Update	Disabled	Enables firmware update via web server. See Section 6.3 for details.
2	SD Card Firmware Update	Normal operation	Controller enters <i>User SD Card Firmware Update</i> mode at startup. See Section 6.2 for details.
3	Clear Exception Pushbutton	Disabled	Enables the recessed pushbutton to be used to clear exceptions, configuration reset, or to restore factory settings. See Section 5.3 .
4	SD Card Ethernet Port Setup	Disabled	Allows user to configure controller Ethernet Port 1 via User SD Card. NOTE: This setting works <u>ONLY</u> if Switch 2 is OPEN. See Section 3.2.8 .
5	Remote Controller Reset	Disabled	Enables the ability to clear exceptions, Configuration Reset, and Restore Factory Settings using the embedded web server.
6 - 12	Reserved		

3.2.4 Physical Installation

Before installing the module, remove AC power from the rack. Align the circuit board with the connector. Slide the module into the rack until the connector seats. Then use the thumbscrews to secure the controller in the rack.



WARNING

Do not install or remove the module while line power is applied. It can damage the module or other equipment and could cause injury or death.

3.2.5 Applying Power to the Base

Apply AC power to the base power supply. The CPU GOOD LED on the module should illuminate, indicating that power is being supplied to the base connector. The JACP module should power up. See [Section 5.2 Module Startup](#) for additional information.

3.2.6 Connecting the Module to a Data Network

To connect the JACP module to an Ethernet network, insert an Ethernet cable that is rated Category 5e into the RJ-45 connector of either front panel Ethernet port: PORT 1, or PORT 2. Insert the other end into the RJ-45 connector of the network Ethernet switch. If the connection is successful, the Link LED on the RJ-45 connector will illuminate.

3.2.7 Startup from Factory Defaults

If you are starting up using the factory default, the module will attempt to obtain an IP address using DHCP (Dynamic Host Configuration Protocol). If a valid response is received, the module will use the IP address parameters provided. If not, the module will assign an IP address from the Link Local IPV4 range.

IP Address in IPV4 link-local address block: 169.254.0.0 – 169.254.255.255

Subnet Mask: 255.255.0.0 (CIDR 16)

Gateway Address: 0.0.0.0

NOTE

The IP address parameters obtained from DHCP or assigned from the link local range are for temporary use only. They are not permanently stored and will be cleared when the module is restarted. You can set a permanent IP address by using this address to access the web server configuration page or you can use the SD Card Ethernet Port setup described below.

3.2.8 Setting the IP Address

SD Card Ethernet Port Setup

The **SD Card Ethernet Port Setup** procedure provides an alternate method to specify a fixed IP Address for the module Primary Subnet configuration when the web server is not accessible. This is useful for setting the initial IP address for a new product or following a configuration reset.

This operation executes only if Module Switch 2 is OPEN and Module Switch 4 is CLOSED. If both Switches 2 and 4 are CLOSED, the 'User SD Card Firmware Update' operation, which is executed when Switch 2 is CLOSED takes precedence.

This operation requires the following steps:

- a) Create a file named 'cti.ini' using your favorite text editor (Notepad works just fine).

The following keywords and associated values must be inserted into this file. The values must be valid network settings expressed in dotted decimal notation. WARNING: Do not use leading zeroes for any of the 4 octets in any of the IP addresses, as leading zeroes in TCP/IP will imply base-8 notation (Don't use: 192.168.001.011, Instead use: 192.168.1.11).

```
[NET0]
usingdhcp = false
ip = x.x.x.x
subnetmask = x.x.x.0
gateway = x.x.x.x *
```

* This keyword and associated value are optional. If you don't want to specify a default gateway address, you should omit this entry.

Examples:

With Gateway Address:

```
[NET0]
usingdhcp = false
ip = 198.18.74.56
subnetmask = 255.255.255.0
gateway = 198.18.74.1
```

Without Gateway Address:

```
[NET0]
usingdhcp = false
ip = 198.18.74.56
subnetmask = 255.255.255.0
```

Each keyword/value combination must be entered on a separate line. If keywords are duplicated, only the first entry is processed – the others are ignored.

- b) Copy the cti.ini file created above to the root directory of a SD card. The file system of the user SD card should be either FAT32 or EXFAT. This is the way they come when newly purchased. If you have reformatted your SD card with the NTFS file system, or any other file systems, it will not work.
- c) Turn off power to the base, remove the module from the base, set Module Switch 4 to CLOSED position (and ensure Module Switch 2 is OPEN) and insert that card into the User SD Card receptacle on the JACP PC board. Re-install the module into the base, and restore power.
- d) On power up, the module enters **Port Parameter Setup** mode and displays **PPSt** on the front panel display. While in this mode, the web server can be accessed using the currently active IP address. However, the module will not accept connections from **Janus Workbench**.
- e) Next, the module will attempt to find the 'cti.ini' configuration file in the root directory of the User SD card.
 - If cti.ini file is found, the file is then validated to ensure all the required data is included and correct.
 - If the required keywords are found and validated, the procedure continues at step h below.
- f) If any of the following errors occur, **PPEr** is displayed for 5 seconds indicating a **Port Parameterization Error** and the appropriate error (see below) is generated.
 - If a properly formatted SD card is not inserted into the User SD Card receptacle: Error 370 (**User SD Card Not Accessible**) is reported.
 - If the cti.ini file cannot be found in the SD card root folder: Error 250 (**User SD Card – Update File Not Found**) is reported.
 - If the cti.ini file does not contain the required keywords/values: Error 260 (**User SD Card - Invalid Update File**) is reported.
- g) If an error is encountered, the procedure will stop. After correcting the problem, you must re-power the module.
- h) If the operation successfully completes, the parameterization data is saved for the next module startup, the cti.ini file on the User SD card is renamed cti.bak, and **PPdn** indicating **Port Parameterization Done** is displayed on the front panel.
- i) To return to normal operation, turn off power to the base, remove the module from the base, set Module Switch 4 to the OPEN position, remove the SD card from the User SD receptacle (optional), re-install the module into the base, and restore power.
- j) On power up, the firmware performs subnet validation on the saved values. If they pass, those values are written into system parameter data. A 'Changed Network Settings' event is generated in the Event Log.

Web Server IP Address Configuration

Once your PC and the module are on the same subnet, you can configure the IP address via the embedded web server.

- Access the embedded web server by typing the IP address of the module into the URL box of your browser and pressing the ENTER key.
- Navigate to the CONFIGURATION/NETWORK SETTINGS page.
- Ensure the STATIC button is selected.
- For the Primary IP Subnet configuration, enter the parameters for the IPV4 Address, Subnet Mask, and Default Gateway
- Click on the APPLY button to accept the entries and initiate the update.

After the update is complete, the connection will be lost. To re-access the server, you will need to enter the new IP address in the browser URL box.

For additional details regarding network settings, see [Section 4.2](#).

Other Module Configuration Options

You may also use the embedded web server to configure other module characteristics, including:

- **Startup and Alphanumeric Display Options** - See [Section 4.1 General Settings](#).
- **Authentication and Encryption Options** – See [Section 4.3 Security Settings](#),
- **Clock Setting or Time Synchronization Method** – See [Section 4.4 Clock Settings](#).

CHAPTER 4 CONFIGURATION

The following parameters can be configured via the embedded web server:

4.1 General Settings

Navigate to the CONFIGURATION/GENERAL SETTINGS web page.

Module Identifier:

This is an optional text field that identifies the particular module. If Enhanced Data Cache is configured, this name will be displayed in the CTI 2500 Series PLC Host controller scan statistics.

Operation following Module Reset:

This selection determines how the application program will execute on startup following a power cycle.

- **Restore Last State (Default):** If startup state is *Restore Last State*, the project startup state is dependent on operational state when the controller was reset.
 - If the operational state was APPLICATION STOP, the project will start in APPLICATION STOP state.
 - If the operational state was RUN, the project will start in RUN state with *Warm Start* initialization.
 - If the operational state was ERROR, the project will start in APPLICATION STOP state.
- **Application Stop:** Starts with all logic programs and fieldbus drivers stopped
- **Auto-Run Cold Start:** Starts application in RUN mode with all variables set to their initialization value
- **Auto-Run Warm Start:** Starts in RUN mode with RETAIN variables are set to their last value and all other variables are set to their initialization value

NOTE: On startup following reset caused by pressing the front panel 'Reset' button, the application program state is always set to 'RUNNING – Cold Start' unless the PLC Configuration for 'Operation following Reset' is set to 'Application Stop'.

Operation following Project Download from Workbench:

- **Application Stop:** All logic programs and fieldbus drivers are stopped
- **Logic Stop:** All logic programs are stopped, fieldbus drivers execute (default)
- **Run:** Application set to RUN mode – all logic programs and fieldbus drivers execute

Front Panel Display Items:

- Check box to Display Primary Network IP address on front Panel (default is Enabled)
- Check box to display configured Alternate Subnet IP addresses on front panel (default is Enabled)
- Check Box to always Display Auto-IP address on Front Panel (default is disabled)

Click on the APPLY button to apply settings. A confirmation message should be displayed indicating that the parameters have been updated. New parameters will go into effect immediately

NOTE

The "Display Alternate subnet IP addresses" option is available only when "Display Primary Network IP" is enabled.

4.2 Network Settings

Navigate to the [CONFIGURATION/NETWORK SETTINGS](#) web page. This page allows you to set the following parameters.

4.2.1 IP Parameters

The [NETWORK SETTINGS](#) page allows you to configure the Primary subnet and an optional Alternate Subnet. The Alternate Subnet allows the module to communicate on a second IP subnet. The Alternate subnet cannot overlap the Primary subnet.

The Primary subnet IP parameters can be automatically obtained by DHCP (Dynamic Host Configuration Protocol) or statically configured by entering the IP parameters. DHCP is not recommended for operational use, since it is possible to receive different IP addresses from DHCP over time. The Alternate subnet must be statically configured. See Alternate IP Subnets in [APPENDIX C](#) for more information.

4.2.2 DNS Configuration

It is possible to use DNS (Domain Name Service) to access a device (IP host) by name instead of IP address. This will usually require coordination with your IT department to obtain the IP addresses of the Preferred and Secondary (backup) DNS servers and the Domain Suffix.

If you want others to communicate with this module by name, you will need to have a DNS entry in the DNS server for it. Similarly, any device you want to communicate with by name must have an entry in the DNS server. The IP addresses of the DNS servers can be automatically read from the DHCP server or manually entered.

4.2.3 Internal Ethernet Switch Configuration

By default, the Ethernet ports on the JACP module are isolated from each other. Ethernet frames arriving at one port are not forwarded to the other external (front panel) Ethernet port. Frames are forwarded only between an external port and the module microprocessor. This configuration protects against accidentally creating loops that can occur when there are multiple connections between two network switches. When connected to different Ethernet networks, port isolation prevents traffic on one network from entering the other network. See Ethernet Port Operation in [APPENDIX C](#) for more information.

Since there may be some applications that require forwarding between networks, you can choose an option in the web page that allows forwarding.

4.3 Security Settings

Navigate to the CONFIGURATION/SECURITY SETTINGS web page

HTTP Basic Authentication:

- **No Authentication Required (default):** Select this method to allow free access to the web server and disable password access protection.
- **Allow only the following users:** This option enables password access protection to the web server. After selecting this option, you may enter a list of usernames and passwords. The following rules apply:
 - Password list may contain up to 16 entries.
 - Username can consist of 1 -16 characters and must be unique.
 - Password may consist of 1-16 characters.
 - The following characters may be used in a password:
a-z A-Z 0-9, ~ @ % ^ _ + = { } [] : , . ? /
 - The following characters are excluded:
\$ & * () - \ | ; ' " < >

NOTE

If enabled, password entry is required to access any CONFIGURATION or CUSTOM HTML (GRAPHICS) page. Once the password is authenticated, the user can access all web pages without re-entering the password until the web browser is closed.

NOTE

If the passwords are forgotten, there is not an administrative (backdoor) method of discovering them. You need to clear all passwords by resetting the configuration settings. See [Section 5.3](#).

HTTPS Encryption

Check this box if you wish to encrypt the transmission between the browser and the web server. The Secure SSL (Secure Sockets Layer) protocol, supported by all modern browsers, is used to connect to the web page. This protocol encrypts all data transmitted between the PC browser and JACP module including username and password data required to make the connection.

When using HTTPS encryption, the user must accept a security exception the first time a web browser attempts to connect to the web server. This is required because trusted SSL certificates cannot be issued for hosts with changeable IP addresses – as is the case with the JACP module.

Click on the **APPLY** button to apply settings. A confirmation message should be displayed indicating that the module must be reset in order to update the configuration parameters. You must acknowledge this message to continue.

4.4 Clock Settings

Navigate to the CONFIGURATION/ CLOCK SETTINGS web page

Set or Synch Time Method:

- **Set Current Time:** Sets clock via manual entry of the time and date and/or use of JACP_SET_RTC function block in a logic program
- **Use Remote NTP Server:** Obtains the time from an NTP (Network Time Protocol) server.
- **Use Data Cache Client Host:** Sets clock with time read from the CTI 2500 Series Host PLC – requires use of the Enhanced Data Cache fieldbus protocol.
- **Use Block Transfer Host:** Sets clock with time read from the Siemens 505 Series PLC using SFIO

Date / Time: If manually setting the time, you should enter the time and date in these boxes.

The following entries are required only when **Use Remote NTP Server** is selected:

- **Time Zone Region:** Select the region of the time zone.
For example, in the U.S you would select “Americas”.
- **Time Zone Cities:** Select a city or area in your time zone.
For example, in the Eastern Time zone, you might select New York.
- **IP Address:** Enter IP Address of the network device acting as NTP Server

Click on the **APPLY** button to update settings. An error message will be displayed if there is a problem with your entries. Otherwise, a confirmation message will be displayed indicating that the parameters have been updated. New parameters will go into effect immediately.

CHAPTER 5 OPERATION

This section describes aspects of the JACP module operation. Additional information may be found in the *Janus Workbench* Help.

5.1 JACP Module Operation Overview

1. The JACP module can have the following operational states:
 - **APPLICATION STOP:** Application is halted. All fieldbus protocols and logic are stopped.
 - **RUN (*Janus Workbench* displays “RUNNING”):** All facets of the application operation are active - all configured fieldbus protocols and logic program are executing.
 - **LOGIC STOP:** Application is active. Logic processing is stopped and controlled via the debug “step” operations. Fieldbus protocols are running and the data base is updated.
 - **ERROR:** Application is halted. All fieldbus drivers are stopped. The module must be rebooted or operation mode changed to **Application Stop** before it can return to RUN state. Alternatively, you can use the **CLEAR EXCEPTION** button (if enabled) to exit **ERROR** state. See [Section 2.4 RESET Pushbutton](#).
2. *Janus Workbench* can be used to transfer module operation from **APPLICATION STOP** to **RUN** mode with the following initialization states:
 - **Cold Start:** All variables are set to their initialization values.
 - **Warm Start:** RETAIN variables are set to their last values, and all other variables are set to their initialization values.

Warm Start option is not available immediately after an application is downloaded from *Janus Workbench* to the module.
3. Module programs can be compiled for *Debug* or *Release* operation.
 - **Debug:** Allows remote debugging of the application program while executing on the target. This includes use of breakpoints, trace points, cycle-to-cycle debug, and step-by-step debug operations.
 - **Release:** Version compiled for faster execution without support for debugging operations. *Release* version will typically execute approximately 10% faster than the corresponding *Debug* version.
4. **RETAIN** variables are special designated Global variables whose latest value is saved to the System SD card at the end of every scan cycle. **NOTE:** *The limit for RETAIN variables is 12,232 bytes.* This provides following user options:
 - Stored values can be used as “initialization values” for specified variables when application is started using the **Warm Start** option.
 - You can save or restore values of all **RETAIN** variables on demand thru the use of the F_SAVERETAIN and F_LOADRETAIN function blocks.
5. All user data files created by user logic programs will be stored on the System SD card in the /ctiplc/user folder. To access them externally, the user must manually transfer these files to the SD card in the User SD Card receptacle on the PC board using the FILE MANAGEMENT web page.

6. When a project is downloaded from CTI Workbench while the run-time is stopped, that project is stored on the System SD card as the “active” application. All project source files are downloaded with the program, and they are also copied to the appropriate folder on the System SD card. The previous program and source files (if they exist) are renamed and saved. Any older versions are overwritten. **WARNING:** *Be sure that you do not store extraneous files in your project source file area on your PC or else the source file download will grow and the procedure may take longer than needed*

The state of the application program following download is determined by selection for **Operation following Project Download** in the [CONFIGURATION/GENERAL SETTINGS](#) web page. The application remains in this state until user changes the program state or the module is reset.

7. The module includes a predefined **Cycle Instruction Overrun** watchdog to prevent the user program from excessively looping without completing a normal cycle. This watchdog uses a software timer to measure each module cycle and limits maximum cycle time to one (1) second.
8. The module firmware also includes a **System Watchdog** with preset of 6 seconds that expires only if the module operating system becomes inoperable. The expiration of the System Watchdog will cause the JACP module to reboot.
9. If a module execution error is detected, the event is recorded in the Event Log and module will enter the **ERROR** state. **ERROR** state can be cleared by connecting Workbench to the module or by resetting the module via web page or **RESET** button (if either is enabled).

5.2 Module Startup

This section describes the sequence of events that occur during a power-on startup or after a module reset.

NOTE

All CTI boot files are encrypted to provide protection against malicious code by ensuring that only CTI authorized firmware is loaded

- 1) The yellow ERROR LED is set ON by hardware when power is applied to the module. This provides indication that the module is powered and attempting to decrypt and load the contents of the boot.bin file on the System SD card. If the SD card is missing, or the SD card does not contain a boot.bin file, or the encryption setting or key is invalid, startup is halted and the error LED will remain on. Also note that the SYSTEM SD card must be formatted as FAT32 (only the USER SD card supports EXFAT)
- 2) If step 1 is successful, the module starts a ‘Secure boot’ process. Each component of the image file (boot manager, operating system, module execution engine, FPGA system, firmware drivers, etc.) is checked for authenticity using the encryption key. If verified, the boot is initiated. Otherwise, startup is halted and the ERROR LED remains on.
- 3) At the beginning of the boot process, the ERROR LED is turned OFF and a scrolling decimal point appears on the Alphanumeric Display, indicating the operating system and execution engine are booting. *If the animation continues for more than 30 seconds, this indicates a boot error.*
- 4) When the operating system is running, the firmware version number is displayed on the front panel Alphanumeric Display in “X.YY” format where “X” is major revision and “YY” is minor revision. This number remains displayed for two (2) seconds, and then is replaced by the IP Address/Subnet and/or Error Codes as specified in the [CONFIGURATION/GENERAL SETTINGS](#) web page.

By default, if an IP address has not been set by other means, a link local IP address, which is automatically created at startup, will be displayed with a prefix of “AIP”. This IP address, which is not routable, can be used as a temporary IP address until other IP assignment methods are configured. You

can cause the Auto-IP address to always be displayed by selecting the “Always Display Auto-IP” option in the CONFIGURATION/GENERAL SETTINGS web page.

If an error code is displayed, you can determine the cause by referencing [APPENDIX A: SYSTEM ERROR CODES](#) in this manual or accessing the ERROR DESCRIPTIONS & STATUS web page.

- 5) Application state is then set to the state specified in the General/Configuration web page Startup Options.

5.3 Reset Pushbutton Operation

When enabled, the **RESET** pushbutton provides a direct method to clear exceptions, reset module configuration values to default values, or restore factory defaults without requiring access to *Janus Workbench* or the module web server. In cases where the user selected password(s) for web server access is lost, this is the only method that can be used to clear existing passwords. No universal or developer-embedded “back door” password is allowed in the system. All pushbutton operations are logged in the module event log. The **RESET** pushbutton will function only when Switch 3 is in the CLOSED (ON) position.

The following actions may be initiated by depressing the **RESET** button:

- **CLEAR EXCEPTION**

Pressing and holding the recessed pushbutton for greater than 5 seconds causes the Janus module to reset and return to normal operation following a System Exception.

When the button is pressed for one second, the front panel display shows countdown for ‘seconds to module reset’ (4-1). If the pushbutton is released any time during this period, the operation is aborted. If the button remains pressed until the countdown reaches zero, the display changes to **rE** (indicating pending reset). Releasing the button at this time initiates the module reset.

If the module is in **RUN** or **LOGIC STOP** state when the **CLEAR EXCEPTION** event is detected, the application must be halted before the reset is triggered.

The module startup operation following the reset is specified by **Operation following Module Reset** setting in CONFIGURATION/GENERAL SETTINGS page of the web server. See [Section 4.1 General Settings](#).

- **RESET CONFIGURATION SETTINGS**

Pressing and holding recessed pushbutton for greater than 10 seconds causes the module to reset, returning all configuration settings to their default settings.

The following settings are reset by this action:

- Startup Mode
- Alphanumeric Display Options
- Method for Setting IP Address
- IP Address / Subnet Mask (all configured)
- Web Server Password Protection Enable and associated Username/Password List
- Module Clock Time Set / Sync Method and associated settings

After the button is pressed and held for 5 seconds, the display will show **rE** (see **CLEAR EXCEPTION** description above). If the button press is maintained for another second, the front panel display shows

countdown for 'seconds to **CONFIGURATION RESET**' (4-1). If the pushbutton is released any time during this period until countdown reaches zero, the button press is treated as a **CLEAR EXCEPTION** event as described above.

If the button press is held until the **CONFIGURATION RESET** countdown completes, the display changes to **Cr** (indicating pending **CONFIGURATION RESET**). Releasing the button at this time initiates the **CONFIGURATION RESET** event.

If the module is in **RUN** or **LOGIC STOP** state when the **CONFIGURATION RESET** event is detected, the application will be halted and operational data stored (equivalent to ending the application from Workbench) before the reset is triggered.

When the application is stopped, all module configuration settings (as reported on the module Configuration web pages) are restored to default values.

The module is then reset, and the module remains stopped on the subsequent startup.

- **RESTORE FACTORY DEFAULTS**

Pressing and holding the recessed pushbutton for greater than 15 seconds causes the module to return to as-shipped factory defaults by pressing the button for greater than 15 seconds. This action will reset all PLC configuration settings to default (see list in **RESET CONFIGURATION SETTINGS** section above) and delete all user files including application programs and source files from the System SD card.

After the button is pressed and held for 10 seconds, the display shows **Cr** (see **RESET CONFIGURATION SETTINGS** description above). If the button press is maintained for another second, the front panel display shows countdown for 'seconds to Factory Reset' (4-1). If the pushbutton is released any time during this period until countdown reaches zero, the button press is treated as a **RESET CONFIGURATION** event as described above.

If the button press is held until the **FACTORY RESET** countdown completes, the display changes to **Fr** (indicating pending **FACTORY RESET**) and displays this value until the button is released or power is removed. Releasing the button when **Fr** is displayed initiates a **FACTORY RESET** event.

If the module is in **RUN** or **LOGIC STOP** state when the **FACTORY RESET** event is detected, the application will be halted and operational data stored (equivalent to stopping the application from Workbench) before the reset is triggered.

5.4 HTTP Data Server

The JACP module includes an HTML Data Server that provides an embedded HMI function. Using the Data Server, you can access "live" controller variable data using any recent version of a standard web browser (Microsoft Edge, Internet Explorer 11, Mozilla Firefox, or Google Chrome) on any PC or internet-capable smart device. Variable data is constantly updated from the controller database. Read/write services allow you to modify variables values from the web page based on a user-designed graphics page configuration. You have complete control over which module control variables are accessible via the web browser. See the *Janus Workbench* help system for information regarding configuration and use of the Data Server.

Access to the Data Server can be controlled via Username/Password set in the module web server **CONFIGURATION/NETWORK SETTINGS** page. If you wish to encrypt the communications between the web server and the JACP module, secure (https:) connections can optionally be selected (see [Section 4.3 Security Settings](#)).

CHAPTER 6 UPDATING FIRMWARE

6.1 Overview

The JACP module stores the operating firmware on the System SD Card. You can replace the current operating firmware with a different version to correct problems or add new features.

Prior to updating firmware, you will need to obtain a firmware update file for the JACP module. This file can be downloaded from the CTI website <http://www.controltechnology.com/downloads/>. After obtaining this file, you should save it to a file on your PC or on an accessible network drive.

The firmware update process is a three-step operation consisting of the following steps:

- 1) Verification of an encrypted firmware file to ensure the file contains only “trusted executables” before it is installed on the JACP module
- 2) Extraction of OS/firmware file,
- 3) Copy of the OS/firmware file to the root folder of the System SD card where it will execute after the next module reset.

There are three methods for updating firmware. They are described in the following sections.

6.2 User SD Card Firmware Update

The procedure requires the following steps:

- 1) Copy the new firmware file downloaded from CTI website to root directory of an SD card. The firmware file can be a compressed zip file or binary file (boot.bin) extracted from the zip file. NOTE: *ensure that only one .zip or boot.bin file exists on the root directory*
- 2) Turn off power to the chassis, remove the JACP module, set Module Switch 2 to CLOSED position, ensure Module Switch 4 is OPEN, and install the SD card into the User SD Card receptacle (See location [here](#)) Then re-install the module into the chassis, and restore power to the chassis.
- 3) On power-up, module attempts to find the firmware file in the root directory of the front panel SD card.
- 4) If any of the following errors occur, **UFEr** indicating **Firmware Update Error** is displayed and the appropriate error code (see below) is generated.
 - If a properly formatted SD card is not inserted into the user SD card receptacle, Error 370 (**User SD Card Not Accessible**) is reported.
 - If file with '.zip' extension or file named 'boot.bin' cannot be found in the SD card root folder, Error 250 (**User SD Card – Update File Not found**) is reported.
 - If the update file is found but not valid for the JACP product, Error 260 (**User SD Card -Invalid Update File**) is reported.

If one of these errors exists, the firmware update procedure is terminated and you must correct the problem and repeat the firmware procedure.

- 5) If the firmware file is found and validated, **UFdn** is displayed on the front panel display to indicate success. This action is also so reported in the Event Log.
- 6) When the firmware has been successfully updated, turn off power to the chassis, remove the module, and set Module Switch 2 to the OPEN position. You may also choose to remove the SD card from the user SD card receptacle at this time. Then re-install the module and re-apply power to the chassis to return to normal operation.

6.3 Remote Firmware Update

The **Remote Firmware Update** method allows the PLC firmware to be updated via network connection to web server. This can be accomplished only when the JACP module is running. Remote firmware update consists of the following steps:

- 1) Ensure that Switch 1 is set to the CLOSED Position to enable *Remote Firmware Update*.
- 2) Use a web browser to access PLC web server and select **Firmware Update** web page. Username/Password authentication is required to access this page if enabled.
- 3) When firmware update is initiated, the module operational mode is checked. To update firmware, the module must be in **APPLICATION STOP** mode.
 - If the application is in **RUN**, **LOGIC STOP**, or **ERROR**, a status message will be displayed informing you that authorization to halt PLC application is required. You can authorize this action by checking the acknowledgement checkbox. After doing so, a status message will inform you that you can proceed with the firmware update.
 - If the application is stopped (**Application Stop**), you can proceed with the firmware update. A status message will be displayed informing you that the module is ready for firmware update.

NOTE

The [Refresh] button can be pressed at any time to recheck PLC operational mode and update the module status. If [Refresh] is pressed after the warning message is acknowledged, the acknowledgement checkbox and status message is cleared and updated based on the current Module operational state.

- 4) Select the firmware file to download to the module by pressing the [**BROWSE**] button. The selected file can be a zip file – normally named CTI_JANUS_ACP_Vnn_nn.zip (where nn_nn represents the version number) or an uncompressed binary file (boot.bin).
- 5) After the firmware file is selected, press the [**UPDATE FIRMWARE**] button to initiate the firmware update or cancel the operation by leaving the webpage (either close browser window or view a different webpage).

NOTE

If [UPDATE FIRMWARE] is selected, the Remote Firmware Update operation must run to completion (Success or Error). The module must remain powered and operational throughout this process. See [Section 6.4 Direct File Replacement](#) for recovery options if power is lost during the firmware update operation.

- 6) If file download fails for any reason, Error Code 250 (**Update File Not Found**) is generated and error message is displayed in the Status window of the web page.
- 7) If the file download succeeds, the firmware file is copied to a temporary folder on the SD card and validated to ensure it is for proper product/model. If the file validation fails, the firmware update is terminated. Error Code 260 ('Invalid Update File') is generated, and error message is displayed in the Status window on web page.

- 8) If the validation succeeds, the web page status message is updated to indicate the **Firmware Update is complete and module is rebooting**. This action is also reported in the Event Log.
- 9) The module then resets to complete the operation and restarts using the updated firmware.

During the module reset, the browser connection to the web server is lost. A new connection to the web server is required to verify the updated firmware is operational. This can be accomplished by pressing the [REFRESH] button on the web page or the 'Reload current page' button on the browser.

NOTE

*If the web page is reloaded via the [REFRESH] button or browser 'Reload' button while the module is still rebooting, the browser may reroute the user to a 'Connection timed out' page. In that case you must use the 'Reload' button on the browser to reload the **Firmware Update** web page.*

6.4 Direct File Replacement

The Direct Firmware File Replacement method is provided as a means to recover from a failed firmware update, or missing / corrupted SD card. Since the module is not operational, neither of the traditional methods for updating firmware can be used.

- 1) Unzip the compressed firmware file downloaded from CTI website (CTI_JANUS_ACP_Vnn_nn.zip) to extract the boot.bin binary file.
- 2) Copy the *boot.bin* file to the root directory of a SD card. No other files are required.
- 3) Turn off power to the base, remove the module, and insert the SD card containing the boot.bin file into the System SD card slot (see [Section 3.2.2](#)).
- 4) Ensure Module Switch 2 and Switch 4 are in the OPEN position.
- 5) Reinstall the module and restore power to the base.
- 6) The module should start up as described in [Section 5.2](#).

CHAPTER 7 EMBEDDED WEB SERVER

The product embedded web server displays information about the operation of the JACP module and provides a means to configure product operation. The web pages are described in the following sections.

7.1 Product Information

This page provides information about the module

- **Product Number**
- **Product Name**
- **Serial Number**
- **Manufacture Date**
- **Module Identifier:** Assigned by user in the GENERAL SETTINGS page
- **Hardware Configuration:** Designator that allows software to determine hardware compatibility
- **Module Firmware Version**
- **Module Firmware Date**
- **FPGA Version**
- **Build Information 1 & 2:** (CTI development and support information)
- **Clock Synchronization Mode:** Determines how the module clock is set)
- **Startup Mode:** Determines how the module starts up when reset or powered up
- **User SD Card Status:** If inserted, displays Utilization Percentage
- **DNS (Domain Name Service) Address Method** (Auto/Manual)
- **Primary DNS Server IP Address**
- **Secondary DNS Server IP Address**
- **Domain suffix**
- **HTTPS Basic Authentication Enabled:** Authentication for webserver access
- **HTTPS Encryption Enabled:** Encryption of web server traffic
- **Ethernet MAC Address**
- **Internal Switch Mode**
- **CPU Temperature (° C)**
- **Dipswitch Settings**
- **User Jumper Selections**
- **Network Settings: For Primary and Alternate subnets and AutoIP Address display**

7.2 Application Information

This page contains information about the current application.

- **Project Name/Compile Version**
- **Project Compile Timestamp**
- **CTI Workbench Compiler Version**
- **Session Number:** Session ID of the current session
- **Current Operational Mode:** (APPLICATION STOP / LOGIC STOP/ RUN / ERROR)
- **Active Error Codes:** See [Error Descriptions and Status](#) web page description for details.
- **System Resources:** Displays memory, file and socket utilization for the operating system.
- **Product Resources:** Displays memory, file, and socket utilization for the product.
- **Components Configured:** Indicates configuration status of fieldbus drivers and other facilities.
- **Component Errors:** Indicates components that are in an error state.
- **Non-configurable System Element Errors:** Indicates elements that are in an error state.
- **Locked Variables:** Lists variables that are locked (forced).

7.3 Configuration

7.3.1 General Settings

This page contains settings that apply to the general operation of the module.

- **Module Identifier** - Optional 16-character text field used to identify the controller
- **Operation following Module Reset**
 - Restore Last State (Default)
 - Application Stop
 - Auto-Run Cold Start,
 - Auto-Run Warm Start
- **Operation following Project Download from Janus Workbench**
 - Application Stop - Logic programs and fieldbuses are stopped
 - Logic Stop – Logic programs stopped/ Fieldbuses execute (Default)
 - Run – Logic programs and fieldbuses execute
- **Front Panel Display Items**
 - Display Primary Network IP on Front Panel: Displays the Primary IP Address when enabled.
 - Display Subnet IP address on Front Panel: Displays IP address of configured alternate subnet when enabled.
 - Always Display Auto-IP on Front Panel: Always displays the automatically created IP address when enabled. *When not enabled, the Auto-IP address is displayed only when the module IP address is not set by other methods.*

The new parameters go into effect immediately after clicking the APPLY button and confirming the action.

NOTE: If both display options are disabled, the front panel alphanumeric display will be blank when no error conditions are active.

7.3.2 Network Settings

This page sets the IP parameters for the module and configures how the embedded switch forwards Ethernet frames.

- **Primary Subnet Configuration** (configuration is required)
 - Automatic (DHCP): Designates that IP parameters will be assigned using DHCP (Dynamic Host Configuration Protocol)
 - Static: IP parameters will be entered in the boxes below
- **Alternate Subnet Configuration** enables the module to communicate on an additional IP subnet. The alternate subnet must be unique. Subnet configurations that overlap other configured subnets will be rejected. See [Appendix C](#) for more information.
- **Internal Ethernet Switch Configuration.** Allows you to configure how Ethernet frames will be forwarded between the front panel Ethernet ports. See [Appendix C](#) for additional information.

New configurations go into effect immediately after clicking on the APPLY button and confirming the action.

7.3.3 Security Settings

This page sets the security requirements for access to the following web pages: Configuration, File Management, Firmware Update, and Custom HTML (graphics) web pages.

- **HTTP Basic Authentication** (Web Server Password Protection)
 - No Authentication Required (Disables Password Protection)
 - Allow only the following users (Enables Password Verification)
If selected, allows user to create 'Password List' containing up to 16 entries. Each entry consists of a unique Username (1-16 characters) and password (1-16 characters). The following characters may be used in password: a-z A-Z 0-9 ~ @ % ^ _ + = { } [] : , . ? / .
- **HTTPS Encryption:** Encrypts the communications with the web server when the box is checked.
Checkbox to 'Use HTTPS Encryption' when selected (Default = Disabled)

When [APPLY] button is pressed, the updated configuration parameters are saved to the database and a confirmation message is displayed.

7.3.4 Clock Settings

Determines how the module clock is set

- **Set Current Time** – Enables manual entry of the date and time.

- Date (in YYYY-MM-DD format)
- Local Time (formatted as HH:MM AM/PM)

- **Remote NTP Server** – Obtains date and time from an NTP (Network Time Protocol) server.

The NTP Server poll rate is determined by the clock discipline algorithm designed to maximize accuracy while minimizing network overhead. The actual poll interval depends on clock accuracy and offset differences, called “clock jitter”. The algorithm also includes provisions to further reduce network load when the NTP Server is unreachable.

The NTP specifications allow one large time adjustment when first connected to the server, but avoids additional large corrections. This means it may take a few hours to correct a clock that was set incorrectly after the system was started.

The JACP module monitors the connection to the Remote NTP Server and generates Error 595 (Remote NTP Server Error) and logs an event when the connection is lost. The status of the connection is checked at startup (or when ‘Sync Time Method’ on the *Clock Settings* webpage is changed to ‘Use Remote NTP Server’) and periodically every hour. The error condition is cleared and event logged when communications is received from the NTP Server.

The following must be entered when ‘Remote NTP Server’ selected:

- Time Zone Region
- Time Zone City
- Sync Host IP Address

- **CTI Data Cache Host PLC**

The CTI Data Cache interface reads time from the Host PLC immediately after the connection/validation process and in following cases:

- The Host PLC indicates the PLC Clock time/date has been changed,
- Approximately every 2 hours.

When the [APPLY] button is pressed, entries will be validated and error message displayed if necessary. If no errors are detected, a confirmation message will be displayed. The new parameters go into effect immediately after the message is acknowledged.

- **Block Transfer Host PLC**

The Block Transfer interface reads time from the Host PLC immediately upon configuring the SFIO interface and then once every 4 seconds.

7.3.5 File Management

This page allows you to perform operations on the module files. The following operations can be performed.

- **Copy to User SD Card:** Copies selected user file(s) from the System SD card '/ctiplc' folder
- **Copy from User SD Card:** Copies selected user file(s) or folder to the System SD card '/ctiplc/user' or '/ctiplc/graphics' folder
- **Replicate the System:** Copies files from System SD card to User SD card necessary to replicate the OS and application on another JACP module
- **Download File to Computer:** Downloads a selected file from the System SD card to the PC 'Downloads' folder
- **Upload File from Computer:** Uploads a single file from the PC to the '/ctiplc/user' or '/ctiplc/graphics' folder on the System SD card
- **Import Public Certificates from Computer:** Saves the selected X.509 certificate file (*.der) to the System SD card.
- **Import Private Key from Computer:** Saves the selected Private Key file to the System SD card.
- **Delete User Area Files:** Deletes selected files from the '/ctiplc/user' or '/ctiplc/graphics' folder on the System SD card.
- **Copy Core Dump Files to User SD Card:** Creates a zip file of the selected Core Dump file and transfers it to the User SD card.
- **Copy Core Dump Files to Computer:** Creates a zip file of the selected Core Dump file and transfers it to the computer.
- **Delete Core Dump Files:** Deletes selected Core Dump files on the System SD card.

NOTES:

- An error message will be displayed if the selected files cannot be copied.
- The [REFRESH] button can be used to check SD card status.
- The [COPY] button initiates the selected file transfer. For operations that access the User SD card, it must be inserted and detected by the system (via Status message) before SD card file transfer can start.
- The [IMPORT] button initiates the import operation.
- The **File Management** operation can be cancelled by the user at any time before the [COPY] or [DELETE] pushbutton is pressed by selecting a different web page or closing the browser window. Once the button is pressed, the file transfer will continue until successful completion or an error condition occurs.

7.3.6 Firmware Update

This page provides a method to initiate a *Remote Firmware Update* for the JACP module. For more details, see [Section 6.3](#).

- [REFRESH] pushbutton is used to recheck the module operational status.
- [CHOOSE FILE] pushbutton displays a File Explorer window when pressed. This allows navigation through PC/Network drives to select the Firmware Update file to download.
- [UPDATE FIRMWARE] button initiates the firmware update process when pressed. All interlocks (User Switch 1 position, Warning Acknowledgement checkbox, and PLC operational state) must be met before firmware update process will start.

NOTE: The **Remote Firmware Update** procedure can be cancelled any time prior to pressing the [UPDATE FIRMWARE] pushbutton by selecting a different web page or closing the browser window. Once the button is pressed, firmware update will continue until successful completion or error.

- [STATUS] window that provides information on the current state of the firmware update process.

7.3.7 Product Reset

This page provides a method to remotely the reset of the JACP module. Remote reset is allowed only when module Switch 5 is in the CLOSED position. The following resets are allowed:

- Clear Exception
- Reset Configuration Settings
- Restore Factory Defaults

See [Section 5.3](#) for description of reset options.

NOTE:

The connection to the PLC web server will be lost after any of the above actions are taken. Any action other than 'Clear Exception' will force the PLC to lose its IP address.

7.4 Event Log

The Event Log maintains a history of user actions, operational states, application settings, and system-level errors that affect the module operation. The Event Log is an extremely useful tool for “post event” analysis for determining the events leading up to an unexpected operation or error condition.

The Event Log record format includes the following data:

- 1) Event Text / Event ID
- 2) Project Name / Version Number
- 3) Event Category Text / Category ID
- 4) Record Creation Date / Session Number
- 5) Update Time / Number Repetitions
- 6) File / Line Number that Logged the Event (not shown)

The location of these fields in the Event Log record is shown below:

Event Log	
0 Pending Events, Max Pending Events = 1	
9	Category: Product Information Events (54) Ethernet Link Status Change (15003) Ethernet Ports Active: A
8	Category: Application Events (6) Workbench Application Start (50017) Project: PRTEST2 [V3] Warm Start
7	Category: Application Events (6) Firmware Startup (50000) Janus ACP Classic V1 v01.04 2022-06-20
	Created[2022-08-22 17:14:40] Session#6 Updated[2022-08-22 17:14:40] Reps:0 CDisplay.cpp InternalThreadEntry 347 0
	Created[2022-08-22 17:14:39] Session#6 Updated[2022-08-22 17:14:39] Reps:0 AbramsFalls.cpp _StartVmThread 1340 0
	Created[2022-08-22 17:14:38] Session#6 Updated[2022-08-22 17:14:38] Reps:0 AbramsFalls.cpp main 447 0

The Event Log records are also color-coded to aid in spotting startup and fatal error events. Startup messages (logged immediately after boot) are GREEN (see above), and fatal error events are colored RED.

The Event Log also incorporates a filtering algorithm to detect duplicate messages. This prevents a single or a series of repetitive actions (such as a toggling error state condition) from filling the Event Log. Any event that is repeated within a one-hour period causes an update to the ‘Timestamp’ and ‘Repetition Count’ (item 5 above) in the original record instead of creating a new record each time an event is detected.

7.5 Statistics

This section will display statistics related to the Communication Sessions, PLC cycles, and Fieldbus Protocols (excluding EIP Tag Client, EIP Tag Server, EIP Scanner, and EIP Adapter, and services controlled by the TCP/UDP Management functions in user logic programs). All counts are reported since application was last started (transfer from APPLICATION STOP). These counts are automatically reset only on next transfer from APPLICATION STOP.

The following statistics categories are available:

- **Communications Sessions:**
 - Active Communications Sessions displays information for data transfers to/from each connected device.
 - Closed Communications Sessions: Displays information for TCP connections that have closed since last power cycle. The list is limited to the last 200 closed connections. The information for the oldest closed connection(s) in excess of 500 will be overwritten.
- **Cycle Statistics:** Displays information regarding the following:
 - Module scan
 - Binding Subscriber
 - I/O Exchange
 - Modbus Master and Slave
 - Binding Publisher
 - User Logic Programs
 - Ethernet/IP
 - I/O Exchange Details
- **Fieldbus Statistics:** Displays information regarding configured fieldbus drivers (except Modbus).
- **Net Statistics:** Displays information regarding the TCP/IP stack.
- **Past Sessions:** Displays statistics from previous sessions. A session is started when the controller boots up and ends immediately before the next time the module boots up.
- **Serial Port Statistics:** Displays statistics related to serial port communications

7.6 Error Descriptions and Status

This page lists all module error codes and provides the following information for each:

- Error Number
- Error Description
- Error Count
- Start Timestamp
- End Timestamp

Active Errors are shown in red.

7.7 Display All Pages

This selection groups all web server pages into a page and provides an easy method for the user to “save all web data and statistics” when required for troubleshooting and analysis.

7.8 Custom HTML (graphics)

Displays list of user-generated graphics pages that have been created and downloaded to the appropriate folder (ctiplc/graphics) on the System SD card. You can display a graphics page directly by selecting the corresponding file from this list. The appropriate security options as set in the *Security Settings* configuration are applied to all graphics web pages.

7.9 Acknowledgements

Displays third-party software used in the CTI products in accordance with their open-source license policies.

7.10 Product Support

Opens browser connection to the Control Technology Inc. home page.

APPENDIX A: SYSTEM ERROR CODES

NOTE

*When more than one error exists, the highest priority error code will be displayed on the alphanumeric display. When this error is cleared, if another error exists, the next highest priority error code will be displayed. When multiple errors exist with the same (highest) priority, the codes are alternately displayed.
The **Error Descriptions and Status** web page will display all current errors.*

CPU Startup Errors

Error Code	Description	Operation	Error Recovery
010	No Network Configuration	Module stopped.	Configure CPU via Web Server or use SD Card Ethernet Port Setup to specify Module IP Address.
020	Ethernet Port Switch Configuration error (not set for 'Full Duplex' or '10/100mb' operation)	Module stopped.	Cycle power to Module. Contact CTI.
030	Manufacturing Data Checksum Error	Module stopped.	Cycle power to Module. Contact CTI.
050	Duplicate IP Address detected on network NOTE: This condition is checked every minute while module is active.	Module state is unchanged.	Check Event Log for details. Resolve IP address on conflicting devices. Error is cleared after 2 consecutive probes report no duplicate IP Address (3 minutes max). Note: duplicate IP addresses can cause random control problems.
070	Configuration Settings Missing or Invalid	Module stopped.	Configure CPU via Web Server. Download program from Janus Workbench.

Module Run Mode Startup Errors

Error Code	Description	Operation	Error Recovery
080	No Application Program Found	Module stopped.	Download program from Janus Workbench.
085	Specified Startup Mode Unavailable (Application cannot start as configured due to abnormal shutdown, unsupported program version, or PLC installed in I/O module slot with application that includes Local I/O)	Module stopped.	Two possible reasons: (1) PLC could not complete an orderly shutdown due to loss of power. Connect Workbench to start application or press <i>Clear Exception</i> button to trigger "Cold Start". (2) PLC inserted into I/O module slot 1-16 and application includes a Local I/O config. Modify application to remove LIO config or move PLC to Slot 0.
090	Incompatible Application Program	Module Stopped	Recompile Program with correct module model/firmware version or update firmware.
150	CTI Data Cache Client driver failed to start	Module stopped.	Reset Module. Contact CTI.
160	CAMP Client driver failed to start	Module stopped.	Reset Module. Contact CTI.
165	CAMP Server driver failed to start	Module stopped.	Reset Module Contact CTI.
170	MODBUS Client driver failed to start	Module stopped.	Reset Module. Contact CTI.
175	MODBUS Server driver failed to start	Module stopped.	Reset Module. Contact CTI.
180	Ethernet/IP Scanner driver failed to start	Module stopped.	Reset Module. Contact CTI.
185	Ethernet/IP Adapter driver failed to start	Module stopped.	Reset Module Contact CTI.
187	Ethernet/IP FlexIO driver failed to start	Module Stopped	Reset Module Contact CTI.
190	Ethernet/IP Tag Client driver failed to start	Module stopped.	Reset Controller Contact CTI.
195	Ethernet/IP Tag Server failed to start	Module stopped.	Reset Module. Contact CTI.
210	MQTT Client driver failed to start	Module stopped.	Reset Module. Contact CTI.
215	OPCUA Server failed to start	Module Stopped	Reset Module. Contact CTI
220	HTML5 Data Server driver failed to start	Module stopped.	Reset Module. Contact CTI.
225	Block Transfer Start Error	Module stopped.	Reset Module. Contact CTI.

Firmware/Configuration Update Errors

Error Code	Description	Operation	Error Recovery
250	File Not Found	Occurs when file download fails during 'Remote Firmware Update' or expected file is not found on user SD card during 'User SD Card Firmware Update' or 'SD Card Ethernet Port Setup'.	Ensure that module switches 2 and 4 are not CLOSED. Retry download, or copy appropriate file to root directory of User SD card and re-insert card into User SD Card receptacle.
260	User SD Card – Invalid File	Occurs when no valid firmware update file is found during 'User SD Card Firmware Update' or 'SD Card Ethernet Port Setup' operations)	Ensure appropriate file is in SD card root directory. Check contents of 'cti.ini' file if error detected by 'SD Card Ethernet Port Setup' utility. Verify firmware file name (*.zip) matches product being updated for 'Firmware Update'. Try using a different SD card if performing 'User SD Card Firmware Update'. If condition persists, contact CTI.

Execution Errors

Error Code	Description	Operation	Error Recovery
310	System Exception Error (Detected after CPU reset following Segmentation Fault or Firmware Error)	System restarts. Module remains stopped after restart.	Connect Workbench and transfer to RUN or use CLEAR EXCEPTION button to restart CPU. Contact CTI Support.
320	System Watchdog Timeout (Detected after CPU reset following Segmentation Fault or Firmware Error)	System restarts. Module remains stopped after restart.	Connect Workbench and transfer to RUN or use Reset button to restart CPU. Contact CTI Support.
330	Program Logic Error	Module enters ERROR state (Logic programs and fieldbus protocols are stopped).	This condition most likely caused by 'Infinite Logic Loop' or 'Bad Array Index'. Connect Workbench to correct problem and transfer to RUN or use 'Clear Exception' button to restart CPU.

SD Card Errors

Error Code	Description	Operation	Error Recovery
350	System SD Card Disk Full (no further writes to System SD card)	Module continues to run, but database updates, user file functions, and program downloads are prohibited.	Use Web Server 'SD Card File Management' page to transfer or delete user files.
355	System SD Card Free Space Limit (disk > 90% full)	Module continues to run, but all user file access functions are disabled (should return errors when called).	Use Web Server 'SD Card File Management' page to transfer or delete user files
360	System SD Card Free Space Warning (disk > 80% full)	Module continues to run normally.	Use Web Server 'SD Card File Management' page to transfer or delete user files
370	User SD Card Not Accessible (Missing, Incompatible, Unformatted or Write-Protected)	Module continues to run normally	Cancel function that is using User SD Card, or correct problem with SD card.

Client Communication Errors

Error Code	Description	Operation	Error Recovery
470	CTI Data Cache Client: Host TCP Connection Failure	Module continues to run normally	Correct connection and/or Host settings
475	CTI Data Cache Client has non-CTI MAC Address	Module continues to run normally	Remove DC Client from application or force creation of new 'cti.ini' file to update MAC Address
480	CTI Data Cache Client Incompatible Host PLC Firmware	Module continues to run normally	Update Host PLC firmware
485	CTI Data Cache Client: Host PLC Registration Failed (PLC already has max number of connections)	Module continues to run normally	If replacing an existing Data Cache module, remove old module before connecting new one.
490	CTI Data Cache Client: Host PLC Link Inactive	Module continues to run normally	Correct connection to Host PLC. Ensure Host PLC is online.
510	CTI Data Cache Client: Host PLC Fatal Error	Module continues to run normally	Clear Host PLC Fatal Error
515	CTI Data Cache Client: Host PLC in Program Mode	Module continues to run normally	Change Host PLC mode to RUN
520	CTI Data Cache Client: Inaccessible PLC Address	Module continues to run normally	Check that CTI Data Cache configuration matches PLC memory configuration

Error Code	Description	Operation	Error Recovery
525	CTI Data Cache Client: No Memory Buffers Available for Data Write to Host PLC (too many Write requests during one Host PLC scan).	Module continues to run normally. Error clears next scan cycle.	Increase Host PLC time slice for CTI Data Cache interface. Set "fixed" IEC PLC cycle time.
530	Block Transfer: Host PLC does not support SFIO	Module continues to run normally	Choose a different PLC or data transfer protocol. Note: Janus controller does not currently support SFIO.
531	Block Transfer: Unable to Issue Request to SFIO	Module continues to run normally	Ensure that the Block Transfer configuration matches the PLC memory configuration
532	Block Transfer: Timeout Error	Module continues to run normally	
534	Block Transfer: Host PLC Fatal Error	Module continues to run normally	Clear Host PLC Fatal Error
536	Block Transfer: Host PLC in Program Mode	Module continues to run normally	Change Host PLC mode to RUN
538	Block Transfer: Inaccessible Host PLC Memory Address	Module continues to run normally	Ensure that the Block Transfer configuration matches the PLC memory configuration
539	Block Transfer: SFIO Message queue full	Module continues to run normally. Error clears on next controller cycle	Since the error clears once the queue has space, there is no need for user intervention to recover from the error.
540	CAMP Client Error (Connection to servers or communication failed)	Module continues to run normally	Check configuration and connection to CAMP Server(s).
550	MODBUS Client Error (Connection to servers or communication failed)	Module continues to run normally	Check configuration and connection to Modbus Server(s).
560	Data Exchange Error (Subscriber not receiving data from one or more Publishers).	Module continues to run normally	Check Global Binding configuration and connection to Data Exchange Publisher device.
570	Ethernet/IP Scanner Error (Connection to servers or communication failed)	Module continues to run normally	Check configuration and connection to EIP Adapter(s).
575	Ethernet/IP FlexIO Error (Connection to Adapters or I/O communications failed)	Module continues to run normally	
580	Ethernet/IP Tag Client Error (Error is default at startup when configured)	Module continues to run normally	Check configuration and connection to EIP Server.

Error Code	Description	Operation	Error Recovery
590	MQTT Client Error (Connection to broker or communication failed)	Module continues to run normally	Check configuration and connection to MQTT broker.

* Not displayed on Alphanumeric Display

Hardware Errors

Error Code	Description	Operation	Error Recovery
620	Real-Time Clock Access Error (firmware unable to read or write RTC)	Module continues to run normally	This indicates a hardware error. Error clears if future attempt to access the RTC is successful. Contact CTI Support.
630	Processor High Temperature Warning	Module continues to run normally	This indicates a serious issue with CPU internal temperature. User should lower ambient temperature and/or shutdown CPU if temperature does not return to normal.

APPENDIX B: IP ADDRESS INFORMATION

IP Address Nomenclature

IP Address

Every host interface on a TCP/IP network is identified by a unique IP Address. This address is used to uniquely identify the host device, such as a workstation or communications module, and the network to which the host belongs.

Each IPV4 Address consists of 32 bits, divided into four 8 bit entities called *octets*. An IP Address is expressed in *dotted notation*, with each octet expressed as its decimal equivalent. See the example below.

Notation	Octet 1	Octet 2	Octet 3	Octet 4
Binary	11000000	11011111	10110001	00000001
Decimal	192	223	177	1

Although an IP Address is a single value, it contains two types of information: the *Network ID* and the *Host ID*. The Network ID identifies the IP network to which the host belongs. The Host ID identifies a specific IP host on that IP network. All IP hosts on a particular local area network must have the same network ID. Each IP host on a particular local area network must use a unique Host ID.

Address Classes

The Internet community originally defined network classes to accommodate networks of varying sizes. The network class can be discerned from the first octet of its IP Address.

The following table summarizes the relationship between the first octet of a given address and its Network ID and Host ID fields. It also identifies the total number of Network IDs and Host IDs for each address class that participates in the Internet addressing scheme.

Class	First Octet Value*	Network ID	Host ID	Number of networks	Number of hosts per net
A	1-126	First Octet	Last 3 Octets	126	16,777,214
B	128-191	First 2 Octets	Last 2 Octets	16,384	65,534
C	192-223	First 3 Octets	Last Octet	2,097,151	254

* Address 127 is reserved for loopback testing and inter-process communication on the local computer; it is not a valid network address. Addresses 224 – 239 are used for Class D (IP multicast).

Subnet Mask

Used alone, the designation of network classes proved to be inflexible. Assigning large numbers of devices to the same network is impractical considering performance, topology, and security constraints. The Subnet Mask, sometimes called the Network Mask, provides a flexible means of designating the Network ID portion and Host ID portions of the network address. In modern TCP/IP implementations, the network class is largely ignored, except for setting the default subnet mask

The subnet mask is a collection of 32 bits that distinguish the network ID portion of the IP address from the host ID. Subnet masks are implemented by assigning 1's to bits that belong to the network ID and 0's to the bits that belong to the host ID. To represent the mask, the 32-bit value is converted to dotted decimal notation or CIDR (Classless Inter-Domain Routing) notation, a commonly used alternate. The CIDR notation counts the number of bits in Network ID portion of the address (bits that are set to 1). The count is preceded by a slash. See the example below.

Bits for Network Mask				Dotted Decimal Format	CIDR Format
11111111	00000000	00000000	00000000	255.0.0.0	/8
11111111	11111111	11110000	00000000	255.255.240.0	/20
11111111	11111111	11111111	00000000	255.255.255.0	/24

For example: when the IP address is 128.54.177.97 and the network mask is 255.255.255.0, the Network ID is 128.54.177 and the Host ID is 97. When using the CIDR format, the network mask is appended to the IP address. Thus the IP address and subnet mask shown above would be represented as 128.54.177.97 /24.

NOTE

The binary representation of a Network Mask must be a single continuous block 1's followed by a contiguous block of zeroes. When entering the Network Mask in dotted decimal notation, you must ensure that this requirement is maintained. For example, a network mask of 255.247.0.0 is not valid because the binary equivalent (11111111111101110000000000000000) violates this rule.

The Network Mask must allow at least two bits of host address. In addition, a network mask which causes the derived host ID to be 0 or a broadcast address (all Host ID bits set to 1) should not be used.

Using the Subnet Mask

For Class A, B, and C IP addresses, the IP Host uses the Subnet Mask to determine where to send an IP message. After deriving the Network ID and Host ID portion of the IP Address using the Subnet Mask, the IP Host compares the Network ID of the destination IP Address with the Network ID of the Host IP Address. If the Network IDs are the same, the message is sent to another Host on the local network. If the Network IDs are different, the message is sent to an IP Gateway, for routing to another network, if possible.

When you are configuring the IP Address of devices that must communicate on a local network, you must ensure that:

- The Subnet Mask of all devices is the same.
- The Network ID of all hosts is the same.
- The Host ID of each host is different.

If you are using Subnet Masks that are aligned with the IP Address octets, this can easily be done by examining the dotted decimal values. The octets of the IP Address where the corresponding octet of the Subnet Mask is 255 belong to the Network ID and the octets of the IP Address where the corresponding octet of the Subnet Mask is 0 belong to the Host ID.

For example, where the IP Address is 127.18.40.3 with a Subnet Mask of 255.255.0.0, the Network ID is 127.18 and the Host ID is 40.3.

IP Address	127	18	40	3
Subnet Mask	255	255	0	0
Network ID	127	18		
Host ID			40	3

However, if you are using a Subnet Mask that does not align with the octet boundaries, this is more difficult. You will need to perform a bitwise “and” calculation to arrive at the Network address. See the following illustration.

Assuming an IP Address of 127.18.40.3 and a Subnet Mask of 255.255.240.0, the following table illustrates the bitwise “and” operation. In essence, wherever the Subnet Mask bit is one, the corresponding IP Address bit is part of the Network ID.

Item	Dotted Decimal	Binary Equivalent			
		1 st Octet	2 nd Octet	3 rd Octet	4 th Octet
IP Address	127.18.40.3	01111111	00010010	00101000	00000011
Subnet Mask	255.255.240.0	11111111	11111111	11110000	00000000
Derived Network Address	127.18.32.0	01111111	00010010	00100000	00000000

An easier way to determine this is to compare only non-aligned Subnet Mask octet with the corresponding octet of the IP Address. For example, since the Subnet Mask of the first two octets is 255.255, the first two octets of the Network ID are the same as the dotted decimal values (127.18) of the IP Address. However, since the third octet of the subnet mask is not 255 or 0, you must perform a bitwise “and” calculation using the third octet of the IP Address and Subnet Mask.

This can be accomplished by using the Windows calculator Programmer view. Using this example, you would enter the value of the third octet (40), click on the “and” button, enter the Subnet Mask (240), and then click on the “=” button. The result, in this case, is 32. Thus, the Network Address is 127.18.32.0.

CIDR Notation

CIDR notation (Classless Inter-Domain Routing) is an alternate method of representing a subnet mask. It is simply a count of the number of network bits (bits that are set to 1) in the subnet mask. It provides a more concise way to represent the subnet mask. The CIDR number is typically preceded by a slash “/” and follows the IP address. For example, an IP address of 131.10.55.70 with a subnet mask of 255.0.0.0 (which has 8 network bits) would be represented as 131.10.55.70 /8. The following table can be used to convert between subnet mask and CIDR.

CIDR	Dotted Decimal		CIDR	Dotted Decimal
/1	128.0.0.0		/17	255.255.128.0
/2	192.0.0.0		/18	255.255.192.0
/3	224.0.0.0		/19	255.255.224.0
/4	240.0.0.0		/20	255.255.240.0
/5	248.0.0.0		/21	255.255.248.0
/6	252.0.0.0		/22	255.255.252.0
/7	254.0.0.0		/23	255.255.254.0
/8	255.0.0.0		/24	255.255.255.0
/9	255.128.0.0		/25	255.255.255.128
/10	255.192.0.0		/26	255.255.255.192
/11	255.224.0.0		/27	255.255.255.224
/12	255.240.0.0		/28	255.255.255.240
/13	255.248.0.0		/29	255.255.255.248
/14	255.252.0.0		/30	255.255.255.252
/15	255.254.0.0		/31	255.255.255.254
/16	255.255.0.0		/32	255.255.255.255

Selecting an IP Address

The JACP module typically requires a fixed IP Address. If you are connecting to an existing network, you should obtain an unused static IP Address and Subnet Mask from the network administrator.

If you are establishing your own IP Addresses, you should select IP Addresses from a block of ‘private’ addresses established by the Internet Assigned Numbers Authority (IANA). The private address blocks are:

- 10.0.0.0 through 10.255.255.255 (Class A)
- 172.16.0.0 through 172.31.255.255 (Class B)
- 192.168.0.0 through 192.168.255.255 (Class C)

These addresses will not be forwarded by the Internet backbone routers; therefore, you are free to use any address in this group as long as it does not conflict with the usage by your local organization.

Selecting a Multicast Address

The address range of 239.0.0.0 thru 239.255.255.255 has been designated as an administratively scoped Multicast Address space (RFC 2365). Addresses in this range are designated for use by private multicast domains. They do not conflict with other multicast address spaces that are explicitly assigned by Internet Assigned Numbers Authority (IANA). Within this range, addresses 239.255.0.0 thru 239.255.255.255 are designated for the IPV4 multicast local scope.

If you are choosing a Multicast Address for a new factory floor application, you should choose a Multicast Address in the IPV4 local scope range (239.255.0.0 thru 239.255.255.255) unless you have a specific reason to do otherwise. You should verify there is no conflict with other Multicast Addresses being used locally.

In case you are using the JACP module in an existing multicast application that uses a Multicast Address outside of the administratively scoped address space, the configuration program allows you to enter the complete range of assignable multicast addresses (224.0.0.1 thru 239.255.255.255).

For a current list of IANA assigned multicast addresses, see the IANA website:

www.iana.org/assignments/multicast-addresses/

APPENDIX C: ETHERNET PORT OPERATION

The following sections describe how the ports on the JACP module work and how Alternate IP subnets are applied.

Ethernet Port Operation

Ethernet (layer 2) is responsible for sending and receiving Ethernet frames, which contain the TCP/IP protocol and related data. Among other information, Ethernet frames contain a source address, which identifies the originator of the frame and a destination address, which indicates how the frame will be delivered. The source address contains the MAC (Media Access Control) address of the originator. The destination address may contain a **unicast** address (the MAC address of the intended recipient), a **multicast** address, or an address that indicates a **broadcast** address.

The Ethernet ports on the JACP module are connected to an Ethernet switch on the Janus circuit board. This switch is also connected to an internal Ethernet interface of the Janus microprocessor. By default, the external ports (PORTS 1 and 2) are isolated from each other. Frames entering one port are never forwarded to the other ports. This is important when connecting ports to different Ethernet networks. It prevents traffic (especially broadcast and multicast traffic) on one network from propagating to other networks. This is also important to prevent network loops, which can cause broadcast storms, when connecting multiple ports to the same Ethernet network, as you might do when designing redundant networks.

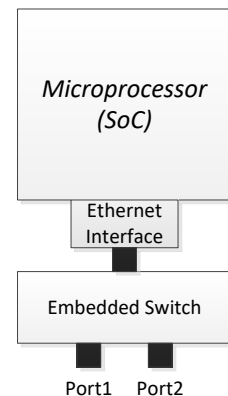

NOTE

You can enable forwarding between external ports for applications that require it. See [Section 4.2.3 Internal Ethernet Switch Configuration](#).

Frames entering the external ports are forwarded to the internal Ethernet interface if the Ethernet destination address is the same as the MAC address of the interface (Unicast) or when the destination address is a multicast or broadcast address. The switch does not forward frames that do not meet these criteria, preventing them from consuming microprocessor resources.

So, when a frame is sent *from* the internal Ethernet interface, how does the switch determine which port to forward it to? The answer to this is in the way Ethernet switches work. Ethernet switches learn the MAC address(es) of the device(s) connected to the ports. Once the port associated with a MAC address is known, the switch will forward a frame whose destination address matches this address to this port only.

NOTE

Broadcast and Multicast frames from the internal Ethernet interface will be forwarded to all frames. In the majority of cases, this traffic is insignificant. Broadcast frames are primarily transmitted when resolving IP addresses to MAC addresses. Once known, this information is cached. If you are sending substantial multicast traffic, network switches can be configured to limit Multicast forwarding (using IGMP Snooping). Alternatively, you may want to use only one network port.

Alternate IP Subnets

TCP/IP is responsible for functions such as routing IP packets among local area networks, establishing connections between devices (IP Hosts), and associating IP addresses with Ethernet MAC addresses. As noted above, on Ethernet networks, the TCP/IP protocol is contained as data in Ethernet frames.

An IP Host, such as the JACP module, can communicate directly with other IP Hosts on the same Ethernet Local Area Network only if they belong to the same IP subnet (see APPENDIX B: IP ADDRESS INFORMATION). Otherwise IP packets transmitted by the device are sent to an IP gateway, which attempts to route them to another network.

Typically, a single set of IP address parameters (IP address and subnet mask) are associated with a device's Ethernet interface. As a result, the device is limited to communicating directly with devices on a single IP subnet.

However, the JACP module allows you to associate up to two sets of IP parameters with its Ethernet Interface, enabling the module to communicate directly with devices on two different IP subnets, if desired.

This capability is especially useful when connecting the module to multiple Local Area Networks. See the example below. For simplicity, separate Ethernet switches for each network are illustrated. This topology can also be accomplished with one switch using VLAN (Virtual Local Area Network) technology.

Example

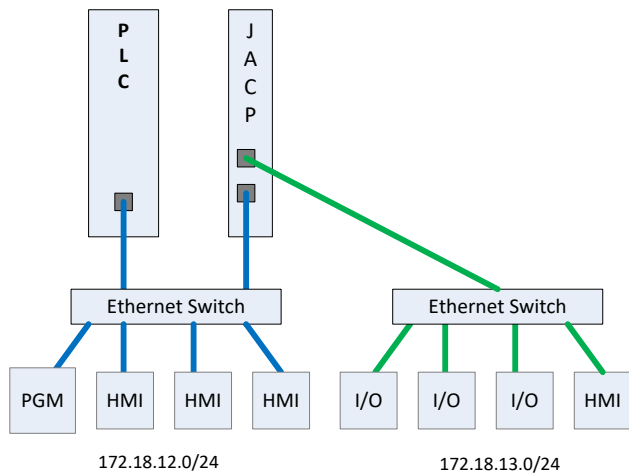

Port A is connected to a plant “data” network, used for programming and data access (HMI and SCADA workstations). Devices on this network are members of the IP subnet 172.18.12.0/24 (172.18.12.1, 172.18.12.2, etc.).

Port B is connected to an “I/O” network, used to communicate with Ethernet I/O. Devices on this network are members of the IP subnet 172.18.13.0/24 (172.18.13.1, 172.18.13.2, etc.).

The JACP module is configured to be a member of both IP subnets.

- Primary Subnet IP Address = 172.18.12.10 with Subnet Mask = 255.255.255.0.
- Alternate Subnet 1 IP Address = 172.18.13.10 with Subnet Mask =255.255.255.0.

Consequently, the JACP module is able to communicate directly with devices on either subnet. A CAMP Server application would be able to communicate with devices on the “data” network subnet and an Open Modbus Client would be able to communicate with I/O devices on the “I/O” network.

NOTE

*IP subnets are not directly associated with an Ethernet Port.
As explained earlier, the Ethernet switch is responsible for delivering frames containing the IP Protocol to the correct device via the corresponding port. It is acceptable (although unusual) for devices on different IP subnets to exist on the same Ethernet Local Area Network.
Also, IP subnets are not associated with an application. The embedded TCP/IP software (TCP/IP stack) routes data to an application based on the IP port number.*

APPENDIX D: Serial Port Wiring

RS232 Wiring

RS232 is the original single-ended serial interface (usually implemented as RS423 using 5V signals in modern devices) used for short-length connections in low-noise environments.

The following diagram shows the pin-out for wiring connections when RS232 is specified as the 'Interface' in the serial port parameter setup:

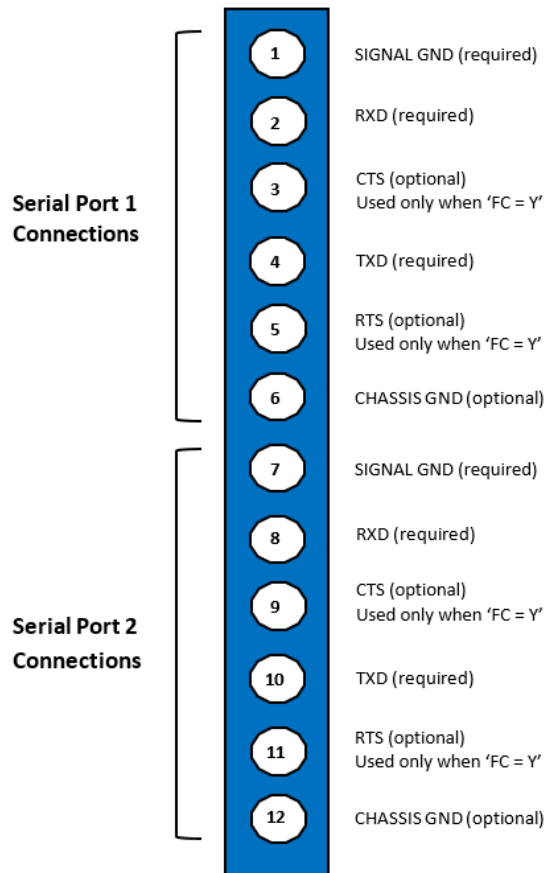

NOTES:

SIGNAL GND (Pin 1 or Pin 7) connects to Male DB9 connector SIGNAL GND (usually Pin 5).

RXD (Pin 2 or Pin 8) connects to Male DB9 connector (usually Pin 2).

TXD (Pin 4 or Pin 10) connects to Male DB9 connector (usually Pin 3).

When Hardware Flow Control is specified:

CTS (Pin 3 or Pin 9) connects to Male DB9 connector RTS (usually Pin 7).

RTS (Pin 5 or Pin 11) connects to Male DB9 connector CTS (usually Pin 8).

RS422 Wiring

RS422 is a 4-wire differential-signal serial interface that can be used in a multi-drop network. RS422 works over longer distances and has superior noise-immunity compared to RS232.

The following diagram shows the pin-out for wiring connections when RS422 is specified as the 'Interface' in the serial port parameter setup:

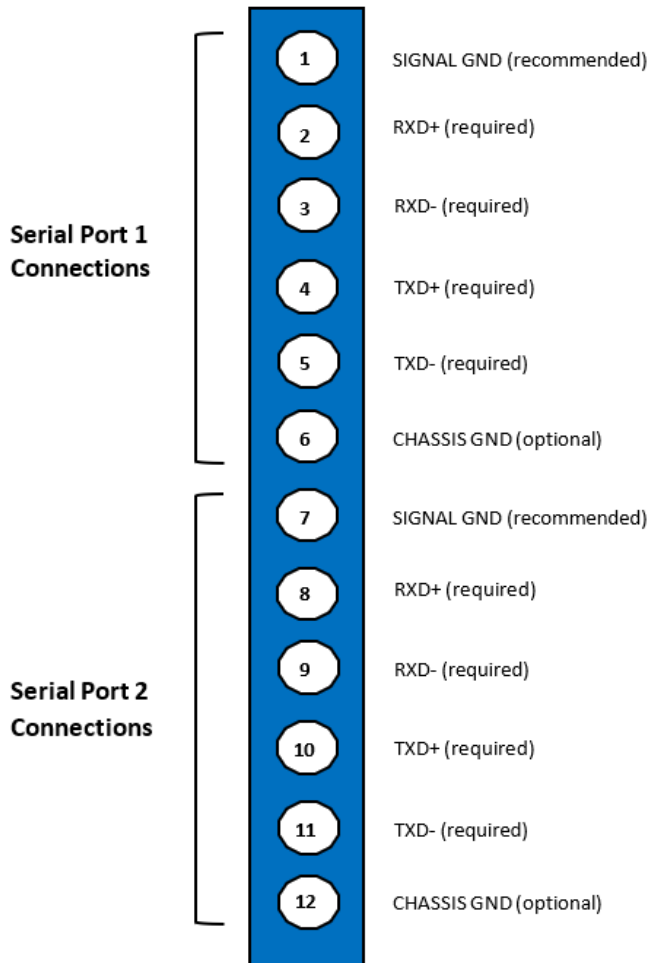

NOTES:

SIGNAL GND (Pin 1 or Pin 7) connects to Male DB9 connector (usually Pin 5).

TXD+/RXD+ (Pin 4 or Pin 10) connects to Male DB9 connector TXD+ (usually Pin 1).

TXD-/RXD- (Pin 5 or Pin 11) connects to Male DB9 connector TXD- (usually Pin 2).

RS485 Wiring

RS485 is a 2-wire differential-signal serial interface that can be used in a multi-drop network. RS485 has the same properties as RS422 with the advantage of requiring less expensive signal wiring.

The following diagram shows the pin-out for wiring connections when RS485 is specified as the 'Interface' in the serial port parameter setup:

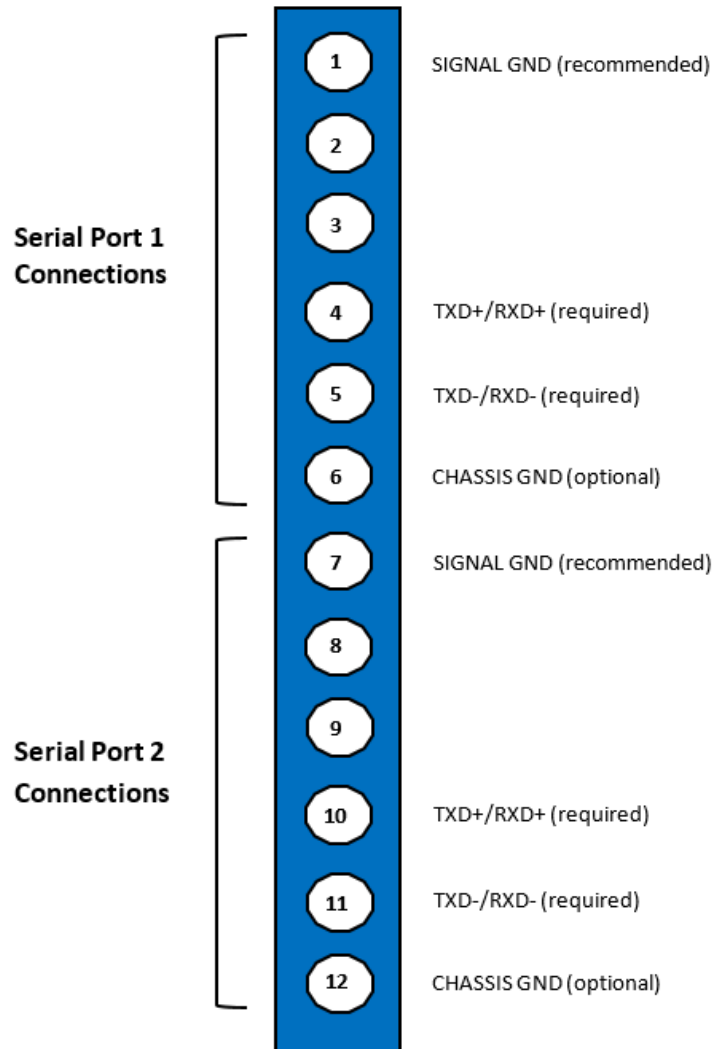

NOTES:

SIGNAL GND (Pin 1 or Pin 7) connects to Male DB9 connector (usually Pin 5).

TXD+/RXD+ (Pin 4 or Pin 10) connects to Male DB9 connector TXD+ (usually Pin 1).

TXD-/RXD- (Pin 5 or Pin 11) connects to Male DB9 connector TXD- (usually Pin 2).

APPENDIX E: PRODUCT SPECIFICATIONS

Environmental Specifications

Operating Temperature	0 to 60 C (32 to 140 F)
Storage Temperature	-40 to 70C (-40 to 158 F)
Relative Humidity	5% to 95% non-condensing
Pollution Degree	2, IEC 664, 664A
Vibration	
Sinusoidal	IEC 68-2-6 Test Fc 0.15 peak to peak, 10 – 57 Hz 1.0g. 57 – 150 Hz
Random	IEC 68-2-34 or NAVMAT p-9492 Test Fdc with 0.04 g ² /Hz, 80 – 350 Hz and 3db/Octave roll off, 80 -20 Hz and 350 – 2000Hz at 10 min/Axis
Impact Shock	IEC 68-2-27, Test Ea. Half Sine 15g, 11ms
Isolation, Inputs to Module	1500 VRMS except where specified
Corrosion Protection	All parts of corrosion resistant material or plated/painted as corrosion protection
Electric Noise Immunity	
Conducted Noise	IEC 801 Part 4 Level 3 MIL-STD-461B, Part 4:CS01, CS02, CS06 IEC 255-4, Appendix C IEC 4517/79 Com(78) 766 Final, Part 4 IEC 472, 2.5 KV
Radiated Noise	IEC 801 Part 3, Level 3 MIL-STD-461B, Part 4 RS01, RS02
Electrostatic Discharge	IEC 801. Part 2, Level 4 (15kV)

Agency Approvals (pending)

Pending

- UL, ULC
- FM (Class 1, DIV 2 - Hazardous Location) or equivalent
- CE Low Voltage Directive (73/23/EEC) and Electro-magnetic Compatibility Directive (89336/EEC)

Functional Specifications

2500P-JACP Janus Application Coprocessor	
Built-in display for IP address and errors	yes
Ethernet	
Number of IP/Subnet Configurations	2
Number of connections	64
User Memory	
Code (Programs + Fieldbus)	3MB
Data	4MB
Web Server	yes
Web Visualization (variables)	unlimited
Enhanced On-line change	yes
Communication Protocols	
Binding (peer-peer)	yes
CAMP Server	yes
Camp Client	yes
Modbus UDP/TCP Client	choose 2*
Modbus UDP/TCP Server	yes
Ethernet/IP Scanner & Flex I/O	choose 2*
Ethernet/IP Adapter	yes
Ethernet/IP Tag Server	yes
Ethernet/IP Tag Client	choose 2*
Ethernet/IP Explicit Message Server	yes
MQTT Client (communicates with broker)	yes
OPC-UA Server	yes
Profinet Controller & Device	future
Host PLC Interfaces	
CTI Enhanced Data Cache (1 Host PLC Connections / 6144 of variables)	choose 1*
CTI Block Transfer (Backplane data transfer) (1 Host PLC Connection / 4096 Variables)	choose 1*
Serial Communications	
Electrical Interfaces (2 ports)	RS232 / RS422 / RS485
Modbus-RTU Master/Slave	yes
General ASCII	yes

NOTES

Choose 1* Project may include one Host PLC interface: CTI Enhanced Data Cache or CTI Block Transfer

Choose 2** Project may include two of these protocols: Open Modbus Client, Ethernet/IP Scanner, Ethernet/IP Tag Client, Ethernet/IP Explicit Message Client

ETHERNET CONNECTION LIMIT

The 2500P-JACP permits a maximum of 64 Ethernet connections. This is the TOTAL of all Client protocol connections that are configured, plus whatever external devices connect to Server protocols.

For example, suppose an application has:

- 5 Modbus clients configured
- 4 Modbus devices which connect to the Modbus Server
- 16 Ethernet/IP scanner devices configured
- 2 devices which connect to the Ethernet/IP Tag Server
- 8 CAMP Client connections configured
- 4 devices which connect to CAMP Server
- 4 devices which connect to OPC-UA Server

This application has used $(5+4+16+2+8+4+4)$ or 43 out of the possible 64 connections.

LIMITED PRODUCT WARRANTY

Warranty. Control Technology Inc. ("CTI") warrants that this CTI Industrial Product (the "Product") shall be free from defects in material and workmanship for a period of one (1) year from the date of purchase from CTI or from an authorized CTI Industrial Distributor, as the case may be. Repaired or replacement CTI products provided under this warranty are similarly warranted for a period of 6 months from the date of shipment to the customer or the remainder of the original warranty term, whichever is longer. This Product and any repaired or replacement products will be manufactured from new and/or serviceable used parts which are equal to new in the Product. This warranty is limited to the initial purchaser of the Product from CTI or from an authorized CTI Industrial Distributor and may not be transferred or assigned.

2. Remedies. Remedies under this warranty shall be limited, at CTI's option, to the replacement or repair of this Product, or the parts thereof, only after shipment by the customer at the customer's expense to a designated CTI service location along with proof of purchase date and an associated serial number. Repair parts and replacement products furnished under this warranty will be on an exchange basis and all exchanged parts or products become the property of CTI. Should any product or part returned to CTI hereunder be found by CTI to be without defect, CTI will return such product or part to the customer. The foregoing will be the exclusive remedies for any breach of warranty or breach of contract arising therefrom.

3. General. This warranty is only available if (a) the customer provides CTI with written notice of a warranty claim within the warranty period set forth above in Section 1 and (b) CTI's examination of the Product or the parts thereof discloses that any alleged defect has not been caused by a failure to provide a suitable environment as specified in the CTI Standard Environmental Specification and applicable Product specifications, or damage caused by accident, disaster, acts of God, neglect, abuse, misuse, transportation, alterations, attachments, accessories, supplies, non-CTI parts, non-CTI repairs or activities, or to any damage whose proximate cause was utilities or utility-like services, or faulty installation or maintenance done by someone other than CTI.

4. Product Improvement. CTI reserves the right to make changes to the Product in order to improve reliability, function or design in the pursuit of providing the best possible products.

5. Exclusive Warranty. THE WARRANTIES SET FORTH HEREIN ARE CUSTOMER'S EXCLUSIVE WARRANTIES. CTI HEREBY DISCLAIMS ALL OTHER WARRANTIES, EXPRESS OR IMPLIED. WITHOUT LIMITING THE FOREGOING, CTI SPECIFICALLY DISCLAIMS THE IMPLIED WARRANTIES OF MERCHANTABILITY, FITNESS FOR A PARTICULAR PURPOSE, NON-INFRINGEMENT, COURSE OF DEALING, AND USAGE OF TRADE.

6. Disclaimer and Limitation of Liability. TO THE FULLEST EXTENT PERMITTED BY APPLICABLE LAW, CTI WILL NOT BE LIABLE FOR ANY BUSINESS INTERRUPTION OR LOSS OF PROFIT, REVENUE, MATERIALS, ANTICIPATED SAVINGS, DATA, CONTRACT, GOODWILL OR THE LIKE (WHETHER DIRECT OR INDIRECT IN NATURE) OR FOR ANY OTHER FORM OF INCIDENTAL, INDIRECT OR CONSEQUENTIAL DAMAGES OF ANY KIND. CTI'S MAXIMUM CUMULATIVE LIABILITY RELATIVE TO ALL OTHER CLAIMS AND LIABILITIES, INCLUDING OBLIGATIONS UNDER ANY INDEMNITY, WHETHER OR NOT INSURED, WILL NOT EXCEED THE COST OF THE PRODUCT(S) GIVING RISE TO THE CLAIM OR LIABILITY. CTI DISCLAIMS ALL LIABILITY RELATIVE TO GRATUITOUS INFORMATION OR ASSISTANCE PROVIDED BY, BUT NOT REQUIRED OF CTI HEREUNDER. ANY ACTION AGAINST CTI MUST BE BROUGHT WITHIN EIGHTEEN (18) MONTHS

AFTER THE CAUSE OF ACTION ACCRUES. THESE DISCLAIMERS AND LIMITATIONS OF LIABILITY WILL APPLY REGARDLESS OF ANY OTHER CONTRARY PROVISION HEREOF AND REGARDLESS OF THE FORM OF ACTION, WHETHER IN CONTRACT, TORT (INCLUDING NEGLIGENCE AND STRICT LIABILITY) OR OTHERWISE, AND FURTHER WILL EXTEND TO THE BENEFIT OF CTI'S VENDORS, APPOINTED DISTRIBUTORS AND OTHER AUTHORIZED RESELLERS AS THIRD-PARTY BENEFICIARIES. EACH PROVISION HEREOF WHICH PROVIDES FOR A LIMITATION OF LIABILITY, DISCLAIMER OF WARRANTY OR CONDITION OR EXCLUSION OF DAMAGES IS SEVERABLE AND INDEPENDENT OF ANY OTHER PROVISION AND IS TO BE ENFORCED AS SUCH.

7. Adequate Remedy. The customer is limited to the remedies specified herein and shall have no others for a nonconformity in the Product. The customer agrees that these remedies provide the customer with a minimum adequate remedy and are its exclusive remedies, whether based on contract, warranty, tort (including negligence), strict liability, indemnity, or any other legal theory, and whether arising out of warranties, representations, instructions, installations, or non-conformities from any cause. The customer further acknowledges that the purchase price of the Product reflects these warranty terms and remedies.

8. Force Majeure. CTI will not be liable for any loss, damage or delay arising out of its failure (or that of its subcontractors) to perform hereunder due to causes beyond its reasonable control, including without limitation, acts of God, acts or omissions of the customer, acts of civil or military authority, fires, strikes, floods, epidemics, quarantine restrictions, war, riots, acts of terrorism, delays in transportation, or transportation embargoes. In the event of such delay, CTI's performance date(s) will be extended for such length of time as may be reasonably necessary to compensate for the delay.

9. Governing Law. The laws of the State of Tennessee shall govern the validity, interpretation and enforcement of this warranty, without regard to its conflicts of law principles. The application of the United Nations Convention on Contracts for the International Sale of Goods shall be excluded.

REPAIR POLICY

In the event that the Product should fail during or after the warranty period, a Return Material Authorization (RMA) number can be requested orally or in writing from CTI main offices. Whether this equipment is in or out of warranty, a Purchase Order number provided to CTI when requesting the RMA number will aid in expediting the repair process. The RMA number that is issued and your Purchase Order number should be referenced on the returning equipment's shipping documentation. Additionally, if the product is under warranty, proof of purchase date and serial number must accompany the returned equipment. The current repair and/or exchange rates can be obtained by contacting CTI's main office at 1-800-537-8398 or go to www.controltechnology.com/support/repairs/.

When returning any module to CTI, follow proper static control precautions. Keep the module away from polyethylene products, polystyrene products and all other static producing materials. Packing the module in its original conductive bag is the preferred way to control static problems during shipment. Failure to observe static control precautions may void the warranty.